

# 785 Magnetic Latching Square Base Relay/DPDT, 16 Amp Rating



High strength magnetic latch helps contacts hold during vibration.



Single and Dual (DC only) coil available.

16 Amp switching capabilities

Standard .1875 blade style socket mounting.

## General Specifications

(UL 508)

785XBX

Contact Characteristics		Units	Standard
Number and type of Contacts			DPDT
Contact materials			Silver Alloy
Thermal (Carrying) Current		A	16
Maximum Switching Voltage		V	300
Switching Current @ Voltage		~ Resistive	16A @ 277V 50/60Hz
		~ Resistive	16A @ 120V 50/60Hz
		⋮ Resistive	16A @ 28V
		HP	1/3 @ 120 VAC
		HP	1/2 @ 240 VAC
		Pilot Duty	B300
Minimum Switching Requirement		mA	100 @ 5 VDC (.5W)
Coil Characteristics			
Voltage Range		~ V	6...240, 50/60 Hz
		⋮ V	6...125
Operating Range		~	85% to 110%
		⋮	80% to 110%
Average consumption	% of Nominal	~ VA	3
		⋮ W	1.4
Drop-out voltage threshold		~	15%
		⋮	10%
Performance Characteristics			
Electrical Life (UL508)	Operations @ Rated Current	(Resistive)	100,000
Mechanical Life	Unpowered		5,000,000
Operating time (response time)		ms	20
Dielectric strength	Between coil and contact	~ V(rms)	1500
	Between poles	~ V(rms)	1500
	Between contacts	~ V(rms)	1500
Environment			
Product certifications	Standard version		UL, CSA, CE
Ambient air temperature around the device	Storage	°C	-40...+85
	Operation	°C	-40...+55
Vibration resistance	Operational	g-n	3, 10 - 55 Hz
Shock resistance		g-n	10
Degree of protection			IP 40
Weight		grams	87

## WIRING DIAGRAMS

NEMA IEC

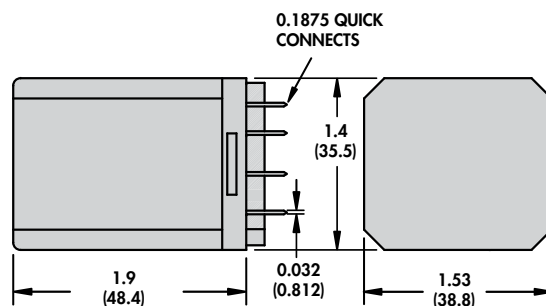
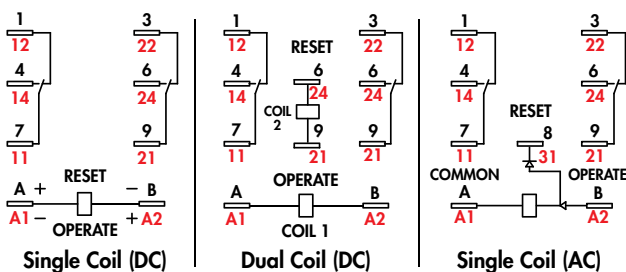

SECTION 7



The 785 Magnetic Latching relay, with an Industry Standard square base, operates by using a pulsed input. A permanent magnet maintains the last position until a redirected second pulse moves the contacts back to the original state.

**Standard Part Numbers**

**BOLD-FACED PART NUMBERS ARE NORMALLY STOCKED**

Nominal Voltage	Coil Resistance	Part Number
AC Operated (Single Coil)		
6 VAC 50/60 HZ	32 Ohms	785XBXC-6A
12 VAC 50/60 HZ	120 Ohms	785XBXC-12A
24 VAC 50/60 HZ	470 Ohms	785XBXC-24A
120 VAC 50/60 HZ	10,000 Ohms	<b>785XBXC-120A</b>
240 VAC 50/60 HZ	40,000 Ohms	785XBXC-240A
DC Operated (Dual Coil)		
6 VDC	22/22 Ohms	785XBXCD-6D
12 VDC	88/88 Ohms	785XBXCD-12D
24 VDC	350/350 Ohms	<b>785XBXCD-24D</b>
48 VDC	1,400/1,400 Ohms	785XBXCD-48D
110/125 VDC	9,000/9,000 Ohms	785XBXCD-110D
DC Operated (Single Coil)		
12 VDC	120 Ohms	785XBXC-12D
24 VDC	470 Ohms	785XBXC-24D
110/125 VDC	10,000 Ohms	785XBXC-125D

**Part Number Builder**

785	XBX	C	-	240A
Series	Contact Configuration	Coil Options	Coil Voltage	
785	DPDT = XBX	Single Coil = C Double Coil = CD	VAC = 6 - 240A VDC = 6 - 125D	

Other mating sockets see Section 2: 70-788EL11-1, 70-124-1, 70-124-2, 70-178-1, 70-178-2

