

G4 Digital DC Input Modules

Features

- 4000 volts transient optical isolation
- Built-in LED status indicator
- Small footprint design, reducing mounting space by approximately 50 percent
- Built-in filtering for transient suppression and noise rejection
- Operating temperature: -30 °C to 70 °C
- UL recognized, CSA certified, CE approved
- Passes NEMA Showering Arc Test (ICS 2-230)
- Meets IEEE Surge Withstand Specification (IEEE-472)

Description

Opto 22's G4 DC input modules are used to detect on/off DC voltage levels. Each module provides up to 4000 volts (transient) of optical isolation between field inputs and the logic output of the circuit.

All DC input modules except the G4IDC5K and G4IDC5D are designed with filtering on the input and a hysteresis amplifier, providing high noise rejection and transient-free, "clean" switching. The G4IDC5K is a fast-switching module used to detect signals produced by photoelectric switches and TTL devices. The low-cost G4IDC5D is used for data acquisition.

The G4IDC5MA is a special module featuring a manual-on/manual-off/automatic switch, ideal for diagnostic testing of control applications.

The G4IDC5-SW and G4IDC5-SWNC modules supply power to an external dry contact switch and sense switch closure (SW) or opening (SWNC).

Typical applications for DC input modules include sensing the presence or absence of voltage and sensing contact closure from sources such as proximity switches, limit switches, selector switches, push buttons, photoelectric switches, and TTL-compatible devices.

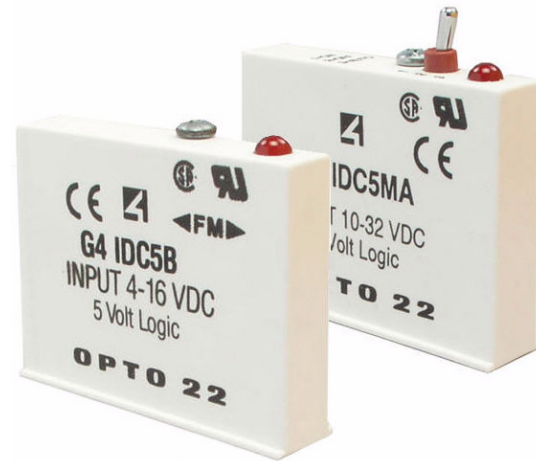

Opto 22 G4 digital input modules include the G4IDC5B high-speed module and the G4IDC5MA module with manual-on/manual-off/automatic switch for diagnostic testing.

Part Numbers

Part	Description
G4IDC5	G4 DC Input 10–32 VDC, 5 VDC Logic
G4IDC5B	G4 DC Input 4–16 VDC, 5 VDC Logic High Speed
G4IDC5D	G4 DC Input 2.5–28 VDC, 5 VDC Logic
G4IDC5G	G4 DC Input 35–60 VDC, 5 VDC Logic
G4IDC5K	G4 DC Input 2.5–16 VDC, 5 VDC Logic Very High Speed
G4IDC5MA	G4 DC Input 10–32 VDC, 5 VDC Logic With Manual/Auto Switch
G4IDC5-SW	G4 Switch Status Input, Self-powered, Normally Open
G4IDC5-SWNC	G4 Switch Status Input, Self-powered, Normally Closed
G4IDC15	G4 DC Input 10–32 VDC, 15 VDC Logic
G4IDC24	G4 DC Input 10–32 VDC, 24 VDC Logic

G4 Digital DC Input Modules

Specifications

	Units	G4IDC5	G4IDC5B	G4IDC5D	G4IDC5G
Input voltage range	VDC VAC	10–32 12–32	4–16 4–16	2.5–28 —	35–60 35–60
Key feature		—	Higher speed	High speed	—
Input current at maximum line	mA	25	45	30	6
Isolation, input-to-output (transient):					
1 ms	V	4000	4000	4000	4000
1 minute	V	1500	1500	1500	1500
Turn-on time	ms	5	0.05	1	10
Turn-off time	ms	5	0.1	1.5	10
Input allowed for off-state	mA, V	1, 3	0.7, 1	0.2, 1	0.7, 7
Nominal output supply voltage	VDC	5	5	5	5
Output supply voltage range	VDC	4.5–6	4.5–6	4.5–6	4.5–6
Output supply current at nominal logic voltage	mA	12	12	12	12
Input resistance (R1 in schematic)	ohms	1.5 K	300	900	10 K
Control resistance (Rc in schematic)	ohms	220	220	470	220
Output voltage drop	V @ 50 mA	0.4	0.4	0.4	0.4
Output current (sinking)	mA	50	50	50	50
Output leakage with no input	microamps @ 30 VDC	100	100	10	100
Transistor	V breakdown	30	30	30	30
Temperature:					
Operating	°C	-30 to +70	-30 to +70	-30 to +70	-30 to +70
Storage	°C	-30 to +85	-30 to +85	-30 to +85	-30 to +85

G4IDC5-SW and G4IDC5-SWNC modules

See [page 4](#) for specifications and other information for the G4IDC5-SW and G4IDC5-SWNC self-powered modules. Schematic drawings for these modules appear on page 5.

G4 Digital DC Input Modules

Dimensions

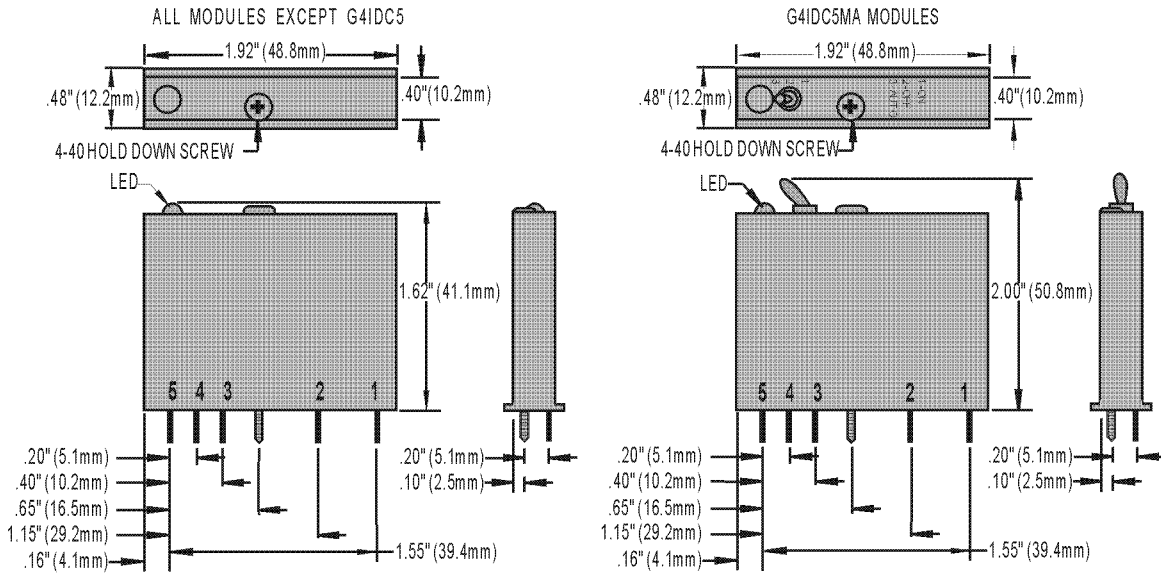

Schematics

