

# Features

- Efficiency up to 95%, Non isolated,
- Very low profile 4mm
- Wide input range.(4.75V ~ 36V)
- Short circuit protection, Thermal shutdown
- Non standard outputs available as specials
- Low ripple and noise
- EMC Compliant
- See InnoLine Application Notes for use as an inverter (alternative to LM79xx Linear)

## Description

The ROF-78xx-0.5SMD high efficiency switching regulators are ideally suited to replace SMD linear regulators. The efficiency of up to 95% means that very little energy is wasted as heat so full power operation over the full industrial ambient temperature range of -40°C to +85°C is possible. Low ripple and noise figures and short circuit , overload and over-temperature protection round off the specifications of this versatile converter series. This ROF-78xx-0.5SMD is compliant to EN 55022 CISPR 22 Class B (Emissions) with a simple external filter, EN 61000-6-1 and EN 61000-6-2 Crit A (Radiated Susceptibility), EN 61000-4-2 Crit B (Electrostatic Discharge 4kV).

## Selection Guide

Part Number SIP3	Input Range (V)	Output Voltage (V)	Output Current (A)	Efficiency	
				Min. Vin (%)	Max. Vin (%)
ROF-781.8-0.5SMD	4.75 – 34	1.8	0.5	82	68
ROF-783.3-0.5SMD	4.75 – 34	3.3	0.5	92	79
ROF-785.0-0.5SMD	6.5 – 36	5.0	0.5	95	86

## Standard Application Circuit

\* Input capacitor required if  $V_{in} > 26VDC$  (3.3 $\mu F$ ) or if the supply is a battery or other low impedance source (4.7 $\mu F$ ~10 $\mu F$ )

Capacitor should be electrolytic or MLCC with 1R resistor in series

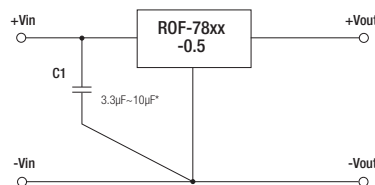

## Optional Protection Circuit

Add a blocking diode to Vout if current can flow backwards into the output, as this can damage the converter when it is powered down.

The diode can either be fitted across the device if the source is low impedance or fitted in series with the output (recommended).

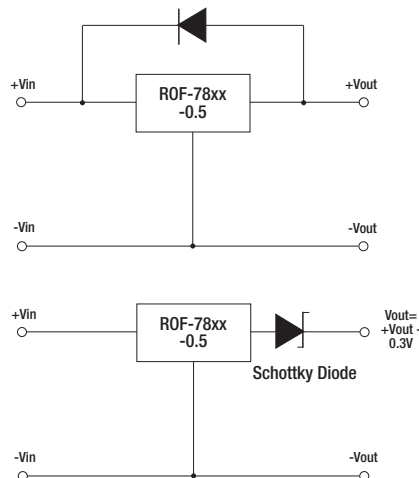

# INNOLINE

DC/DC-Converter



## 0.5 AMP SMD Single Output



**EN-55022 Compliant**  
**EN-61000-6-1 Compliant**  
**EN-61000-6-2 Compliant**  
**EN-61000-4-2 Compliant**

# ROF-78xx -0.5SMD

## Derating-Graph (Ambient Temperature)

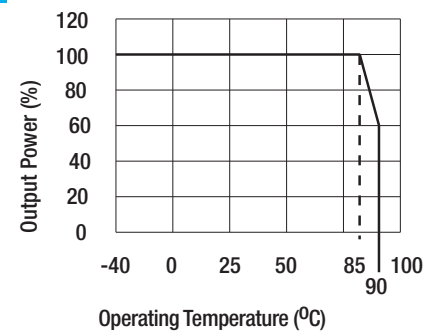

**Specifications** ( typical at 25°C, 10% minimum load, unless otherwise specified )

Characteristics	Conditions	Min.	Typ.	Max.
Input Voltage Range	1.8V, 3.3V	4.75	12/24V	36V abs. max.
	5.0V	6.5	12/24V	36V abs. max.
Output Voltage Range (for customized parts)	All Series	1.75		5.25V
Output Current (see note)		0*		500mA
Output Current Limit				1500mA
Short Circuit Input Current (Typical Vin)				60mA
Internal Power Dissipation	All series			0.5W
Short Circuit Protection			Continuous, automatic recovery	
Output Voltage Accuracy (At 100% Load)			±2	±3%
Line Voltage Regulation (Vin - min. to max. at full load)	All series		0.2	0.4%
Load Regulation (10 to 100% full load)	All series		0.4	0.6%
Note: Operation under no load will not damage these devices, however they may not meet all specifications. A minimum load of 6mA is recommended				
Dynamic Load Stability	100% <-> 50% load		±75mV	
	100% <-> 10% load			±100mV
Ripple & Noise (without Output Capacitor)	All series			50mVp-p
Max capacitance Load (with blocking diodes and 1 sec start up time)				6800µF
Switching Frequency			500kHz	
Quiescent Current	Vin = min. to max. at 0% load		5	7mA
Shutdown Input Current	All series		1.3	4µA
Remote On/Off Shutdown Threshold Voltage	All series	0.9	1.25	1.55
Start-up Time	All series		3.2	5.0msec.
Operating Temperature Range		-40°C		+90°C
Storage Temperature Range		-55°C		+125°C
Thermal Shutdown	Internal IC junction			+182°C
Conducted Emissions	EN55022			Class B with Filter
Radiated Emissions	EN55022			Class B with Filter
Radiated Susceptibility	EN61000-6-1			Class A
	EN61000-6-2			Class A
ESD	EN61000-4-2			Class B
Package Weight			0.9g	
Packing Quantity				50pcs per Tray
				*tape and reel packaging available upon request
Tray Dimension				281.2mm X 157.60mm
MTBF (+25°C)	Detailed Information see Application Notes chapter "MTBF"	using MIL-HDBK 217F		19048 x 10 <sup>3</sup> hours

**ROF-78xx-0.5SMD**

**Class B Conducted/ Radiated Emissions Filter Suggestion**

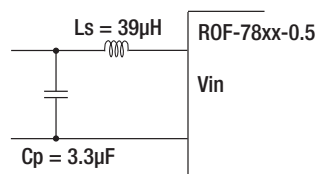

Characteristics

**Efficiency**

**Ripple**

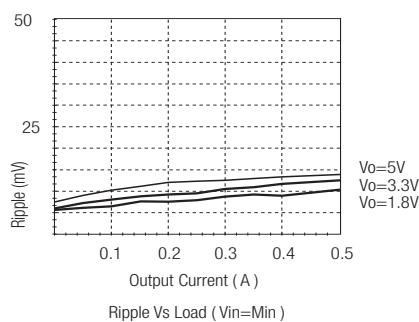
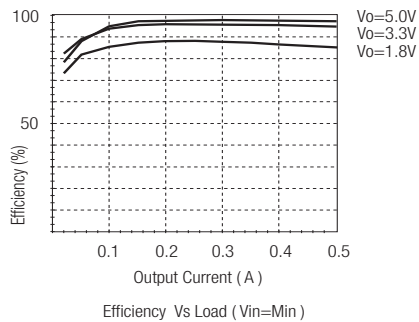
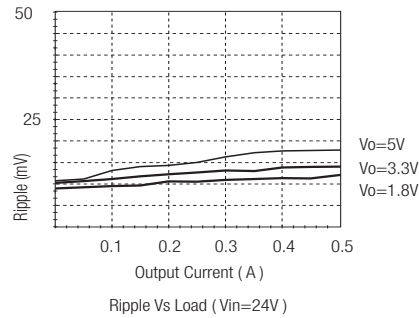
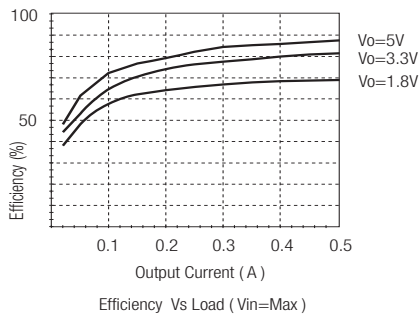
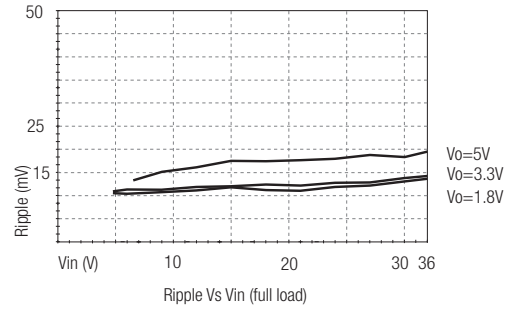
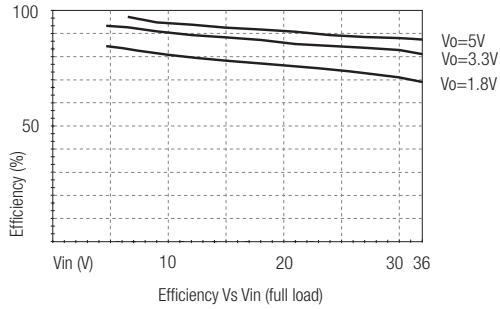

**ROF-78xx  
-0.55MD**

## Application Examples

High efficiency, isolated, dual unregulated outputs

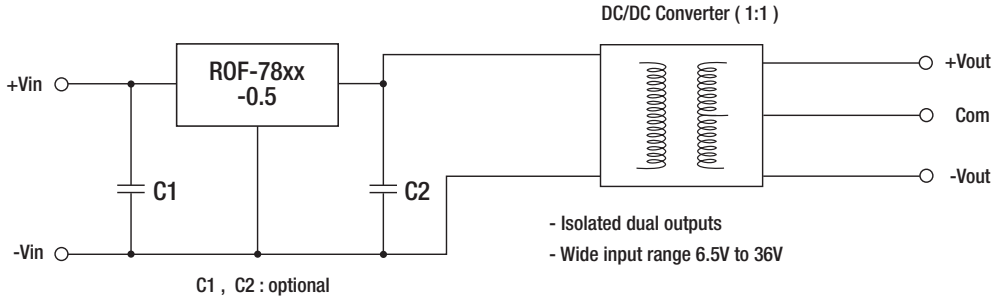

Isolated (up to 6KV), wide Input range regulated output

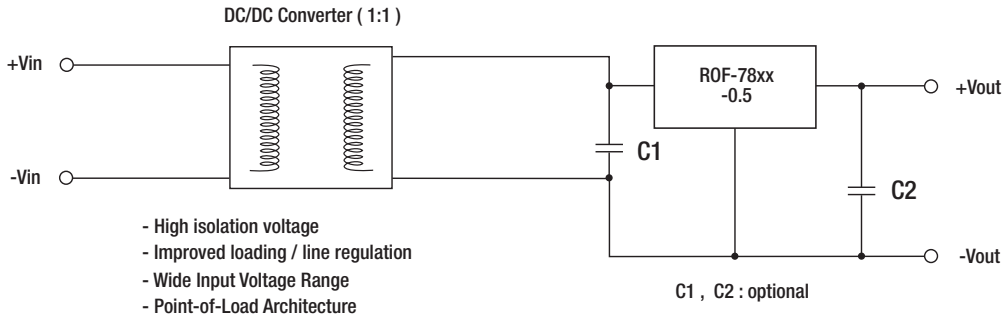

**ROF-78xx-0.5SMD**

## Package Style and Pinning (mm)



ROF-78xx-0.5SMD  
Surface Mount Package

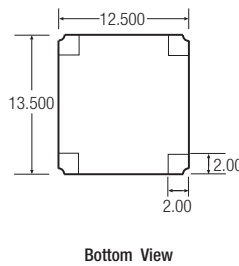
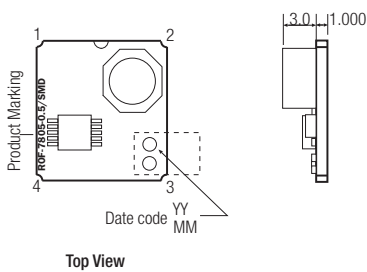

### Recommended Footprint Details

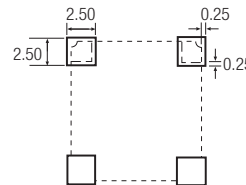

### Pin Connections

Pin #	Connection
1	+Vin
2	GND
3	+Vout
4	EN

x.x +0.5mm/ -0.0mm  
xx.xx ±0.2mm  
xx.xxx ±0.15mm