



- Industry standard footprint
- MTBF >1.4 million hours (Bellcore 332)
- Input voltage to ETS300-132-2
- Adjustable output voltage
- No minimum load required
- Separate case ground pin
- 2:1 input range for battery powered applications
- Undervoltage lockout (UVLO)
- UL, VDE and CSA safety approvals

The BXB150 Series are high power density DC/DC converters packaged in the industry standard footprint (2.40 x 2.28 x 0.50 inches) to give designers optimum choices when specifying for both new and replacement designs. Suitable for a wide range of applications in nearly any industry, the BXB150 was particularly designed with communication and distributed power applications in mind. Using Bellcore 332, the MTBF is greater than 1,400,000 hours. Aluminum baseplate technology with four threaded M3 inserts makes heatsink attachment and optimum thermal management easy. The BXB150 series is approved to IEC950 by UL, CSA and VDE.

[ 2 YEAR WARRANTY ]



**SPECIFICATION** All specifications are typical at nominal input, full load at 25°C unless otherwise stated

OUTPUT SPECIFICATIONS		
Voltage adjustability		60% to 110%
Set point accuracy		±1.0%
Line regulation	Low line to high line	±0.05%
Load regulation	Full load to min. load	±0.10%
Minimum load		0%
Overshoot	At turn-on and turn-off	None
Undershoot		None
Ripple and noise (5Hz to 20MHz) (See Note 1)	3.3V and 5V	75mV pk-pk, 20mV rms
	12V and 15V	100mV pk-pk, 30mV rms
Temperature coefficient		±0.01%/°C
Transient response (See Note 2)		±2.0% max. deviation 170µs recovery to within ±1.0%
Remote sense		0.5VDC transmission line drop compensation
INPUT SPECIFICATIONS		
Input voltage range	24Vin nominal	18 to 36VDC
	48Vin nominal	36 to 75VDC
Input current	No load	130mA max.
	Remote OFF	20mA max.
Input current (max.) (See Note 4)	24Vin	9.0A max. @ Io max. and Vin = 0 to 75V
	48Vin	6.5A max. @ Io max. and Vin = 0 to 75V
Input reflected ripple	(See Note 6)	5mA pk-pk
Active low remote ON/OFF Logic compatibility ON OFF		(See Note 7) Open collector ref to -input 1.2VDC max. Open circuit

INPUT SPECIFICATIONS CONTINUED		
Undervoltage lockout	24Vin: power up	17V
	24Vin: power down	16.3V
	48Vin: power up	34V
	48Vin: power down	32.5V
Start-up time (See Note 8)	Power up	20ms
	Remote ON/OFF	20ms
EMC CHARACTERISTICS		
Conducted emissions (See Note 3)	Bellcore 1089	Level A
	FCC part 15	Level A
	EN55022, CISPR22	Level A
GENERAL SPECIFICATIONS		
Efficiency		See table
Isolation voltage	Input/case	1500VDC
	Input/output	1500VDC
	Output/case	1500VDC
Switching frequency	Fixed	500kHz typ.
Approvals and standards (See Note 5)		VDE0805, EN60950, IEC950 UL1950, CSA C22.2 No. 950
Case material		Aluminum baseplate with plastic case
Material flammability		UL94V-0
Weight		110g (3.88oz)
MTBF	Bellcore 332	1,400,000 hours
	MIL-HDBK-217F @ 40°C, 100% FL	580,000 hours min.
ENVIRONMENTAL SPECIFICATIONS		
Thermal performance	Operating case temp.	-40°C to +100°C
	Non-operating	-55°C to +125°C
Altitude	Operating	10,000 feet max.
	Non-operating	40,000 feet max.
Vibration	5Hz to 500Hz	2.4G rms (approx.)

# 100 to 150 Watt Wide input DC/DC converters

OUTPUT POWER (MAX.)	INPUT VOLTAGE	OVP	OUTPUT VOLTAGE	OUTPUT CURRENT (MIN.)	OUTPUT CURRENT (MAX.)	EFFICIENCY (TYP.)	REGULATION		MODEL NUMBER (7)
							LINE	LOAD	
100W	18-36VDC	4.3VDC	3.3V	0A	30A	77%	±0.05%	±0.1%	BXB150-24S3V3FLT
100W	36-75VDC	4.3VDC	3.3V	0A	30A	79%	±0.05%	±0.1%	BXB150-48S3V3FLT
150W	36-75VDC	6.5VDC	5V	0A	30A	84%	±0.05%	±0.1%	BXB150-48S05FLT
150W	36-75VDC	14.5VDC	12V	0A	12.5A	84%	±0.05%	±0.1%	BXB150-48S12FLT
150W	36-75VDC	17.5VDC	15V	0A	10A	88%	±0.05%	±0.1%	BXB150-48S15FLT

## Notes

- Measured with 10µF tantalum capacitor and 1µF ceramic capacitor across output.
- di/dt = 0.1A/1µs, Vin = 48VDC, Tc = 25°C, load change = 0.5 Io max. to 0.75 Io max. and 0.75 Io max. to 0.5 Io max.
- Units should be characterised within systems. External components required.
- Input fusing is recommended based on surge current and maximum input current.
- This product is only for inclusion by professional installers within other equipment and must not be operated as a stand alone product.
- Simulated source impedance of 12µH. 12µH inductor in series with +Vin.
- Active high remote on/off option is available (standard product is active low), designate with the suffix 'FHT' e.g. **BXB150-48S05FHT**. Consult factory for further details and options.
- Start-up into resistive load.

## PROTECTION

Short circuit protection	Continuous, automatic recovery
Oversvoltage protection	Non-latching
Undersvoltage protection	Non-latching
Thermal protection	110°C baseplate, automatic recovery

## TELECOM SPECIFICATIONS

Central office interface A	ETS300-132-2
----------------------------	--------------

## EXTERNAL OUTPUT TRIMMING

Output can be externally trimmed by using the method shown below.

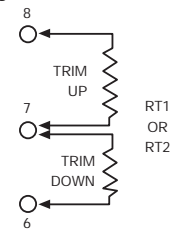

## International Safety Standard Approvals

	VDE0805/EN60950/IEC950 File No. 10401-3336-1095
	UL1950 File No. E136005
	CSA C22.2 No. 950 File No. LR41062C

PIN CONNECTIONS	
PIN NUMBER	FUNCTION
1	+ Vin
2	Remote ON/OFF
3	Case
4	- Vin
5	- Vout
6	- Sense
7	Trim
8	+ Sense
9	+ Vout

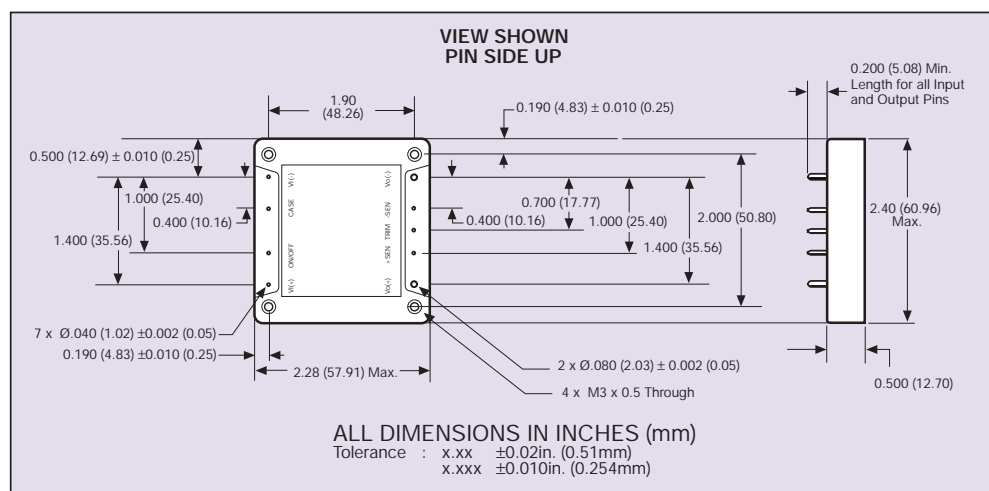

Data Sheet © Artesyn Technologies® 2000

The information and specifications contained in this data sheet are believed to be correct at time of publication. However, Artesyn Technologies accepts no responsibility for consequences arising from printing errors or inaccuracies. Specifications are subject to change without notice. No rights under any patent accompany the sale of any such product(s) or information contained herein.