



XCXL004DNC



Actual product appearance may vary.

Pressure Sensors: Measurement Type: Differential, Gage, Vacuum Gage; Signal Conditioning: Unamplified; Pressure Range: ± 4.0 inches of water; Port Style: Barbed: Commercial Grade

Features

- Pressure Ranges from 4 in H₂O, 10 in H₂O 1 psi through 150 psi
- Calibrated offset to \pm mV
- Calibrated Full Scale Span to ± 1.0 % FS over Compensated Temperature Range
- Temperature Compensated over 0 °C to +70 °C
- Gage, Differential, and Absolute Pressure
- Burst Pressure 3X Rated
- Ratiometric mV Output

Potential Applications

- Medical Applications
- Applications Requiring Small Size
- Applications Requiring Vacuum, Positive Pressure or Both

Description

The XCXL, XCX Series integrates silicon micromachined sensing technology, temperature compensation, and calibration in an improved performance industry standard package. A unique stress isolating design protects against torque induced errors typically found in competitive products. Additional stability and long term accuracy improvements are gained through simplified compensation techniques, which eliminate temperature dependent thermal compensation. This series is available in a commercial (XCX-DNC) performance level. This performance level provides the calibration accuracy of offset thermal compensation, and linearity providing added flexibility to meet critical performance budgets. The XCA and XCR Series provide amplified output as well as integrated compensation.

Product Specifications	
Measurement Type	Differential, Vacuum Gage, Gage
Signal Conditioning	Unamplified
Pressure Range	± 4.0 in H ₂ O
Maximum Overpressure	5.0 psi
Supply Voltage	3.0 Vdc min., 12.0 Vdc typ., 16.0 Vdc max.
Compensated	Yes
Output Calibration	Yes
Termination	PCB
Port Style	Barbed
Package Style	Honeywell DI-XCX

Typical Sensitivity	10 mV/in H ₂ O
Full Scale Span	40 mV typ.
Null Offset	0 mV typ.
Null Shift over Temperature	± 1 mV
Span Shift Over Temperature	± 2% span
Linearity, Hysteresis Error	± 0.5 % Span Typ.; ± 1 % Span Max.
Repeatability	0.1% span typ.
Input Resistance	15.0 kOhm
Shock	10 g
Weight	7.6 g [0.27 oz]
Operating Temperature Range	-25 °C to 85 °C [-13 °F to 185 °F]
Compensated Temperature Range	0 °C to 50 °C [32 °F to 122 °F]
Storage Temperature Range	-40 °C to 125 °C [-40 °F to 257 °F]
Media Compatibility	Port 1: Dry gases only. Media must be compatible with epoxy-based adhesive. Port 2: Wetted materials. Media must be compatible with nylon housing, epoxy adhesive and silicon.
UNSPSC Code	411121
UNSPSC Commodity	411121 Transducers
Availability	Global
Series Name	XCXL

REV#	DOCUMENT	CHANGED BY	CHECK
1	201333	TRF 22SEP00	SAV
2	203123	GJM 01JUN01	SAV

SERIES
UNAMPLIFIED
COMPENSATED AND
CALIBRATED (MVI)

ACCURACY GRADE
C - COMMERCIAL (1.0%)
H - HIGH GRADE (0.50%)

PACKAGE TYPE
N - PLASTIC

PRESSURE REFERENCE
D - DIFFERENTIAL

PRESSURE RANGE Δ
004, 010 IN H₂O
003, 01, 05, 15, 30,
60, 100, 150, 240 PSID

NOTES
 Δ ALL PARAMETERS ARE MEASURED AT 12 VDC EXCITATION. APPLY POSITIVE PRESSURE TO PORT 2 FOR POSITIVE GOING OUTPUT
 Δ SHIFT IS RELATIVE TO 25°C
 Δ LINEARITY IS DETERMINED USING BEST STRAIGHT LINE FIT THROUGH ZERO.
 1/2 FULL SCALE, AND FULL SCALE; HYSTERESIS IS MECHANICAL ONLY
 4 - SPAN IS THE ALGEBRAIC DIFFERENCE BETWEEN OFFSET VOLTAGE AND THE VOLTAGE AT FULL SCALE PRESSURE
 Δ PRESSURE RANGE INDICATES THE FULL SCALE PRESSURE OF THE SENSOR

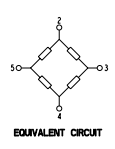

PIN OUT	
1	N/C
2	+V EXCITATION
3	+ OUTPUT SIGNAL
4	-V EXCITATION
5	- OUTPUT SIGNAL
6	N/C

- C - GRADE LISTINGS**
- KCXL010DC
 - KCXL010DC
 - KCXL030DC
 - KCXL010DC
 - KCXL050DC
 - KCX150DC
 - KCX300DC
 - KCX600DC
 - KCX1000DC
 - KCX1500DC
 - KCX2400DC
- H - GRADE LISTINGS**
- KCXL0040NH
 - KCXL0100NH
 - KCXL030NH
 - KCX010NH
 - KCX050NH
 - KCX150NH
 - KCX300NH
 - KCX600NH
 - KCX1000NH
 - KCX1500NH
 - KCX2400NH

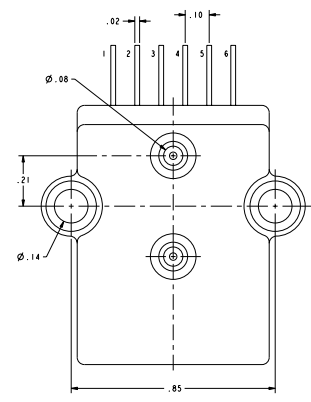
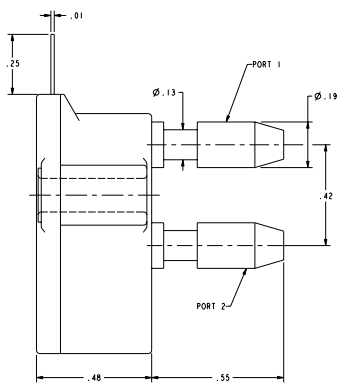
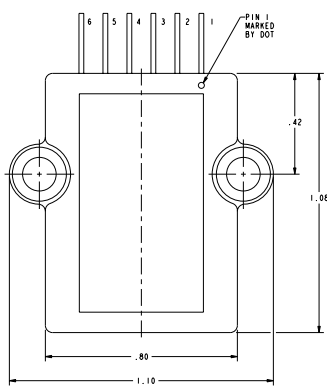

PARAMETERS Δ	PRESSURE RANGE	C GRADE			H GRADE			PROOF PRESSURE		
		MV	NOM	MAX	UNITS	MV	NOM		MAX	UNITS
OFFSET VOLTAGE (0 IN H ₂ O DIFF)	ALL	-1.0	0.0	1.0	mV	-0.3	0.0	0.3	mV	5 PSID
SPAN (P2-P1)	4 IN H ₂ O	38.0	40.0	42.0	mV	19.8	20.0	20.2	mV	5 PSID
	10 IN H ₂ O	19.0	20.0	21.0	mV	19.8	20.0	20.2	mV	5 PSID
	0.3 PSID	19.0	20.0	21.0	mV	19.8	20.0	20.2	mV	5 PSID
	1 PSID	17.0	18.0	19.0	mV	17.8	18.0	18.2	mV	5 PSID
	5 PSID	57.0	60.0	63.0	mV	59.0	60.0	61.0	mV	15 PSID
	15 PSID	85.0	90.0	95.0	mV	89.0	90.0	91.0	mV	45 PSID
	30 PSID	85.0	90.0	95.0	mV	89.0	90.0	91.0	mV	90 PSID
	60 PSID	85.0	90.0	95.0	mV	89.0	90.0	91.0	mV	180 PSID
	100 PSID	85.0	90.0	95.0	mV	89.0	90.0	91.0	mV	240 PSID
	150 PSID	85.0	90.0	95.0	mV	89.0	90.0	91.0	mV	300 PSID
240 PSID	85.0	100.0	105.0	mV	89.0	100.0	101.0	mV	300 PSID	
COMBINED LINEARITY AND HYSTERESIS Δ	ALL	---	0.5	1.0	%SPAN	---	0.3	0.5	%SPAN	
INPUT RESISTANCE	ALL	---	15	---	K Ω	---	15	---	K Ω	
TEMPERATURE ERROR ON OFFSET (0° TO 50°C) Δ	4 IN H ₂ O	---	---	1.0	mV	---	---	0.5	mV	
TEMPERATURE ERROR ON OFFSET (0° TO 70°C) Δ	ALL EXCEPT 4 IN H ₂ O	---	---	1.0	mV	---	---	0.5	mV	
TEMPERATURE ERROR ON SPAN (0° TO 50°C) Δ	4 IN H ₂ O	---	---	2.0	%SPAN	---	---	1.0	%SPAN	
TEMPERATURE ERROR ON SPAN (0° TO 70°C) Δ	ALL EXCEPT 4 IN H ₂ O	---	---	2.0	%SPAN	---	---	1.0	%SPAN	
REPEATABILITY	ALL	---	0.1	---	%SPAN	---	0.1	---	%SPAN	

EXCITATION VOLTAGE	ALL	3	12	16	VDC
COMPENSATED TEMPERATURE RANGE	ALL	0	25	70	°C
STORAGE TEMPERATURE RANGE	ALL	-40	---	125	°C
RELATIVE HUMIDITY (NON-CONDENSING)	ALL	0	---	95	%RH
SHOCK (DURATION 11 msec ANY AXIS)	ALL	---	---	10	g
COMMON MODE PRESSURE	ALL	---	---	50	PSID

MEDIA CAPABILITY, WETTED MATERIALS
(APPLY CLEAN DRY AIR ONLY)

PRESSURE: SILICON DIAPHRAGM, GLASS FILLED NYLON, AND ALUMINA
PORT 2: CERAMIC. PORT NOT USED FOR ABSOLUTE DEVICES

PRESSURE FRONTSIDE OF SILICON DIAPHRAGM, SILICONE GEL
PORT 1: PASSIVATION, GLASS FILLED NYLON, ALUMINA.

UNLESS OTHERWISE SPECIFIED TOLERANCES ARE:	DECIMAL	FRACTION	DRIVEN	TRF	22SEP00	Moorewell Sealing and Control
NO PLACE	.040	.01	CHECK	SAV	22SEP00	
PER PLACE	.010	.005	00.15	THIS DRAWING COVERS A PROPRIETARY LITER AND IS THE PROPERTY OF MOOREWELL		PRESSURE SENSOR
THREE PLACE	.005	0	SENTING AND CONTROL. THIS DRAWING IS NOT TO BE COPIED OR USED WITHOUT THE WRITING MATERIAL-COMMERCIAL STANDARD			
THIRD ANGLE PROJECTION	PERMISSION OF MOOREWELL.	SIZE	DWG TYPE	DRIVING NAME	XCX DIF SERIES CHART 1	REV 2
DIMENSIONS ARE TO BE MET BEFORE PROTECTIVE COATINGS ARE APPLIED	SCALE	5:1	WEIGHT	SHEET	1	OF 1