

Guard Lock Safety-door Switch D4NL

Safety Interlock
Switches

D4NL

Lead-free, Environment-friendly Design

- Contains no harmful substances, such as lead, cadmium or hexavalent chromium, reducing the burden on the environment.
- Models with 4-contact and 5-contact built-in Switches are available.
- Key holding force of 1,300 N minimum.
- Can be used for either standard loads or microloads.
- Lineup includes models with a conduit size of M20.
- IP67 degree of protection.



NEW

Model Number Structure

Model Number Legend

Switch

D4NL-□□□□-□□□□
1 2 3 4 5 6 7

1. Conduit Size

- 1: Pg13.5
- 2: G1/2
- 4: M20

2. Built-in Switch (with Door Open/Closed Detection Switch and Lock Monitor Switch Contacts)

- A: 1NC/1NO slow-action contacts plus 1NC/1NO slow-action contacts
- B: 1NC/1NO slow-action contacts plus 2NC slow-action contacts
- C: 2NC slow-action contacts plus 1NC/1NO slow-action contacts
- D: 2NC slow-action contacts plus 2NC slow-action contacts
- E: 2NC/1NO slow-action contacts plus 1NC/1NO slow-action contacts
- F: 2NC/1NO slow-action contacts plus 2NC slow-action contacts
- G: 3NC slow-action contacts plus 1NC/1NO slow-action contacts
- H: 3NC slow-action contacts plus 2NC slow-action contacts

3. Head Mounting Direction and Material

- F: Four mounting directions possible (Front-side mounting at time of delivery)/plastic
- D: Four mounting directions possible (Front-side mounting at time of delivery)/metal

4. Door Lock and Release

- A: Mechanical lock/24-VDC solenoid release
- B: Mechanical lock/110-VAC solenoid release
- C: Mechanical lock/230-VAC solenoid release
- G: 24-VDC solenoid lock/mechanical release
- H: 110-VAC solenoid lock/mechanical release
- J: 230-VAC solenoid lock/mechanical release

5. Indicator

- B: 10 to 115 VAC/VDC (orange LED indicator)

6. Release Key Type

- Blank: Standard
- 4: Special release key

7. Release Key Position

- Blank: Bottom
- S: Front

8. NPT, 1/2"-14 NPT Conduit

- Adapter included
- (Applicable to M20 Conduit models only)

Note: Models with M20 conduits are also available with an M20 to 1/2-14NPT Adaptor.

Operation Key

D4DS-K□

1

1. Operation Key Type

- 1: Horizontal mounting
- 2: Vertical mounting
- 3: Adjustable mounting (horizontal)
- 5: Adjustable mounting (horizontal/vertical)



OMRON SCIENTIFIC TECHNOLOGIES, INC.
USA Tel. 1/888/510-4357 Canada Tel. 1/866/986-6766



For the Latest Information
On the Internet: www.sti.com or www.omron.ca

OMRON

Ordering Information

■ List of Models

Switches (Operation Keys are sold separately.)

Head material	Release key position	Release key type	Solenoid voltage/ indicator	Lock and release types	Contact configuration (door open/closed detection switch and lock monitor switch contacts) (slow-action) Approved direct opening NC contact	Conduit opening	Model
Plastic (See note.)	Bottom	Standard	Solenoid: 24 VDC Orange LED: 10 to 115 VAC/VDC	Mechanical lock Solenoid release	1NC/1NO+1NC/1NO	Pg13.5	D4NL-1AFA-B
						G1/2	D4NL-2AFA-B
						M20	D4NL-4AFA-B
					1NC/1NO+2NC	Pg13.5	D4NL-1BFA-B
						G1/2	D4NL-2BFA-B
						M20	D4NL-4BFA-B
					2NC+1NC/1NO	Pg13.5	D4NL-1CFA-B
						G1/2	D4NL-2CFA-B
						M20	D4NL-4CFA-B
					2NC+2NC	Pg13.5	D4NL-1DFA-B
						G1/2	D4NL-2DFA-B
						M20	D4NL-4DFA-B
					2NC/1NO+1NC/1NO	Pg13.5	D4NL-1EFA-B
						G1/2	D4NL-2EFA-B
						M20	D4NL-4EFA-B
					2NC/1NO+2NC	Pg13.5	D4NL-1FFA-B
						G1/2	D4NL-2FFA-B
						M20	D4NL-4FFA-B
					3NC+1NC/1NO	Pg13.5	D4NL-1GFA-B
						G1/2	D4NL-2GFA-B
						M20	D4NL-4GFA-B
					3NC+2NC	Pg13.5	D4NL-1HFA-B
						G1/2	D4NL-2HFA-B
						M20	D4NL-4HFA-B
				Solenoid lock Mechanical release	1NC/1NO+1NC/1NO	Pg13.5	D4NL-1AFG-B
						G1/2	D4NL-2AFG-B
						M20	D4NL-4AFG-B
					1NC/1NO+2NC	Pg13.5	D4NL-1BFG-B
						G1/2	D4NL-2BFG-B
						M20	D4NL-4BFG-B
					2NC+1NC/1NO	Pg13.5	D4NL-1CFG-B
						G1/2	D4NL-2CFG-B
						M20	D4NL-4CFG-B
					2NC+2NC	Pg13.5	D4NL-1DFG-B
						G1/2	D4NL-2DFG-B
						M20	D4NL-4DFG-B
					2NC/1NO+1NC/1NO	Pg13.5	D4NL-1EFG-B
						G1/2	D4NL-2EFG-B
						M20	D4NL-4EFG-B
					2NC/1NO+2NC	Pg13.5	D4NL-1FFG-B
						G1/2	D4NL-2FFG-B
						M20	D4NL-4FFG-B
					3NC+1NC/1NO	Pg13.5	D4NL-1GFG-B
						G1/2	D4NL-2GFG-B
						M20	D4NL-4GFG-B
					3NC+2NC	Pg13.5	D4NL-1HFG-B
						G1/2	D4NL-2HFG-B
						M20	D4NL-4HFG-B

Note: Switches with metal heads can also be manufactured upon request. Ask your OMRON representative for details.



OMRON SCIENTIFIC TECHNOLOGIES, INC.
USA Tel. 1/888/510-4357 Canada Tel. 1/866/986-6766



For the Latest Information
On the Internet: www.sti.com or www.omron.ca

OMRON

Safety Interlock
Switches

D4NL





Safety Interlock Switches
D4NL

Head material	Release key position	Release key type	Solenoid voltage/indicator	Lock and release types	Contact configuration (door open/closed detection switch and lock monitor switch contacts) (slow-action) Approved direct opening NC contact	Conduit opening	Model
Plastic (See note.)	Bottom	Special release key	Solenoid: 24 VDC Orange LED: 10 to 115 VAC/VDC	Mechanical lock Solenoid release	1NC/1NO+1NC/1NO	Pg13.5	D4NL-1AFA-B4
						G1/2	D4NL-2AFA-B4
						M20	D4NL-4AFA-B4
					1NC/1NO+2NC	Pg13.5	D4NL-1BFA-B4
						G1/2	D4NL-2BFA-B4
						M20	D4NL-4BFA-B4
					2NC+1NC/1NO	Pg13.5	D4NL-1CFA-B4
						G1/2	D4NL-2CFA-B4
						M20	D4NL-4CFA-B4
					2NC+2NC	Pg13.5	D4NL-1DFA-B4
						G1/2	D4NL-2DFA-B4
						M20	D4NL-4DFA-B4
					2NC/1NO+1NC/1NO	Pg13.5	D4NL-1EFA-B4
						G1/2	D4NL-2EFA-B4
						M20	D4NL-4EFA-B4
					2NC/1NO+2NC	Pg13.5	D4NL-1FFA-B4
						G1/2	D4NL-2FFA-B4
						M20	D4NL-4FFA-B4
					3NC+1NC/1NO	Pg13.5	D4NL-1GFA-B4
						G1/2	D4NL-2GFA-B4
						M20	D4NL-4GFA-B4
					3NC+2NC	Pg13.5	D4NL-1HFA-B4
						G1/2	D4NL-2HFA-B4
						M20	D4NL-4HFA-B4
				Solenoid lock Mechanical release	1NC/1NO+1NC/1NO	Pg13.5	D4NL-1AFG-B4
						G1/2	D4NL-2AFG-B4
						M20	D4NL-4AFG-B4
					1NC/1NO+2NC	Pg13.5	D4NL-1BFG-B4
						G1/2	D4NL-2BFG-B4
						M20	D4NL-4BFG-B4
					2NC+1NC/1NO	Pg13.5	D4NL-1CFG-B4
						G1/2	D4NL-2CFG-B4
						M20	D4NL-4CFG-B4
					2NC+2NC	Pg13.5	D4NL-1DFG-B4
						G1/2	D4NL-2DFG-B4
						M20	D4NL-4DFG-B4
					2NC/1NO+1NC/1NO	Pg13.5	D4NL-1EFG-B4
						G1/2	D4NL-2EFG-B4
						M20	D4NL-4EFG-B4
					2NC/1NO+2NC	Pg13.5	D4NL-1FFG-B4
						G1/2	D4NL-2FFG-B4
						M20	D4NL-4FFG-B4
					3NC+1NC/1NO	Pg13.5	D4NL-1GFG-B4
						G1/2	D4NL-2GFG-B4
						M20	D4NL-4GFG-B4
					3NC+2NC	Pg13.5	D4NL-1HFG-B4
						G1/2	D4NL-2HFG-B4
						M20	D4NL-4HFG-B4

Note: Switches with metal heads can also be manufactured upon request. Ask your OMRON representative for details.

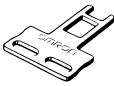

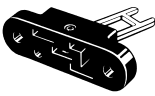
Operation Keys

Type	Model
Horizontal mounting 	D4DS-K1
Vertical mounting 	D4DS-K2
Adjustable mounting (Horizontal) 	D4DS-K3
Adjustable mounting (Horizontal/Vertical) 	D4DS-K5

Specifications

■ Standards and EC Directives

- Machinery Directive
- Low Voltage Directive
- EN1088
- EN60204-1
- GS-ET-19

■ Approved Standards

Agency	Standard	File No.
TÜV Product Service	EN60947-5-1 (approved direct opening)	(See note 1.)
UL (See note 2.)	UL508, CSA C22.2 No.14	E76675
CQC (CCC)	GB14048.5	2003010305064 267

- Note:** 1. Consult your OMRON representative for details.
2. Approval for CSA C22.2 No. 14 is authorized by the UL mark.
3. Ask your OMRON representative for information on approved models.

■ Approved Standard Ratings

TÜV (EN60947-5-1), CCC (GB14048.5)

Item	Utilization category	AC-15	DC-13
Rated operating current (I_n)		3 A	0.27 A
Rated operating voltage (U_n)		240 V	250 V

Note: Use a 10-A fuse type gI or gG that conforms to IEC60269 as a short-circuit protection device. This fuse is not built into the Switch.

UL/CSA (UL508, CSA C22.2 No. 14)

A300

Rated voltage	Carry current	Current		Volt-amperes	
		Make	Break	Make	Break
120 VAC	10 A	60 A	6 A	7,200 VA	720 VA
240 VAC		30 A	3 A		

Q300

Rated voltage	Carry current	Current		Volt-amperes	
		Make	Break	Make	Break
125 VDC	2.5 A	0.55 A	0.55 A	69 VA	69 VA
250 VDC		0.27 A	0.27 A		

Solenoid Coil Characteristics

Item	24 VDC	110 VAC	230 VAC
Rated operating voltage (100% ED)	24 VDC $\pm 10\%$	110 VAC $\pm 10\%$	230 VAC $\pm 10\%$
Current consumption	Approx. 200 mA	Approx. 50 mA	Approx. 30 mA
Insulation	Class F (130°C max.)		

Indicator Characteristics

Item	LED
Rated voltage	10 to 115 VAC/VDC
Current leakage	Approx. 1 mA
Color (LED)	Orange



■ Characteristics

Degree of protection (see note 3)		IP67 (EN60947-5-1) (This applies for the Switch only. The degree of protection for the key hole is IP00.)	
Durability (see note 4)	Mechanical	1,000,000 operations min.	
	Electrical	500,000 operations min. for a resistive load of 3 A at 250 VAC (see note 5)	
Operating speed		0.05 to 0.5 m/s	
Operating frequency		30 operations/minute max.	
Rated frequency		50/60 Hz	
Contact gap		2 x 2 mm min	
Direct opening force (see note 6)		60 N min. (EN60947-5-1)	
Direct opening travel (see note 6)		10 mm min. (EN60947-5-1)	
Holding force (see note 7)		1,300 N min.	
Insulation resistance		100 M Ω min. (at 500 VDC)	
Minimum applicable load (see note 8)		Resistive load of 1 mA at 5 VDC (N-level reference value)	
Rated insulation voltage (U _i)		300 V (EN60947-5-1)	
Rated open thermal current (I _{th})		10 A (EN60947-5-1)	
Impulse withstand voltage (EN60947-5-1)		Between terminals of the same polarity	2.5 kV
		Between terminals of different polarities	4 kV
		Between other terminals and uncharged metallic parts	6 kV
Conditional short-circuit current		100 A (EN60947-5-1)	
Pollution degree (operating environment)		3 (EN60947-5-1)	
Protection against electric shock		Class II (double insulation)	
Contact resistance		25 m Ω max. per contact (initial value)	
Vibration resistance	Malfunction	10 to 55 Hz, 0.75-mm single amplitude	
Shock resistance	Destruction	1,000 m/s ² min.	
	Malfunction	100 m/s ² min.	
Ambient temperature		Operating: -10°C to 55°C with no icing	
Ambient humidity		Operating: 95% max.	
Weight		Approx. 370 g (D4NL-IAFA-B)	

- Note:**
- The above values are initial values.
 - The Switch contacts can be used with either standard loads or microloads. Once the contacts have been used to switch a load, however, they cannot be used to switch smaller loads. The contact surfaces will become rough once they have been used and contact reliability for smaller loads may be reduced.
 - The degree of protection is tested using the method specified by the standard (EN60947-5-1). Confirm that sealing properties are sufficient for the operating conditions and environment beforehand. Although the switch box is protected from dust or water penetration, do not use the D4NL in places where foreign material may enter through the key hole on the head, otherwise Switch damage or malfunctioning may occur.
 - The durability is for an ambient temperature of 5°C to 35°C and an ambient humidity of 40% to 70%. For more details, consult your OMRON representative.
 - If the ambient temperature is greater than 35°C, do not pass the 3-A, 250-VAC load through more than 2 circuits.
 - These figures are minimum requirements for safe operation.
 - This figure is based on the GS-ET-19 evaluation method.
 - This value will vary with the switching frequency, environment, and reliability level. Confirm that correct operation is possible with the actual load beforehand.

Connections

■ Contact Form

Indicates conditions where the Key is inserted and the lock is applied. Terminals 12 and 41 are connected internally (as per GS-ET-19).

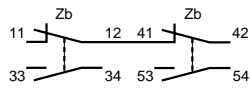
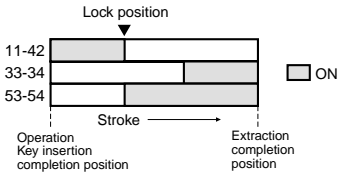
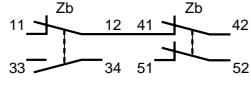
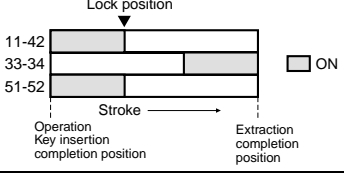
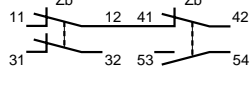
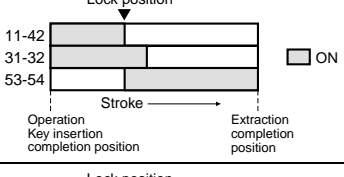
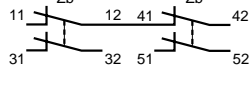
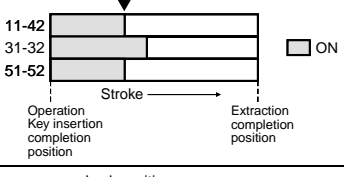
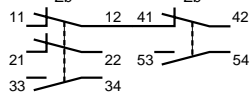
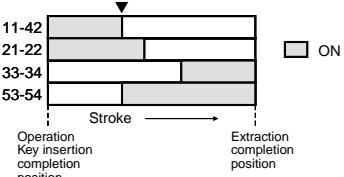
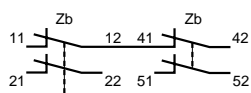
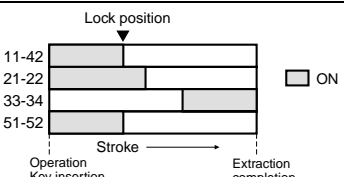
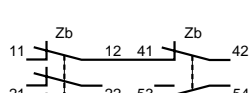
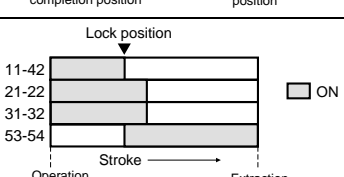
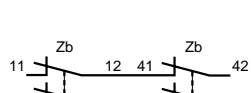
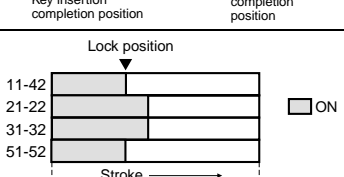
Model	Contact	Contact form	Operating pattern	Remarks
D4NL-□AF□-□	1NC/1NO + 1NC/1NO			Only NC contacts 11-12 have an approved direct opening mechanism. (⊖) The terminals 11-42, 33-34, and 53-54 can be used as unlike poles.
D4NL-□BF□-□	1NC/1NO + 2NC			Only NC contacts 11-12 have an approved direct opening mechanism. (⊖) The terminals 11-42, 33-34, and 51-52 can be used as unlike poles.
D4NL-□CF□-□	2NC + 1NC/1NO			Only NC contacts 11-12 and 31-32 have an approved direct opening mechanism. (⊖) The terminals 11-42, 31-32, and 53-54 can be used as unlike poles.
D4NL-□DF□-□	2NC + 2NC			Only NC contacts 11-12 and 31-32 have an approved direct opening mechanism. (⊖) The terminals 11-42, 31-32, and 51-52 can be used as unlike poles.
D4NL-□EF□-□	2NC/1NO + 1NC/1NO			Only NC contacts 11-12 and 21-22 have an approved direct opening mechanism. (⊖) The terminals 11-42, 21-22, 33-34, and 53-54 can be used as unlike poles.
D4NL-□FF□-□	2NC/1NO + 2NC			Only NC contacts 11-12 and 21-22 have an approved direct opening mechanism. (⊖) The terminals 11-42, 21-22, 33-34, and 51-52 can be used as unlike poles.
D4NL-□GF□-□	3NC + 1NC/1NO			Only NC contacts 11-12, 21-22, and 31-32 have an approved direct opening mechanism. (⊖) The terminals 11-42, 21-22, 31-32, and 53-54 can be used as unlike poles.
D4NL-□HF□-□	3NC + 2NC			Only NC contacts 11-12, 21-22, and 31-32 have an approved direct opening mechanism. (⊖) The terminals 11-42, 21-22, 31-32, and 51-52 can be used as unlike poles.

Indicator

Internal Circuit Diagram

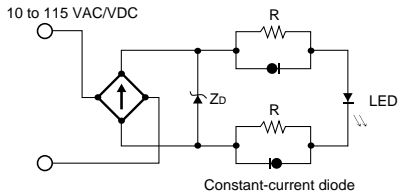

Circuit Connection Example

Examples for the D4NL-□F□□-B

- Terminals 12 and 41 are connected internally and so connect terminals 11 and 42 for safety-circuit input. (GS-ET-19).
- Connect terminals 21 and 22 and terminals 51 and 52 in series when using as safety-circuit input (redundancy circuit for terminals 11 and 12 and terminals 41 and 42 above). Connect the terminals individually when using as auxiliary-circuit input (e.g., terminals 21 and 22 for safety-door open/closed monitoring and terminals 51 and 52 for monitoring the lock status).
- In the connection example on the right, terminals 21 and 22 and terminals 51 and 52 are used as auxiliary-circuit input.

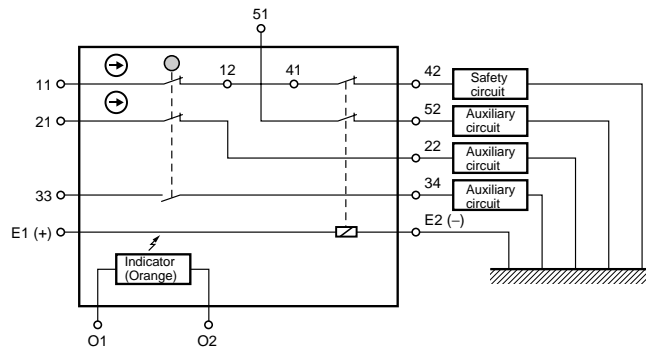

- Direct opening contacts used as safety-circuit input are indicated with the ⊖ mark. Terminals 11 and 12 and terminals 21 and 22 are direct opening contacts.
- Connect the indicators in parallel to the auxiliary circuits or terminals E1 and E2.
If an indicator is connected in parallel to a direct opening contact, when the indicator breaks, a short-circuit current will be generated, possibly resulting in an installation malfunction.
- Do not switch standard loads for more than 2 circuits at the same time. Otherwise, the level of insulation may decrease.
- The DC solenoid terminals have polarity. Confirm the polarity before wiring.

Operation Method

■ Operation Principles

<p>Mechanical lock models</p>			
<p>Solenoid lock models</p>			
		<p>When the Operation Key is inserted, it is locked by the lock spring. The door will stay locked even if there is a power interruption.</p>	<p>The solenoid is released only when the lock is turned ON.</p>
		<p>If the solenoid is OFF, the door will not be locked when the Operation Key is inserted. This means that the door can be opened and closed easily when replacing workpieces or parts.</p>	<p>The door is locked only when the solenoid is turned ON. This means that the door will be unlocked if there is a power interruption and so this model cannot be used in systems that would maintain a hazardous state (e.g., systems requiring toxic gases, high temperatures, or gears that would continue to turn due to inertia).</p>

Safety / Interlock Switches
D4NL

Nomenclature

■ Structure

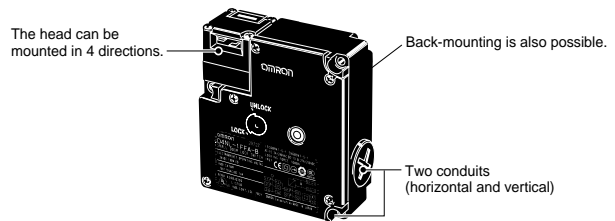
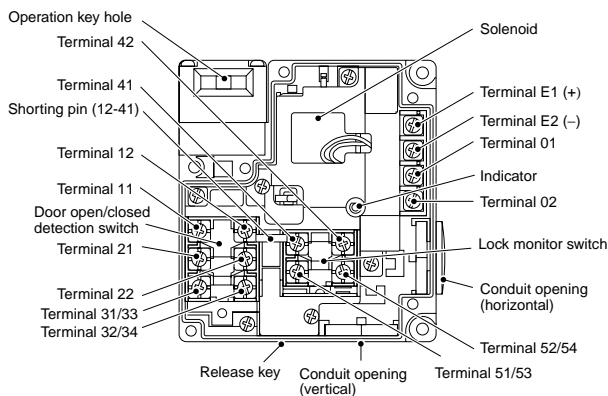

Standard Release Key (Bottom View)

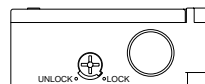

Special Release Key (Bottom View)

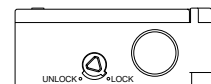

Note: Terminal numbers vary with the model.



OMRON SCIENTIFIC TECHNOLOGIES, INC.
USA Tel. 1/888/510-4357 Canada Tel. 1/866/986-6766

For the Latest Information
On the Internet: www.sti.com or www.omron.ca



D4NL-□□□□-BS

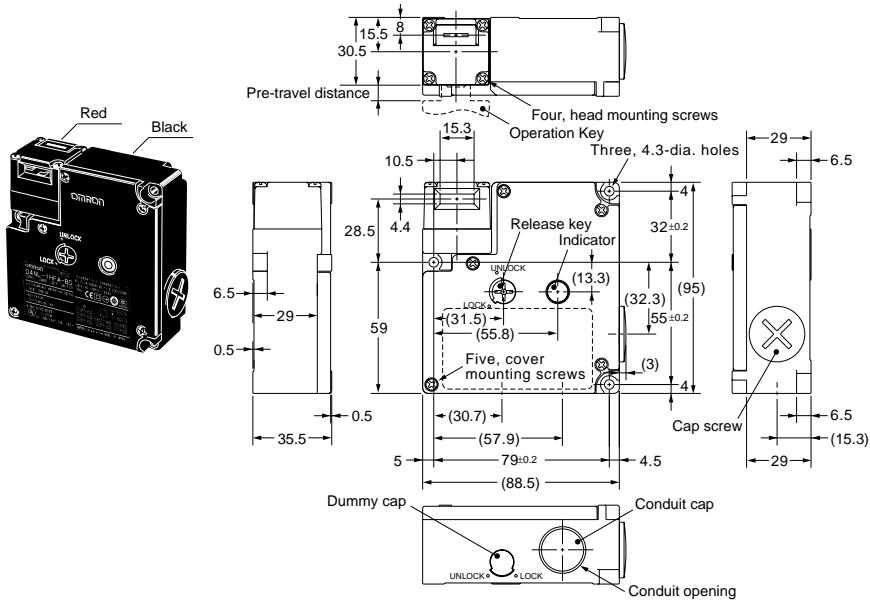

Operating characteristics	D4NL-□□□□-BS
Key insertion force	15 N max.
Key extraction force	30 N max.
Pre-travel distance	9 mm max.
Movement before being locked	3 mm min.

D4NL-□□□□-B4S

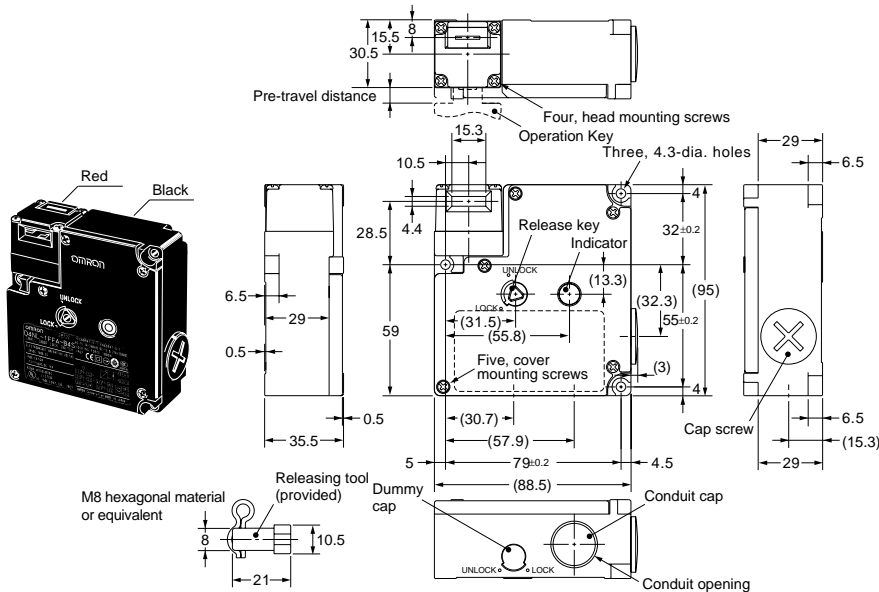

Operating characteristics	D4NL-□□□□-B4S
Key insertion force	15 N max.
Key extraction force	30 N max.
Pre-travel distance	9 mm max.
Movement before being locked	3 mm min.

Operation Keys

Note: Unless otherwise specified, a tolerance of ± 0.4 mm applies to all dimensions.

D4DS-K1

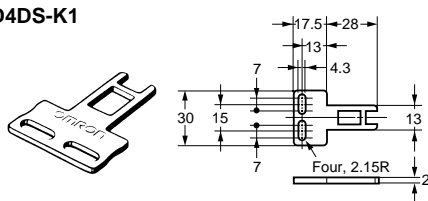

D4DS-K3

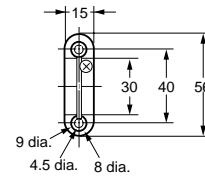
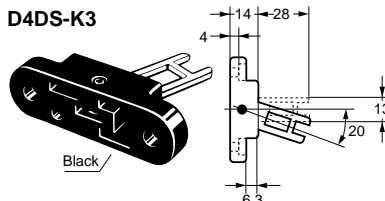

D4DS-K2

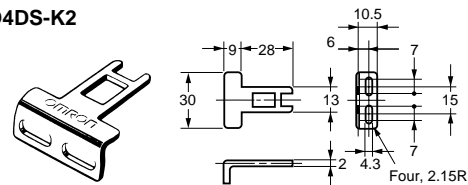

D4DS-K5

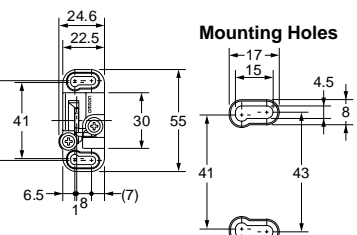
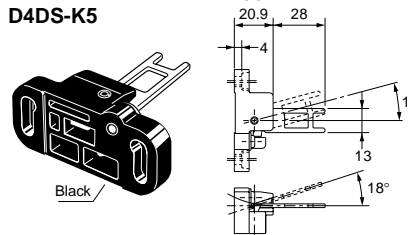

Mounting Holes



OMRON SCIENTIFIC TECHNOLOGIES, INC.
USA Tel. 1/888/510-4357 Canada Tel. 1/866/986-6766

For the Latest Information
On the Internet: www.sti.com or www.omron.ca



Safety Interlock Switches
D4NL

With Operation Key Inserted

D4NL + D4DS-K1

Safety Interlock Switches
D4NL

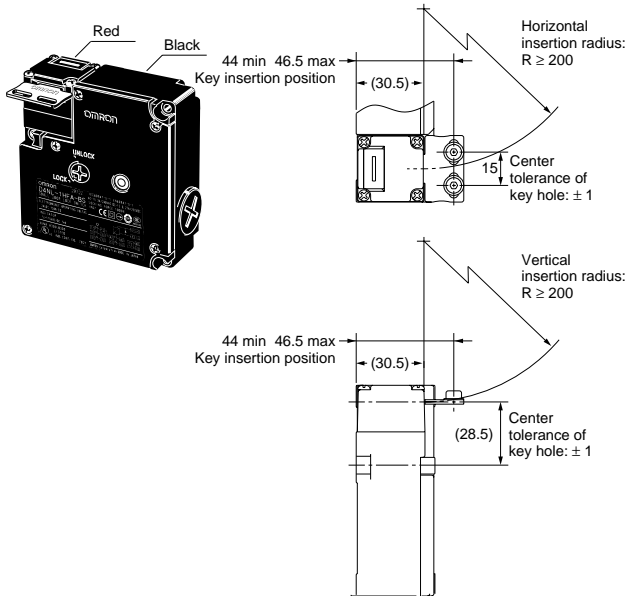

D4NL + D4DS-K2

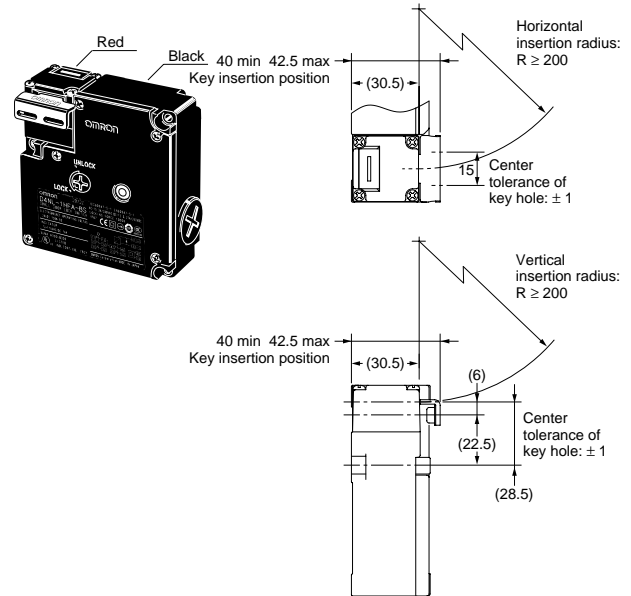

D4NL + D4DS-K3

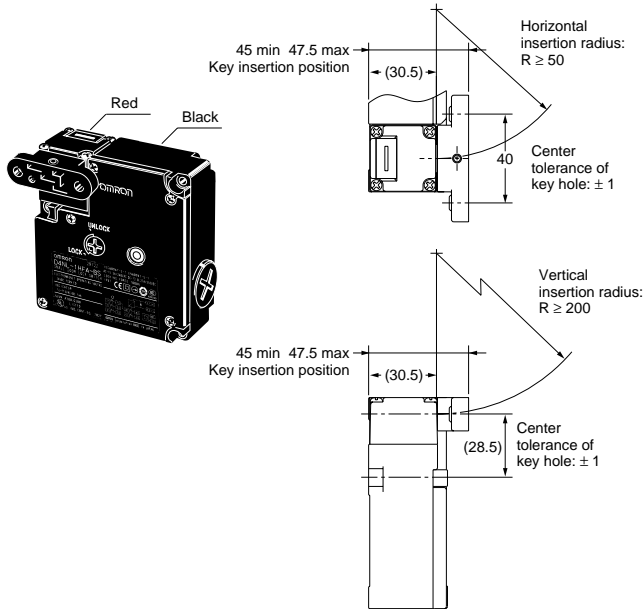

D4NL + D4DS-K5

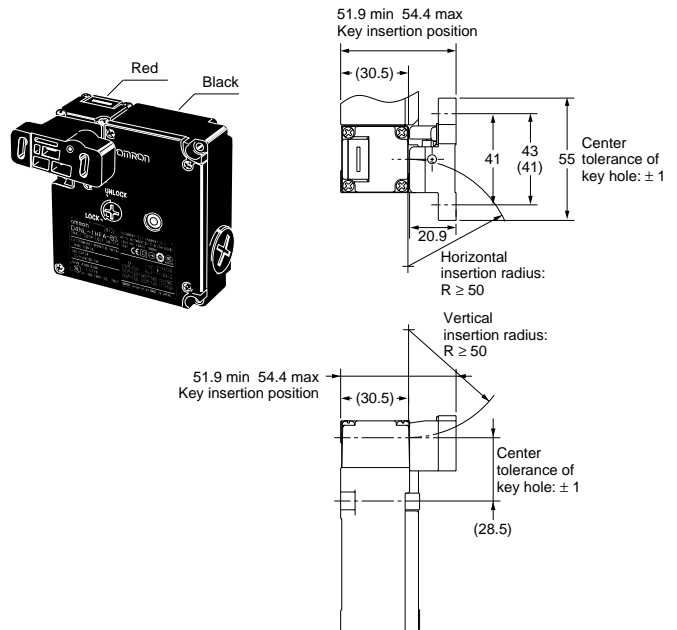

Application Examples

■ G9SA-321-T□ (24 VAC/VDC) + D4NL-□A-□, □B-□, □C-□ (Mechanical Lock Type) Circuit Diagram (Manual Reset)

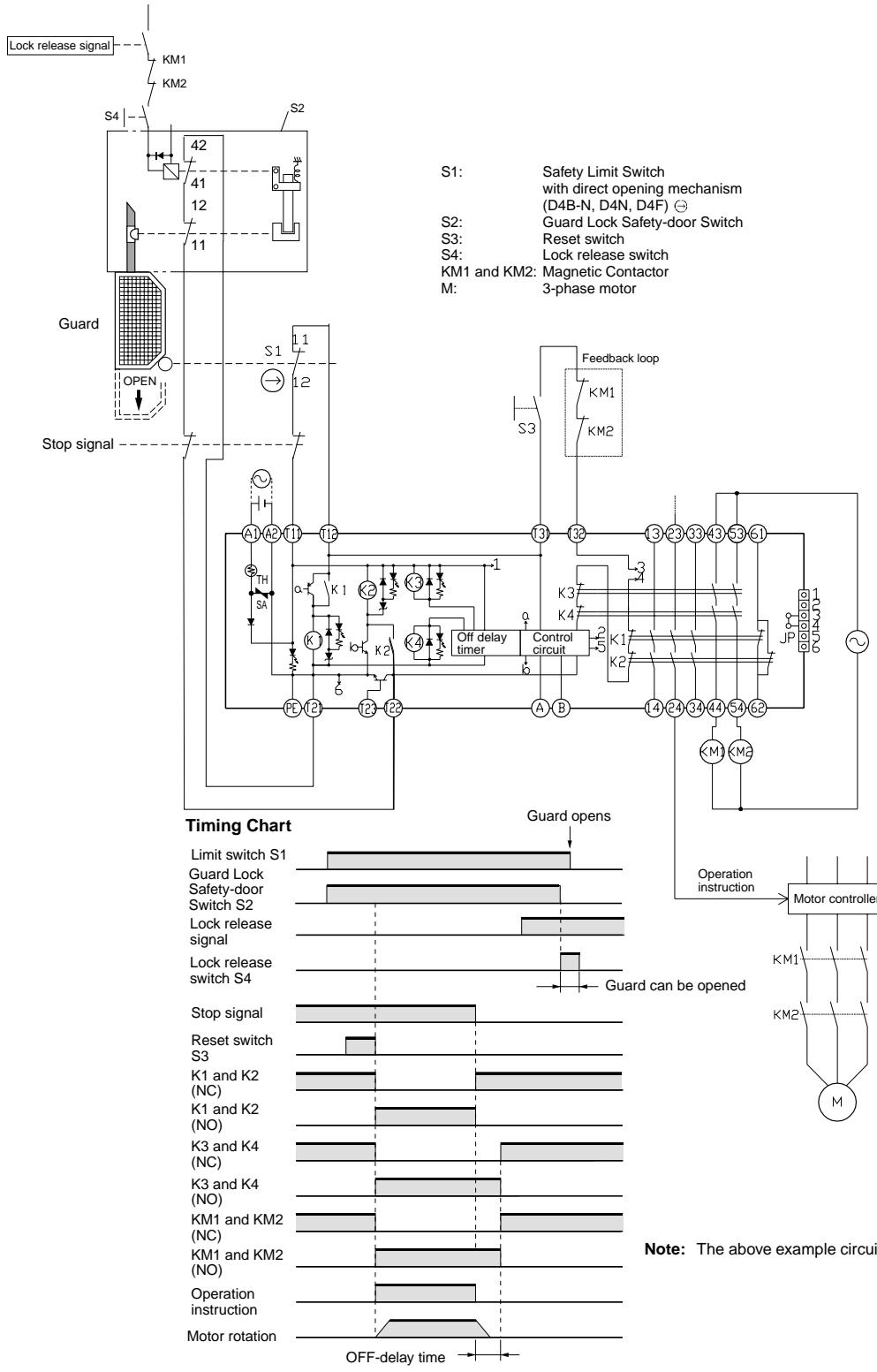

Safety Interlock Switches

D4NL

■ G9SA-301 (24 VAC/VDC) + D4NL-□G-□, □H-□, □J-□ (Solenoid Lock Type) Circuit Diagram (Auto-reset)

Safety Interlock Switches
D4NL

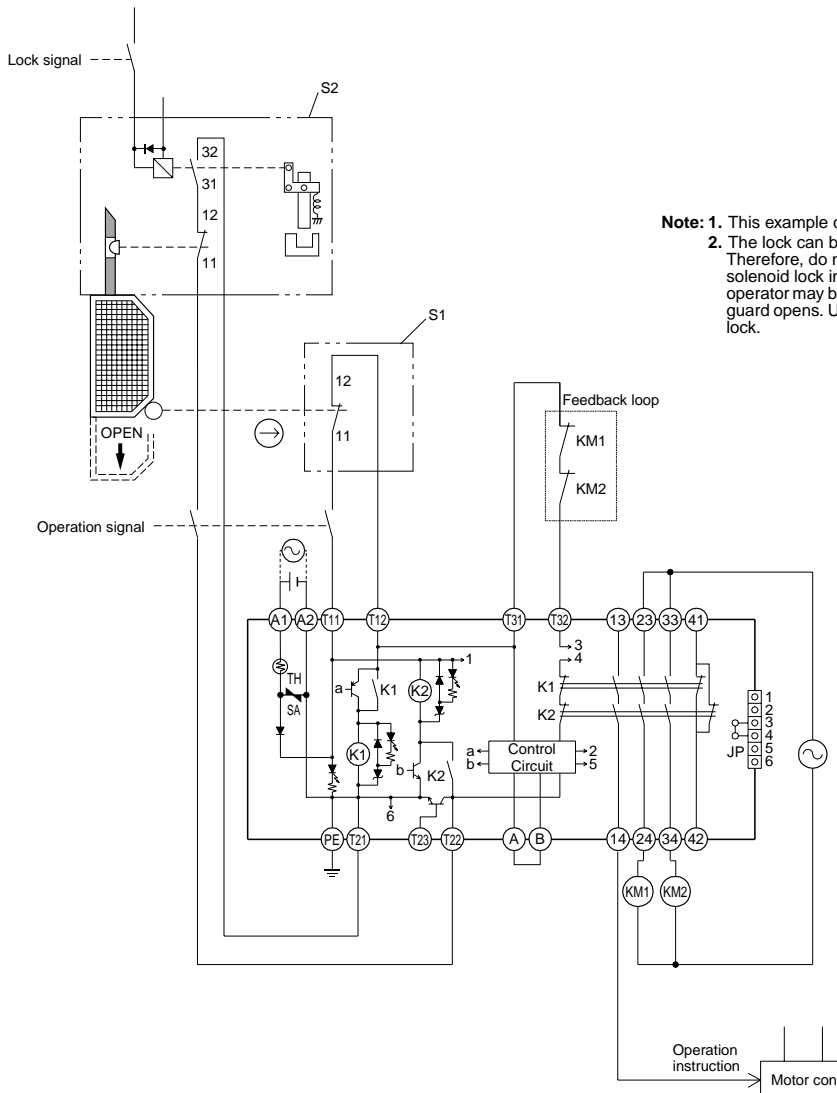

Note: 1. This example circuit is for Category 4.
2. The lock can be released at any time. Therefore, do not use a model with a solenoid lock in applications where the operator may be exposed to danger when the guard opens. Use a model with a mechanical lock.

Timing Chart

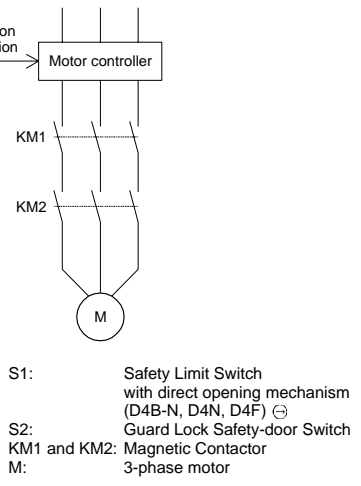
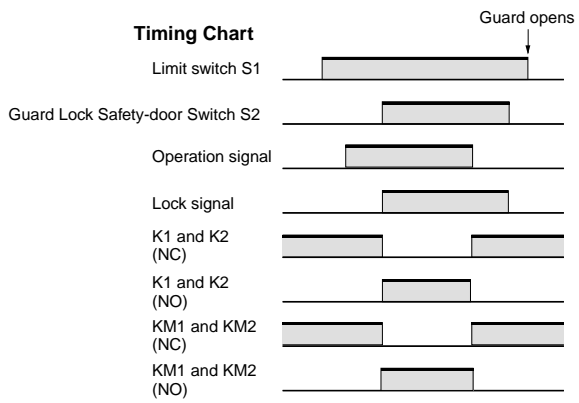

S1: Safety Limit Switch with direct opening mechanism (D4B-N, D4N, D4F) ⊕
 S2: Guard Lock Safety-door Switch
 KM1 and KM2: Magnetic Contactor
 M: 3-phase motor



Safety Precautions

⚠ CAUTION

Change the head direction after changing the release key to the UNLOCK position. Do not change the head direction with the cover removed. Failure to observe these points may result in Switch malfunction or damage.



Holding Force

- Do not apply a force exceeding the specified holding force. Doing so may break the Switch and the machine may continue to operate.
- Either install another locking component (e.g., a stop) in addition to the Switch, or use a warning sticker or an indicator showing the lock status so that a force exceeding the specified holding force is not applied.

■ Precautions for Safe Use

- Do not use the Switch submersed in oil or water or in locations continuously subject to splashes of oil or water. Doing so may result in oil or water entering the Switch. (The IP67 degree of protection of the Switch specifies the amount of water penetration after the Switch is submersed in water for a certain period of time.)
- Although the Switch body is protected from the ingress of dust or water, avoid the ingress of foreign substance through the key hole on the head. Otherwise, accelerated wear or breaking may result.
- Always attach the cover after completing wiring and before using the Switch. Electric shock may occur if the Switch is used without the cover attached.
- When switching general loads (250 VAC/3 A), do not operate two circuits or more at the same time. Otherwise, insulation performance may be degraded.

■ Precautions for Correct Use

The Switch contacts can be used with either standard loads or microloads. Once the contacts have been used to switch a load, however, they cannot be used to switch smaller loads. The contact surfaces will become rough once they have been used and contact reliability for smaller loads may be reduced.

Release Key

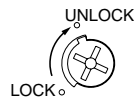

- The release key is used to unlock the Switch in case of emergency or if the power supply to the Switch stops.
- If the release key setting is changed from LOCK to UNLOCK using an appropriate tool, the lock will be released and the safety door can be opened (mechanical lock models only).
- After setting the release key to UNLOCK to, for example, change the head direction or perform maintenance, be sure to return it to LOCK setting before resuming operation.
- If the release key is set to UNLOCK when the Switch is used for the door of a machine room to ensure the safety of people performing adjustment work inside, the door will not be locked when the door is closed and no power will be supplied to the equipment.
- Do not use the release key to start or stop machines.
- The auxiliary lock must only be released by authorized personnel.
- Do not impose a force exceeding 1 N-m on the release key screws. The release key may be damaged and may not operated properly.
- To prevent the release key from being used by unauthorized personnel, set it to LOCK and seal it with sealing wax.

Hinged Door

If an attempt is made to open the door beyond the lock position when the Switch is used for a hinged door at a location near to the hinged side, where the Operation Key's insertion radius is comparatively small, the force imposed will be much larger than for locations far from the hinged side, and the lock may be damaged.

Solenoid Lock Models

The solenoid lock locks the door only when power is supplied to the solenoid. Therefore, the door will be unlocked if the power supply to the solenoid stops. Therefore, do not use solenoid lock models for machines that may be operating and dangerous even after the machine stops operating.

Life Expectancy

The life expectancy of the Switch will vary with the switching conditions. Before applying the Switch, test it under actual operating conditions and be sure to use it at a switching frequency that will not lower its performance.

Mounting

Tightening Torque

Be sure to tighten each screw of the Switch properly. Loose screws may result in malfunction.

Type	Tightening torque
Terminal screw	0.59 to 0.78 N-m
Cover mounting screw	0.49 to 0.69 N-m
Head mounting screw	0.49 to 0.59 N-m
Operation Key mounting screw	2.35 to 2.75 N-m
Switch mounting screw	0.49 to 0.69 N-m
Connector	1.77 to 2.16 N-m
Cap screw	1.27 to 1.67 N-m

Switch and Operation Key Mounting

- Mount the Switch and Operation Key securely to the applicable tightening torque with M4 screws.

Mounting Holes for Switches

Mounting Holes for Operation Keys

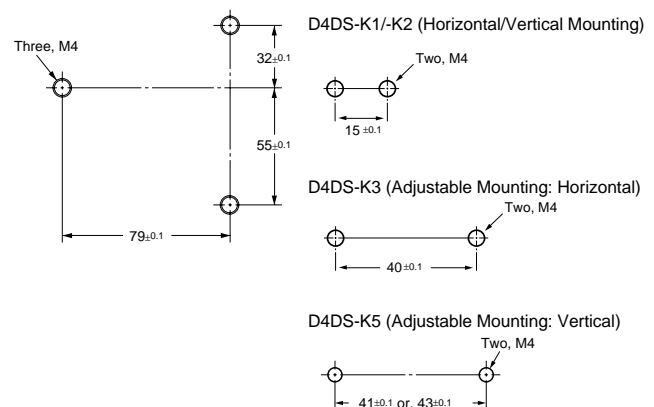

- If the Switch is back-mounted, the release key can be operated only from the bottom and the indicator cannot be used.
- Use the designated OMRON Operation Key with the Switch. Using another Operation Key may result in Switch damage.
- Ensure that the alignment offset between the Operation Key and the key hole does not exceed ± 1 mm.
- Observe the specified insertion radius for the Operation Key and insert it in a direction perpendicular to the key hole.

Head Direction

1. Switch the release key to the UNLOCK position.
2. Remove the four screws of the head to enable changing the mounting direction of the head. The head can be mounted in four directions.
Ensure that no foreign material enters the interior of the Switch. Also, insert the head until the insertion line engraved on the head is hidden by the reference line on the Switch, as shown in the following diagram.
3. Return the release key to the LOCK position.

Securing the Door

When the door is closed (with the Operation Key inserted), it may be pulled beyond the set zone because of, for example, the door's weight, or the door cushion rubber. Also, if a load is applied to the Operation Key, the door may fail to unlock properly. Use hooks to ensure that the door stays within the set zone.

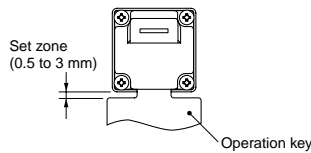

Wiring

Wiring Precautions

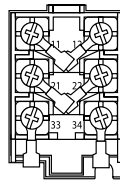

- When connecting to the terminals via insulating tube and M3.5 crimp terminals, cross the crimp terminals as shown above so that they do not rise up onto the case or the cover. Applicable lead wire size: AWG20 to AWG18 (0.5 to 0.75mm²).
- When connecting lead wires directly to terminals, perform wiring securely so that there are no loose wire strands.
- Do not push crimp terminals into gaps in the case interior. Doing so may cause damage or deformation of the case.
- Use lead wires of an appropriate length. Not doing so may cause the cover to rise.
- Use crimp terminals not more than 0.5 mm in thickness. Otherwise, they will interfere with other components inside the case. The crimp terminals shown below are not more than 0.5 mm thick.

Manufacturer	Model	Applicable lead wire size
J.S.T. Mfg Co.	FV0.5-3.7	AWG20 (0.5 mm ²)

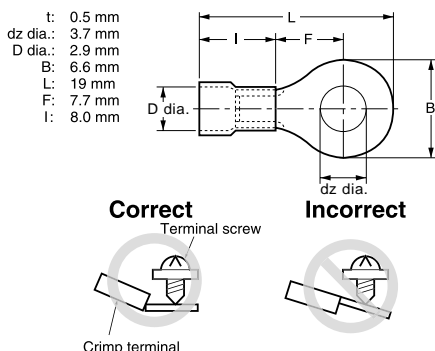

Conduit Opening

- Connect a recommended connector to the opening of the conduit and tighten the connector to the proper torque. The case may be damaged if an excessive tightening torque is applied.
- To ensure IP67 degree of protection, wrap sealing tape around the conduit end of the connector.
- Be sure that the outer diameter of the cable connected to the connector is correct.
- Attach and tighten a conduit cap to the unused conduit opening when wiring. The conduit cap is provided with the Switch.

Recommended Connectors

Use a connector with a screw section not exceeding 11 mm, otherwise the screws will protrude into the case interior. The connectors given in the following table have connectors with screw sections not exceeding 11 mm.

Use the following connectors to ensure conformance to IP67.

Size	Manufacturer	Model	Applicable cable diameter
G ¹ / ₂	LAPP	ST-PF1/2 5380-1002	6.0 to 12.0 mm
	OHM ELECTRIC CO.	OA-W1609	7.0 to 9.0 mm
		OA-W1611	9.0 to 11.0 mm
Pg13.5	LAPP	S-13.5 5301-5030	5.0 to 12.0 mm
M20	LAPP	ST-M20 × 1.5 5311-1020	7.0 to 13.0 mm

Use LAPP connectors together with Seal Packing (JPK-16, GP-13.5, or GPM20), and tighten with the applicable torque. Seal Packing is sold separately.

Miscellaneous

- Do not touch the solenoid. The temperature of the solenoid increases when current is passed.

List of Recommended Substitute Products**Switch**

D4DL product	Recommended substitute product
D4DL-1CFA-B	D4NL-1AFA-B, D4NL-1BFA-B
D4DL-2CFA-B	D4NL-2AFA-B, D4NL-2BFA-B
D4DL-1DFA-B	D4NL-1CFA-B, D4NL-1DFA-B
D4DL-2DFA-B	D4NL-2CFA-B, D4NL-2DFA-B
D4DL-1CFG-B	D4NL-1AFG-B, D4NL-1BFG-B
D4DL-2CFG-B	D4NL-2AFG-B, D4NL-2BFG-B
D4DL-1DFG-B	D4NL-1CFG-B, D4NL-1DFG-B
D4DL-2DFG-B	D4NL-2CFG-B, D4NL-2DFG-B
D4DL-1CFB-B	D4NL-1AFB-B, D4NL-1BFB-B
D4DL-2CFB-B	D4NL-2AFB-B, D4NL-2BFB-B
D4DL-1DFB-B	D4NL-1CFB-B, D4NL-1DFB-B
D4DL-2DFB-B	D4NL-2CFB-B, D4NL-2DFB-B
D4DL-1CFH-B	D4NL-1AFH-B, D4NL-1BFH-B
D4DL-2CFH-B	D4NL-2AFH-B, D4NL-2BFH-B
D4DL-1DFH-B	D4NL-1CFH-B, D4NL-1DFH-B
D4DL-2DFH-B	D4NL-2CFH-B, D4NL-2DFH-B
D4DL-1CFC-E*	D4NL-1AFC-B, D4NL-1BFC-B
D4DL-2CFC-E*	D4NL-2AFC-B, D4NL-2BFC-B
D4DL-1DFC-E*	D4NL-1CFC-B, D4NL-1DFC-B
D4DL-2DFC-E*	D4NL-2CFC-B, D4NL-2DFC-B
D4DL-1CFJ-E*	D4NL-1AFJ-B, D4NL-1BFJ-B
D4DL-2CFJ-E*	D4NL-2AFJ-B, D4NL-2BFJ-B
D4DL-1DFJ-E*	D4NL-1CFJ-B, D4NL-1DFJ-B
D4DL-2DFJ-E*	D4NL-2CFJ-B, D4NL-2DFJ-B
D4DL-1CFA-B-HT	D4NL-1AFA-B4, D4NL-1BFA-B4
D4DL-2CFA-B-HT	D4NL-2AFA-B4, D4NL-2BFA-B4
D4DL-1DFA-B-HT	D4NL-1CFA-B4, D4NL-1DFA-B4
D4DL-2DFA-B-HT	D4NL-2CFA-B4, D4NL-2DFA-B4
D4DL-1CFG-B-HT	D4NL-1AFG-B4, D4NL-1BFG-B4
D4DL-2CFG-B-HT	D4NL-2AFG-B4, D4NL-2BFG-B4
D4DL-1DFG-B-HT	D4NL-1CFG-B4, D4NL-1DFG-B4
D4DL-2DFG-B-HT	D4NL-2CFG-B4, D4NL-2DFG-B4

Note: With standard products, terminals 12 and 41 are connected with a shorting pin. If D4DL terminals 11 and 12 and terminals 41 and 42 are currently being used independently, remove the shorting pin.

* Use a voltage of 115 VAC/VDC max. for the D4NL-□□□□-B. Do not apply a voltage exceeding 115 VAC/VDC.

Operation Keys

- D4DS-K1
- D4DS-K2
- D4DS-K3
- D4DS-K5

All of the above Operation Keys can be used with the D4NL.

ALL DIMENSIONS SHOWN ARE IN MILLIMETERS.

To convert millimeters into inches, multiply by 0.03937. To convert grams into ounces, multiply by 0.03527.

In the interest of product improvement, specifications are subject to change without notice.



OMRON SCIENTIFIC TECHNOLOGIES, INC.
USA Tel. 1/888/510-4357 Canada Tel. 1/866/986-6766



For the Latest Information
On the Internet: www.sti.com or www.omron.ca

OMRON