

Dual 1 Form A/B, C Solid State Relay

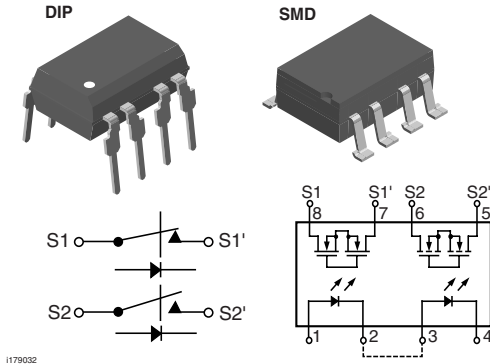

1179032

DESCRIPTION

The LH1502 relays contain normally open and normally closed switches that can be used independently as a 1 form A and 1 form B relay, or when used together, as a 1 form C relay. The relays are constructed as a multi-chip hybrid device. Actuation control is via an infrared LED. The output switch is a combination of a photodiode array with MOSFET switches and control circuitry.

FEATURES

- Current limit protection
- Isolation test voltage 3750 V_{RMS}
- Typical R_{ON} 20 Ω
- Load voltage 350 V
- Load current 150 mA
- High surge capability
- Clean bounce free switching
- Low power consumption
- SMD lead available on tape and reel
- Lead (Pb)-free component
- Component in accordance to RoHS 2002/95/EC and WEEE 2002/96/EC



RoHS
COMPLIANT

APPLICATIONS

- General telecom switching
 - On/off hook control
 - Ring delay
 - Dial pulse
 - Ground start
 - Ground fault protection
- Instrumentation
- Industrial controls

AGENCY APPROVALS

UL1577: file no. E52744 system code H or J, double protection

CSA: certification 093751

ORDER INFORMATION

PART	REMARKS	PACKAGE
LH1502BAC	Tubes	SMD-8
LH1502BACTR	Tape and reel	SMD-8
LH1502BB	Tubes	DIP-8

ABSOLUTE MAXIMUM RATINGS (1)

PARAMETER	TEST CONDITION	SYMBOL	VALUE	UNIT
SSR				
LED continuous forward current		I _F	50	mA
LED reverse voltage	I _R ≤ 10 μA	V _R	8.0	V
DC or peak AC load voltage	I _L ≤ 50 μA	V _L	350	V
Continuous DC load current (form C operation)		I _L	150	mA
Peak load current, form A	t = 100 ms	I _P	(4)	
Peak load current (single shot), form B		I _P	350	mA

LH1502BAC, LH1502BACTR, LH1502BB



Vishay Semiconductors Dual 1 Form A/B, C Solid State Relay

ABSOLUTE MAXIMUM RATINGS (1)				
PARAMETER	TEST CONDITION	SYMBOL	VALUE	UNIT
SSR				
Ambient operating temperature range		T_{amb}	- 40 to + 85	°C
Storage temperature range		T_{stg}	- 40 to + 125	°C
Pin soldering temperature (2)	$t = 10$ s max.	T_{sld}	260	°C
Input to output isolation test voltage	$t = 1.0$ s, $I_{ISO} = 10$ μ A max.	V_{ISO}	3750	V_{RMS}
Pole-to-pole isolation voltage (S1 to S2) (3), (dry air, dust free, at sea level)			1600	V
Output power dissipation (continuous)		P_{diss}	600	mW

Notes

(1) $T_{amb} = 25$ °C, unless otherwise specified.

Stresses in excess of the absolute maximum ratings can cause permanent damage to the device. Functional operation of the device is not implied at these or any other conditions in excess of those given in the operational sections of this document. Exposure to absolute maximum ratings for extended periods of the time can adversely affect reliability.

(2) Refer to reflow profile for soldering conditions for surface mounted devices (SMD). Refer to wave profile for soldering conditions for through hole devices (DIP).

(3) Breakdown occurs between the output pins external to the package.

(4) Refer to current limit performance application note for a discussion on relay operation during transient currents.

ELECTRICAL CHARACTERISTICS						
PARAMETER	TEST CONDITION	SYMBOL	MIN.	TYP.	MAX.	UNIT
INPUT						
LED forward current, switch turn-on (NO)	$I_L = 100$ mA, $t = 10$ ms	I_{Fon}		0.6	2.0	mA
LED forward current, switch turn-off (NO)	$V_L = \pm 300$ V	I_{Foff}	0.4	0.5		mA
LED forward current, switch turn-on (NC)	$I_L = 300$ mA, $t = 10$ ms	I_{Fon}	0.2	0.9		mA
LED forward current, switch turn-off (NC)	$V_L = \pm 300$ V	I_{Foff}		1.0	2.0	mA
LED forward voltage	$I_F = 10$ mA	V_F	1.15	1.26	1.45	V
OUTPUT						
On-resistance (NO, NC)	$I_F = 5.0$ mA (NO), $I_F = 0$ mA (NC), $I_L = 50$ mA (NC)	R_{ON}	12	20	25	Ω
Off-resistance (NO)	$I_F = 0$ mA, $V_L = \pm 100$ V	R_{OFF}	0.35	5000		G Ω
Off-resistance (NC)	$I_F = 5.0$ mA, $V_L = \pm 100$ V	R_{OFF}	0.1	1.4		G Ω
Current limit (NO)	$I_F = 5.0$ mA, $t = 5.0$ ms, $V_L = \pm 5.0$ V	I_{LMT}	270	290	380	mA
Off-state leakage current (NO)	$I_F = 0$ mA, $V_L = \pm 100$ V	I_O		0.02	1000	nA
Off-state leakage current (NC)	$I_F = 5.0$ mA, $V_L = \pm 100$ V	I_O		0.07	1.0	μ A
Off-state leakage current (NO, NC)	$I_F = 0$ mA (NO), $I_F = 5.0$ mA (NC), $V_L = \pm 200$ V	I_O			1.0	μ A
Output capacitance (NO)	$I_F = 0$ mA, $V_L = 50$ V	C_O		50		pF
Output capacitance (NC)	$I_F = 5.0$ mA, $V_L = 50$ V	C_O		50		pF
TRANSFER						
Capacitance (input to output)	$V_{ISO} = 1.0$ V	C_{IO}		3.0		pF
Turn-on time (NO)	$I_F = 10$ mA, $I_L = 37.5$ mA, $V_L = 150$ V	t_{on}	0.2	3.2	6.0	ms
Turn-on time (NC)	$I_F = 10$ mA, $I_L = 37.5$ mA, $V_L = 150$ V	t_{on}	0.2	3.8	6.0	ms
Turn-off time (NO)	$I_F = 10$ mA, $I_L = 37.5$ mA, $V_L = 150$ V	t_{off}		1.6	3.0	ms
Turn-off time (NC)	$I_F = 10$ mA, $I_L = 37.5$ mA, $V_L = 150$ V	t_{off}		0.8	3.0	ms

Note

$T_{amb} = 25$ °C, unless otherwise specified.

Minimum and maximum values are testing requirements. Typical values are characteristics of the device and are the result of engineering evaluation. Typical values are for information only and are not part of the testing requirements.



LH1502BAC, LH1502BACTR, LH1502BB

Dual 1 Form A/B, C Solid State Relay Vishay Semiconductors

TYPICAL CHARACTERISTICS

T_{amb} = 25 °C, unless otherwise specified

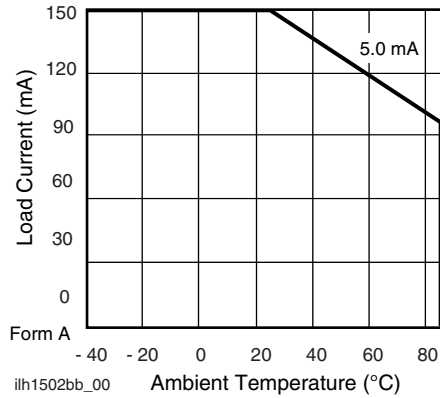

Fig. 1 - Recommended Operating Conditions

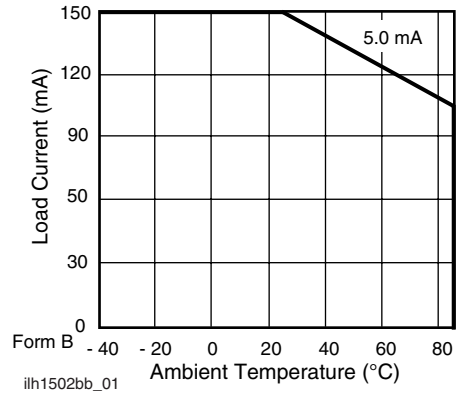
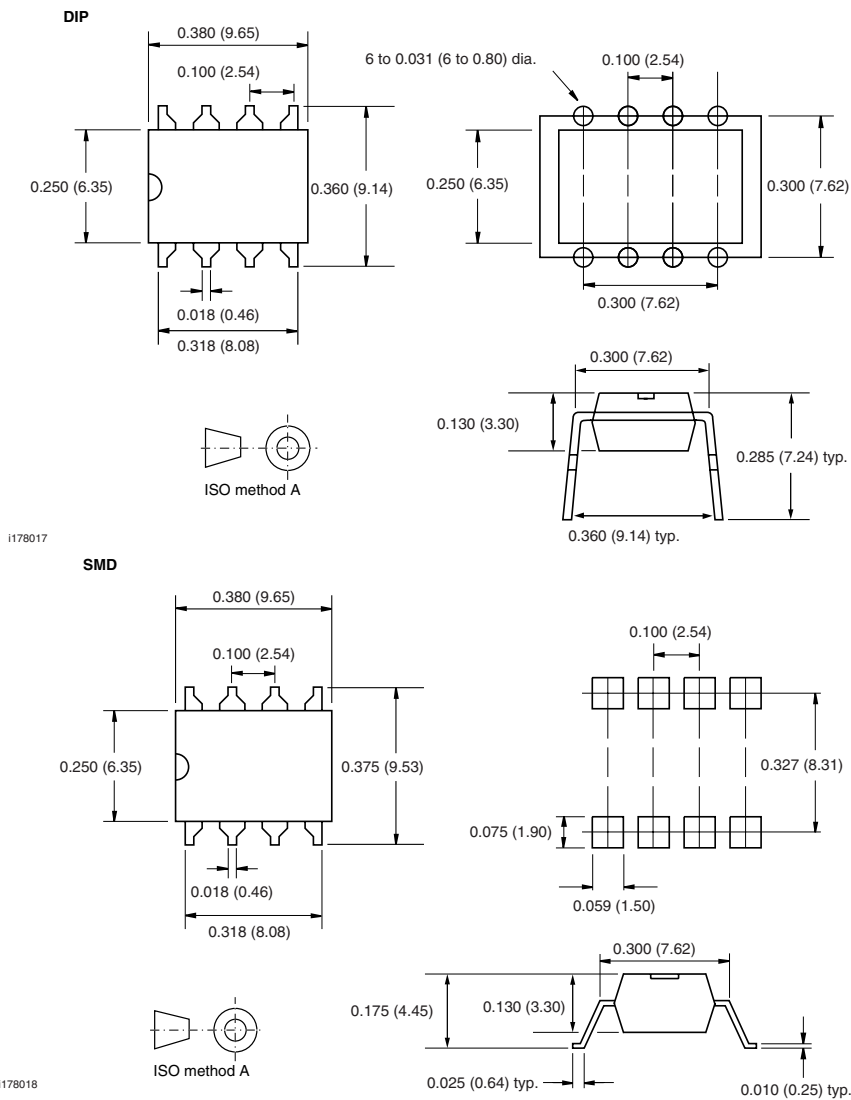

Fig. 2 - Recommended Operating Conditions

PACKAGE DIMENSIONS in inches (millimeters)





OZONE DEPLETING SUBSTANCES POLICY STATEMENT

It is the policy of Vishay Semiconductor GmbH to

1. Meet all present and future national and international statutory requirements.
2. Regularly and continuously improve the performance of our products, processes, distribution and operating systems with respect to their impact on the health and safety of our employees and the public, as well as their impact on the environment.

It is particular concern to control or eliminate releases of those substances into the atmosphere which are known as ozone depleting substances (ODSs).

The Montreal Protocol (1987) and its London Amendments (1990) intend to severely restrict the use of ODSs and forbid their use within the next ten years. Various national and international initiatives are pressing for an earlier ban on these substances.

Vishay Semiconductor GmbH has been able to use its policy of continuous improvements to eliminate the use of ODSs listed in the following documents.

1. Annex A, B and list of transitional substances of the Montreal Protocol and the London Amendments respectively.
2. Class I and II ozone depleting substances in the Clean Air Act Amendments of 1990 by the Environmental Protection Agency (EPA) in the USA.
3. Council Decision 88/540/EEC and 91/690/EEC Annex A, B and C (transitional substances) respectively.

Vishay Semiconductor GmbH can certify that our semiconductors are not manufactured with ozone depleting substances and do not contain such substances.

We reserve the right to make changes to improve technical design
and may do so without further notice.

Parameters can vary in different applications. All operating parameters must be validated for each customer application by the customer. Should the buyer use Vishay Semiconductors products for any unintended or unauthorized application, the buyer shall indemnify Vishay Semiconductors against all claims, costs, damages, and expenses, arising out of, directly or indirectly, any claim of personal damage, injury or death associated with such unintended or unauthorized use.

Vishay Semiconductor GmbH, P.O.B. 3535, D-74025 Heilbronn, Germany



Disclaimer

ALL PRODUCT, PRODUCT SPECIFICATIONS AND DATA ARE SUBJECT TO CHANGE WITHOUT NOTICE TO IMPROVE RELIABILITY, FUNCTION OR DESIGN OR OTHERWISE.

Vishay Intertechnology, Inc., its affiliates, agents, and employees, and all persons acting on its or their behalf (collectively, "Vishay"), disclaim any and all liability for any errors, inaccuracies or incompleteness contained in any datasheet or in any other disclosure relating to any product.

Vishay makes no warranty, representation or guarantee regarding the suitability of the products for any particular purpose or the continuing production of any product. To the maximum extent permitted by applicable law, Vishay disclaims (i) any and all liability arising out of the application or use of any product, (ii) any and all liability, including without limitation special, consequential or incidental damages, and (iii) any and all implied warranties, including warranties of fitness for particular purpose, non-infringement and merchantability.

Statements regarding the suitability of products for certain types of applications are based on Vishay's knowledge of typical requirements that are often placed on Vishay products in generic applications. Such statements are not binding statements about the suitability of products for a particular application. It is the customer's responsibility to validate that a particular product with the properties described in the product specification is suitable for use in a particular application. Parameters provided in datasheets and/or specifications may vary in different applications and performance may vary over time. All operating parameters, including typical parameters, must be validated for each customer application by the customer's technical experts. Product specifications do not expand or otherwise modify Vishay's terms and conditions of purchase, including but not limited to the warranty expressed therein.

Except as expressly indicated in writing, Vishay products are not designed for use in medical, life-saving, or life-sustaining applications or for any other application in which the failure of the Vishay product could result in personal injury or death. Customers using or selling Vishay products not expressly indicated for use in such applications do so at their own risk and agree to fully indemnify and hold Vishay and its distributors harmless from and against any and all claims, liabilities, expenses and damages arising or resulting in connection with such use or sale, including attorneys fees, even if such claim alleges that Vishay or its distributor was negligent regarding the design or manufacture of the part. Please contact authorized Vishay personnel to obtain written terms and conditions regarding products designed for such applications.

No license, express or implied, by estoppel or otherwise, to any intellectual property rights is granted by this document or by any conduct of Vishay. Product names and markings noted herein may be trademarks of their respective owners.