

General-purpose Relay MY

An Improved Miniature Power Relay with Many Models for Sequence Control and Power Applications

- A wide range of relay variations including ones with operation indicators, built-in diodes, etc.
- Arc barrier standard on 3- and 4-pole Relays.
- Dielectric strength: 2,000 VAC.

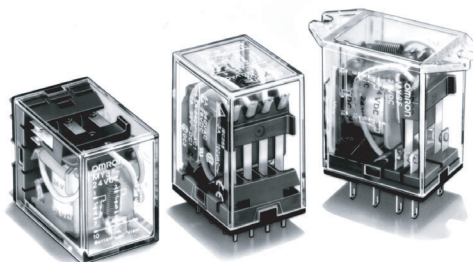

Ordering Information

List of Models

Type	Contact form	Plug-in socket/solder terminals		PCB terminals	Upper-mounting/solder terminals
			With indicator		
Standard	DPDT	---	---	MY2-02	MY2F
	3PDT	MY3	MY3N	MY3-02	MY3F
	4PDT	---	---	MY4-02	MY4F
	4PDT (bifurcated)	---	---	MY4Z-02	MY4ZF
With built-in diode (DC only)	3PDT	MY3-D	MY3N-D2	---	---

Note: When ordering, add the rated coil voltage to the model number. Rated coil voltages are given in the coil ratings table.

Example: MY3, 6 VAC

Accessories (Order Separately)

Sockets

Poles	Front-mounting Socket (DIN-track/screw mounting)	Back-mounting Socket				
		Solder terminals		Wire-wrap terminals		PCB terminals
		W/ clip	W/o clip	W/ clip	W/o clip	
3	PYF11A	PY11	PY11-Y1	PY11QN	PY11QN-Y1	PY11-02

- Note: 1. Equipped with operation check terminal.
 2. The PYF08A(-E), PYF11A, and PYF14A(-E) have been approved as individual Sockets by UL 508 and CSA C22.2.

Mounting Plates for Sockets

Socket model	For 1 Socket	For 18 Sockets	For 36 Sockets
PY11, PY11QN(2)	PYP-1	PYP-18	PYP-36

Note: PYP-18 and PYP-36 can be cut into any desired length in accordance with the number of Sockets.

Socket Hold-down Clip Pairing

Relay type	Poles	Front-connecting Sockets (track-/screw-mounted)		Back-connecting Sockets			
				Solder/wire-wrap terminals		PCB terminals	
		Socket	Clip	Socket	Clip	Socket	Clip
Standard, operation indicator, built-in diode	3	PYF11A	PYC-A1	PY11(QN)	PYC-P	PY11-02	PYC-P

Specifications

■ Coil Ratings

	Rated voltage	Rated current		Coil resistance	Coil inductance (reference value)		Must operate voltage	Must release voltage	Max. voltage	Power consum. (Approx.)
		50 Hz	60 Hz		Arm. OFF	Arm. ON				
AC	6 V	214.1 mA	183 mA	12.2 Ω	0.04 H	0.08 H	80% max.	30% min.	110%	1.0 to 1.2 VA (60 Hz)
	12 V	106.5 mA	91 mA	46 Ω	0.17 H	0.33 H				
	24 V	53.8 mA	46 mA	180 Ω	0.69 H	1.30 H				
	50 V	25.7 mA	22 mA	788 Ω	3.22 H	5.66 H				
	100/110 V	11.7/12.9 mA	10/11 mA	3,750 Ω	14.54 H	24.6 H				0.9 to 1.1 VA (60 Hz)
	110/120 V	9.9/10.8 mA	8.4/9.2 mA	4,430 Ω	19.20 H	32.1 H				
	200/220 V	6.2/6.8 mA	5.3/5.8 mA	12,950 Ω	54.75 H	94.07 H				
	220/240 V	4.8/5.3 mA	4.2/4.6 mA	18,790 Ω	83.50 H	136.40 H				
DC	6 V	150 mA		40 Ω	0.17 H	0.33 H	10% min.		0.9 W	
	12 V	75 mA		160 Ω	0.73 H	1.37 H				
	24 V	36.9 mA		650 Ω	3.20 H	5.72 H				
	48 V	18.5 mA		2,600 Ω	10.60 H	21.00 H				
	100/110 V	9.1/10 mA		11,000 Ω	45.60 H	86.20 H				

- Note:**
- The rated current and coil resistance are measured at a coil temperature of 23°C with tolerances of +15%/–20% for rated currents and ±15% for DC coil resistance.
 - Performance characteristic data are measured at a coil temperatures of 23°C.
 - AC coil resistance and impedance are provided as reference values (at 60 Hz).
 - Power consumption drop was measured for the above data. When driving transistors, check leakage current and connect a bleeder resistor if required.

■ Contact Ratings

Item	Double- or three-pole		Four-pole	
	Resistive load ($\cos\phi = 1$)	Inductive load ($\cos\phi=0.4$, L/R=7 ms)	Resistive load ($\cos\phi = 1$)	Inductive load ($\cos\phi=0.4$, L/R=7 ms)
Rated load	5 A, 220 VAC 5 A, 24 VDC	2 A, 220 VAC 2 A, 24 VDC	3 A, 220 VAC 3 A, 24 VDC	0.8 A, 220 VAC) 1.5 A, 24 VDC
Carry current	5 A		3 A	
Max. switching voltage	250 VAC 125 VDC		250 VAC 125 VDC	
Max. switching current	5 A	5 A	3 A	3 A
Max. switching power	1,100 VA 120 W	440 VA 48 W	660 VA 72 W	176 VA 36 W
Failure rate (reference value)*	Standard type: 100 mA, 5 VDC		Standard types: 1 mA, 1 VDC Bifurcated type: 100 μA, 1 VDC	

*Note: P level: $\lambda_{60} = 0.1 \times 10^{-6}$ /operation, reference value

■ Characteristics

Item	All Relays
Contact resistance	50 mΩ max.
Operate time	20 ms max.
Release time	20 ms max.
Max. operating frequency	Mechanical: 18,000 operations/hr Electrical: 1,800 operations/hr (under rated load)
Insulation resistance	1,000 MΩ min. (at 500 VDC)
Dielectric strength	2,000 VAC, 50/60 Hz for 1 min (1,000 VAC between contacts of same polarity)
Vibration resistance	Destruction: 10 to 55 to 10 Hz, 0.5 mm single amplitude (1.0 mm double amplitude) Malfunction: 10 to 55 to 10 Hz, 0.5 mm single amplitude (1.0 mm double amplitude)
Shock resistance	Destruction: 1,000 m/s ² Malfunction: 200 m/s ²
Endurance	See following table.
Ambient temperature*	Operating: (standard): -55°C to 70°C (with no icing) Built-in LED indicator; built-in diode: -55°C to 60°C (with no icing)
Ambient humidity	Operating: 5% to 85%
Weight	Approx. 35 g

Note: The values given above are initial values.

Endurance Characteristics

Contact form	Mechanical life (at 18,000 operations/hr)	Electrical life (at 1,800 operations/hr under rated load)
Normal	AC: 50,000,000 operations min. DC: 100,000,000 operations min.	2-,3-pole: 500,000 operations min. 4-pole: 200,000 operations min.
With bifurcated contacts	4-pole: 20,000,000 operations min.	4-pole: 100,000 operations min.

Note: See following tables for real load life expectancies.

■ Endurance Under Real Loads

MY2

Rated voltage	Load type	Conditions	Operating frequency	Electrical life
100 VAC	AC motor	50 W, 100 VAC single-phase with 2.8-A inrush current, 0.4-A carry current	ON for 2 s, OFF for 30 s	100,000 operations
		50 W, 100 VAC single-phase with 1.6-A inrush current, 1-A carry current	ON for 1 s, OFF for 30 s	300,000 operations
	AC solenoid	24 W with 1-A carry current	ON for 1.5 s, OFF for 1.5 s	4,000,000 operations

MY4

Rated voltage	Load type	Conditions	Operating frequency	Electrical life
100 VAC	AC solenoid	50 VA with 2-A inrush current, 0.7-A carry current	ON for 1 s, OFF for 3 s	25,000 operations
	DC magnetic switch	25 W with L/R = 40 ms, 0.2-A carry current		
	AC magnetic switch	35 VA with 1.5-A inrush current, 0.35-A carry current		500,000 operations
24 VDC	DC solenoid	40 W with L/R = 10 ms, 1.6-A carry current	ON for 0.5 s, OFF for 1.5 s	5,000,000 operations
		30 W with L/R = 10 ms with 0.34-A carry current	ON for 0.5 s, OFF for 1.5 s	6,000,000 operations

■ Approved Standards

Some MY Relays are available in models meeting various safety standards. When ordering, you must specify the desired standards. Refer to *Ordering Information* for specific models. Note that the rating recognized by the various standards sometimes vary from the ratings of the individual Relays.

UL 508 Recognitions (File No. 41515)

No. of poles	Coil ratings	Contact ratings	Operations
2, 3	6 to 240 VAC 6 to 125 VDC	5 A, 28 VDC (Resistive) 5 A, 240 VAC (General use)	6 x 10 ³
4		5 A, 240 VAC (General use) (Same polarity) 5 A, 28 VDC (Resistive) (Same polarity)	

CSA C22.2 No. 14 Listings (File No. LR31928)

No. of poles	Coil ratings	Contact ratings	Operations
2, 3	6 to 240 VAC 6 to 125 VDC	5 A, 28 VDC (Resistive) 5 A, 240 VAC (General use)	6 x 10 ³
4		5 A, 240 VAC (General use) (Same polarity) 5 A, 28 VDC (Resistive) (Same polarity)	

SEV Listings (File No. 99.5 50902.01)

No. of poles	Coil ratings	Contact ratings
2, 3, 4	6 to 240 VAC 6 to 125 VDC	5 A, 240 VAC1 5 A, 28 VDC1

LR (No. 563KOB-204524)

No. of poles	Coil ratings	Contact ratings
2	6 to 240 VAC 6 to 120 VDC	2 A, 200 VAC (General use) 2 A, 30 VDC (General use)
4		0.8 A, 200 VAC (General use) 1.5 A, 115 VAC (General use) 1.5 A, 30 VDC (General use)

Engineering Data

Maximum Switching Power

MY2-02, MY2F, MY3 Series

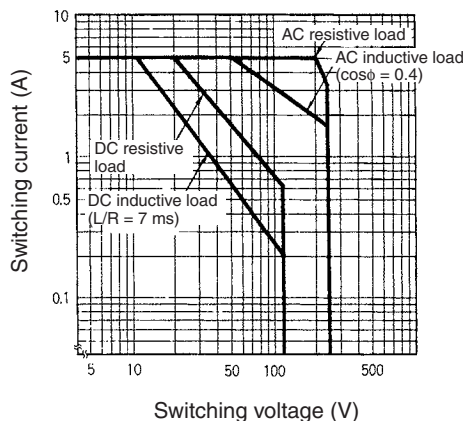

MY4(Z)-02, MY4F, MY4ZF

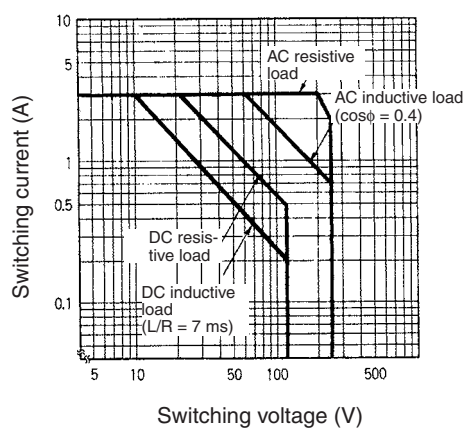

Endurance

MY2-02, MY2F, MY3 Series (Resistive Loads)

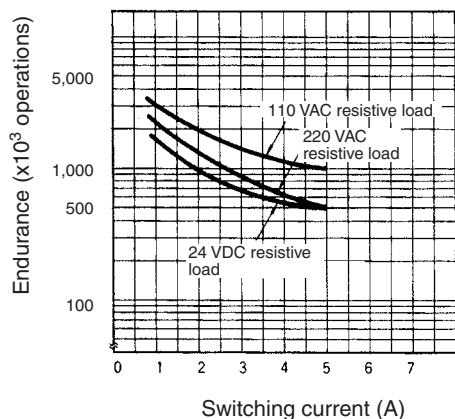

MY2-02, MY2F, MY3 Series (Inductive Loads)

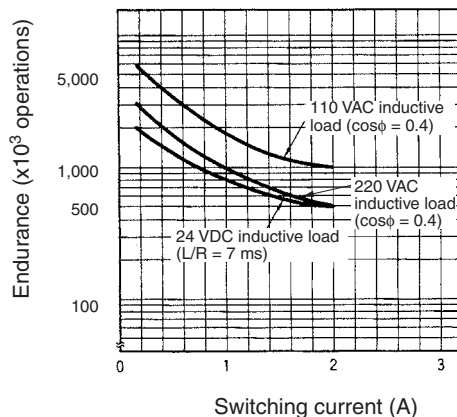

MY4-02, MY4F (Resistive Loads)

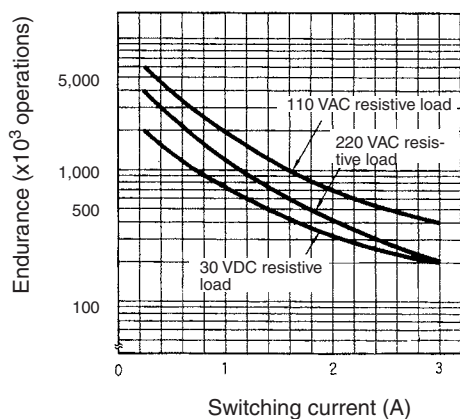

MY4-02, MY4F (Inductive Loads)

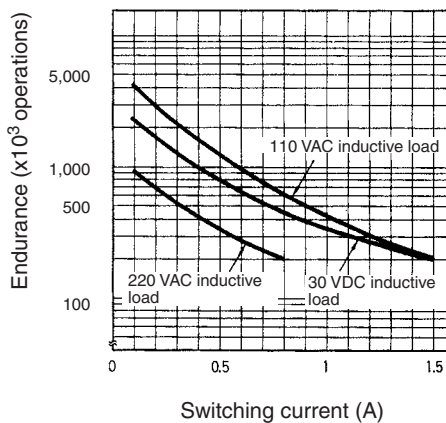

MY4Z-02, MY4ZF (Resistive Loads)

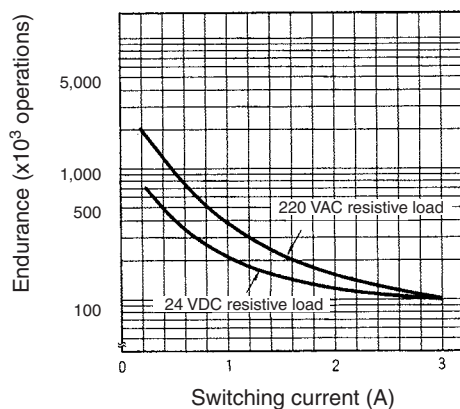

MY4Z-02, MY4ZF (Inductive Loads)

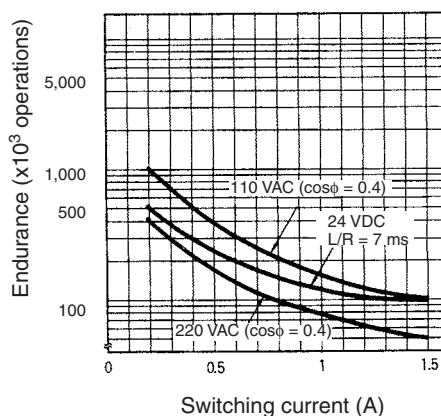

Dimensions

Note: All units are in millimeters unless otherwise indicated.

Relays with Solder Terminals

MY3, MY3N, MY3-D, MY3N-D2

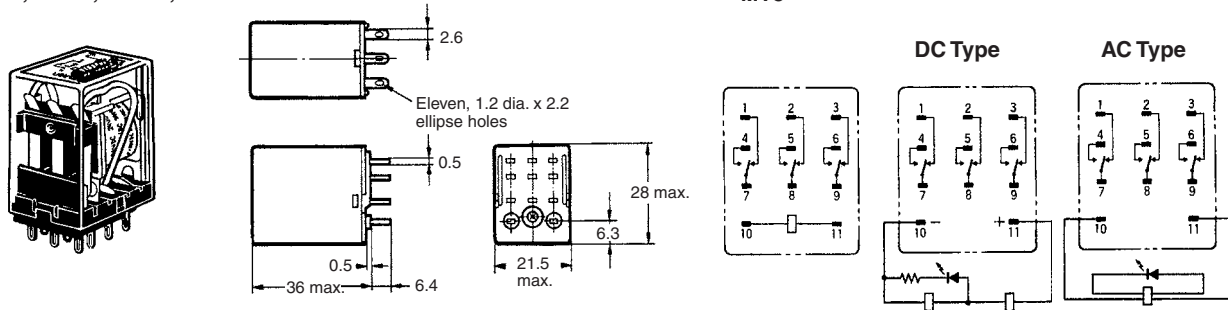

MY3-D

MY3N-D2

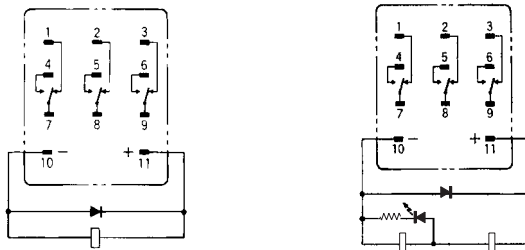

Note: 1. AC type is equipped with a coil disconnection self-diagnostic function.

2. Do not reverse the polarity of DC Relays.

3. The terminal arrangement and internal connections of the above Relays are as same as these of MY□ Relays.

Relays with PCB Terminals

MY□-02

MY4-02 (4PDT)

PC Board Mounting Holes

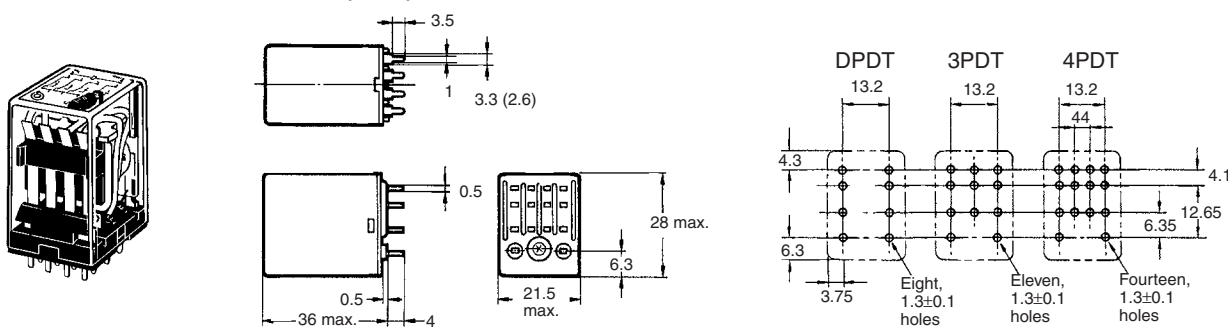

Note: The tolerance is ±0.1.

Note: 1. The figures in the parentheses are for MY4-02.

2. The above dimensions also apply to the DPDT and 3PDT Relays.

3. The internal connections of the above Relays are as same as these of MY□ Relays.

Upper-mounting Relays

MY□F

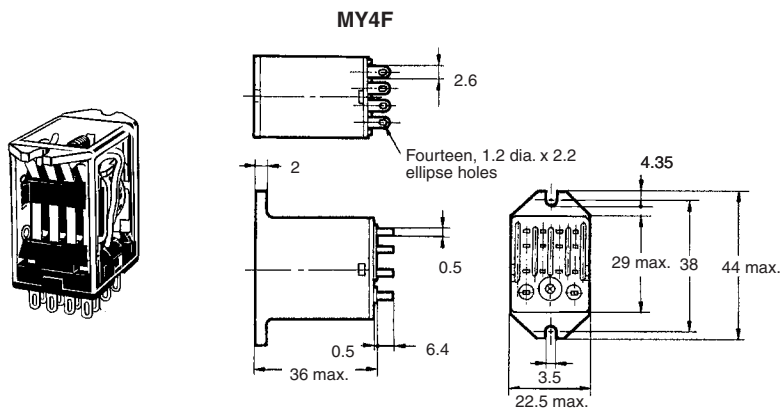

Mounting Holes

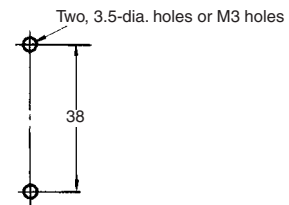

- Note:**
1. The above dimensions also apply to the DPDT, and 3PDT Relays.
 2. The internal connections of the above Relays are as same as these of MY□ Relays.

Mounting Height with Socket

DIN Track/Surface-mounting Socket

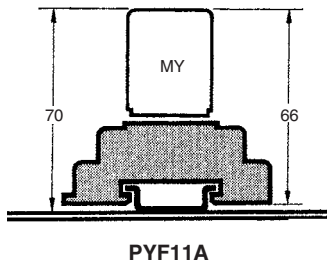

Back-mounting Socket

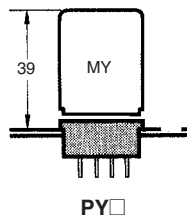

Note: The PYF()A can be track-mounted or screw-mounted.

Sockets

PYF11A

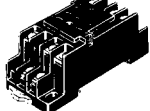

PY11

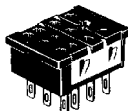

PY11-02

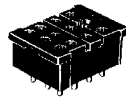

Mounting Plates for Backconnecting Sockets

PYP-1

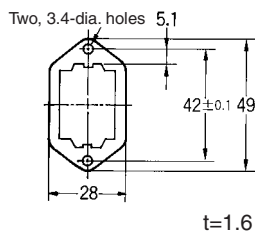

PYP-36

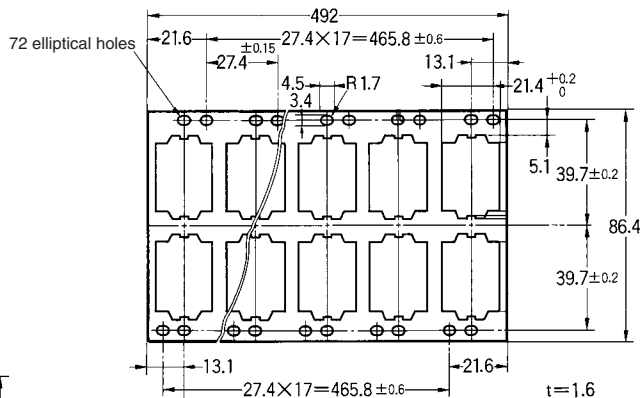

PYP-18

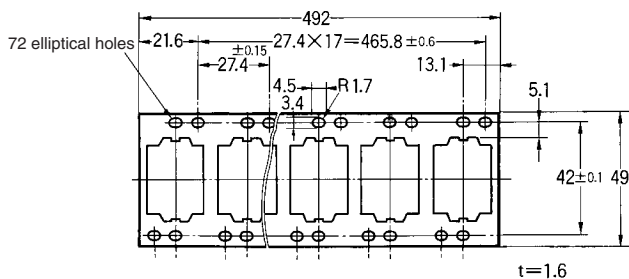

Hold-down Clips

Hold-down clips are used to hold Relays to Sockets and prevent them from coming loose due to vibration or shock.

Connection to Socket		Connection to mounting plate
<p>PYC-A1</p>	<p>PYC-P</p>	<p>PYC-S</p>

■ Safety Standards for Sockets

Item	Standards	File No.
PYF11A	UL508	E87929
	CSA22.2	LR31928

Precautions

Refer to page 11 for general precautions.

■ Connections

Do not reverse polarity when connecting DC-operated Relays with built-in diodes or indicators or high-sensitivity DC-operated Relays.

■ Mounting

- Whenever possible, mount Relays so that it is not subject to vibration or shock in the same direction as that of contact movement.

ALL DIMENSIONS SHOWN ARE IN MILLIMETERS.

To convert millimeters into inches, multiply by 0.03937. To convert grams into ounces, multiply by 0.03527.