

THIS DOCUMENT CONTAINS DATA PROPRIETARY TO PROJECTS UNLIMITED, INC. ANY USE OR REPRODUCTION, IN ANY FORM, WITHOUT PRIOR WRITTEN PERMISSION OF PROJECTS UNLIMITED, INC. IS PROHIBITED.  
© 2003, Projects Unlimited Inc.

SPECIFICATIONS

| PARAMETERS                 | VALUES      | UNITS |
|----------------------------|-------------|-------|
| DIRECTIVITY                | OMNI        | -     |
| SENSITIVITY                | -46±3       | dB    |
| STANDARD OPERATING VOLTAGE | 1.5         | Vdc   |
| MAX OPERATING VOLTAGE      | 10          | Vdc   |
| CURRENT CONSUMPTION MAX    | 0.5         | mA    |
| IMPEDANCE                  | 2.2         | kOhm  |
| SIGNAL TO NOISE RATIO      | 60          | dB    |
| TERMINAL                   | SOLDER PADS | -     |
| INTERNAL CAPACITOR         | N/A         | pF    |

| REVISIONS |                                   |          |          |
|-----------|-----------------------------------|----------|----------|
| LTR       | DESCRIPTION                       | DATE     | APPROVED |
| -         | RELEASED FROM ENGINEERING         | 12/29/03 |          |
| A         | REVISED IMPEDANCE                 | 5/13/04  | R. W.    |
| B         | REVISED DIMENNSION SIZE AND STYLE | 02/15/06 | B. R.    |

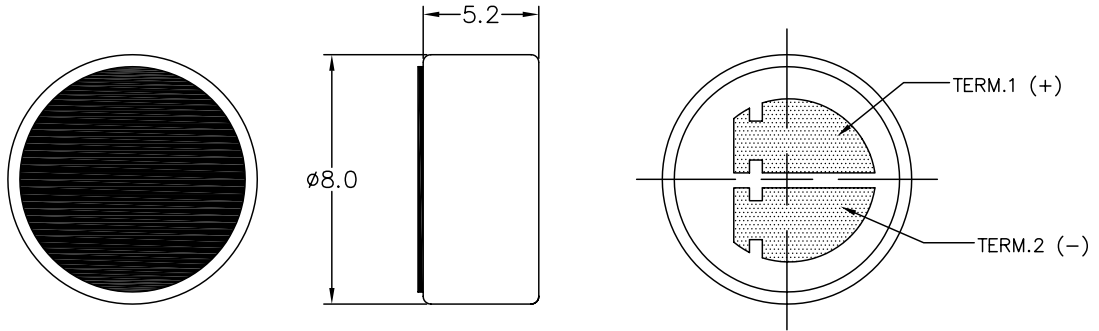

NOTES:

1. ALL DIMENSIONS ARE IN MILLIMETERS.
2. SPECIFICATION SUBJECT TO CHANGE OR WITHDRAWAL WITHOUT NOTICE.

FILE NAME  
DOM-5246L.DWG

| UNLESS OTHERWISE SPECIFIED:<br>DIMENSIONS ARE IN MILLIMETERS, TOLERANCES ARE ±0.5 AND ANGLES ARE ±3°.   |       |  <b>projects® unlimited</b><br>Dayton, Ohio |                          |                       |       |                       |       |            |  |
|---|-------|--|--------------------------|-----------------------|-------|-----------------------|-------|------------|--|
| <table border="1"> <thead> <tr> <th>APPROVALS</th> <th>DATE</th> </tr> </thead> <tbody> <tr> <td>DRAWN <i>R. A. O.</i></td> <td>12/03</td> </tr> <tr> <td>APPROVED <i>E. P.</i></td> <td>12/03</td> </tr> </tbody> </table> |       | APPROVALS  | DATE                     | DRAWN <i>R. A. O.</i> | 12/03 | APPROVED <i>E. P.</i> | 12/03 | MICROPHONE |  |
| APPROVALS   | DATE  |  |                          |                       |       |                       |       |            |  |
| DRAWN <i>R. A. O.</i>   | 12/03 |  |                          |                       |       |                       |       |            |  |
| APPROVED <i>E. P.</i>   | 12/03 |  |                          |                       |       |                       |       |            |  |
| DO NOT SCALE DRAWING  |       | SIZE<br>A  | DRAWING NO.<br>DOM-5246L |                       |       |                       |       |            |  |
|   |       | SCALE: N.T.S.  | SHEET 1 OF 1             |                       |       |                       |       |            |  |