

THIS DOCUMENT IS THE PROPERTY OF
KEYSTONE ELECTRONICS CORP. AND
SHALL NOT BE REPRODUCED, DISTRIBUTED
OR USED AS A BASIS FOR MANUFACTURE
WITHOUT PRIOR WRITTEN PERMISSION
FROM KEYSTONE ELECTRONICS CORP.

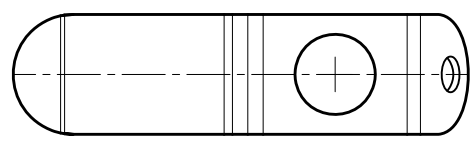

FLAT PATTERN

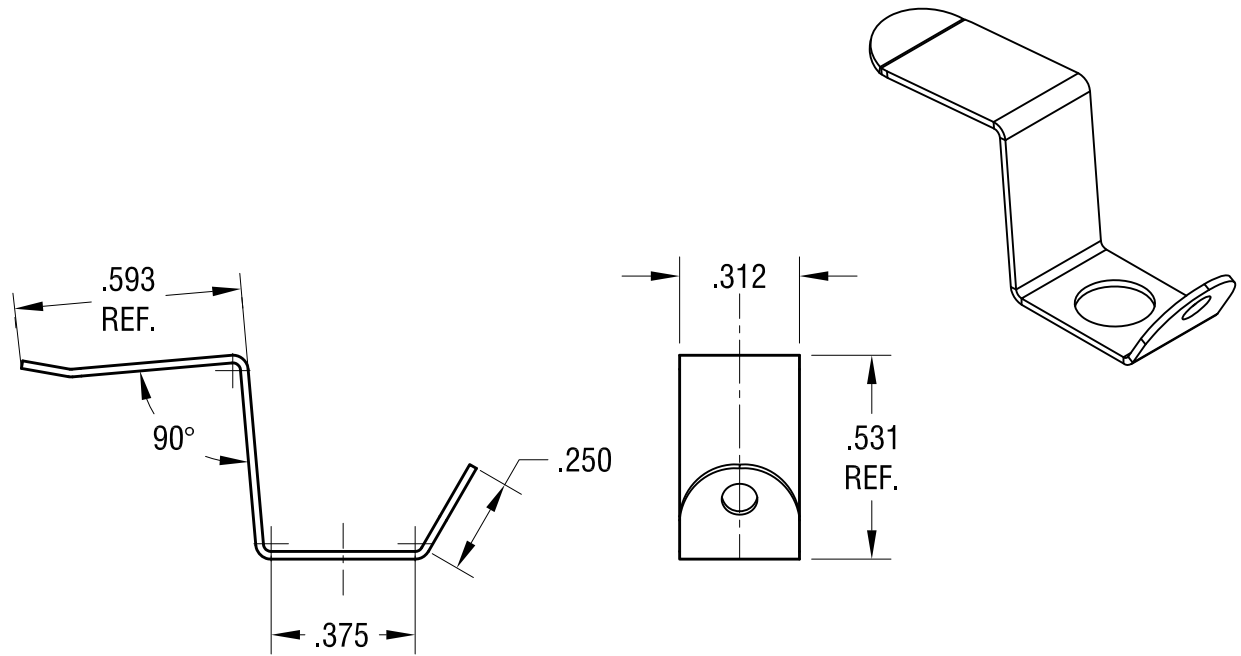
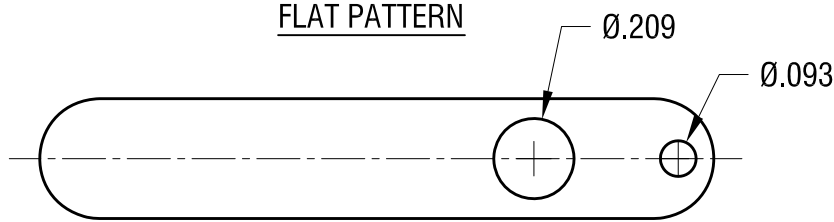

KEYSTONE ELECTRONICS CORP.			
www.keyelco.com • ASTORIA, N.Y. 11105-2017 • Tel (718) 956-8900			
PART NAME		TOP SPRING	
MATERIAL			
.020 [0.50] TH'K PHOSPHOR BRONZE			
FINISH		DRN BY	DATE
NICKEL PLATE		NT	9.15.10
		APP'D	SCALE
			2X
TOLERANCES	INCH	[MM]	CODE
DECIMAL	± .010	[± 0.25]	C
ANGULAR	± 1°		
UNLESS OTHERWISE SPECIFIED			
DWG NO.		113	

DATE	DESCRIPTION	REV.
------	-------------	------