

Figure 1

1. INTRODUCTION

This instruction sheet covers the use and maintenance of AMP Crimping Die Assemblies 543424-1 through -8, which are designed to be used in AMP Hand Crimping Tool Frame Assembly 543344-1 or 58235-1, or in AMP Pneumatic Power Unit 312522-3 equipped with Die Holder Assembly 58449-1. Each die assembly crimps a ferrule onto round shielded cable used with AMP Shielded AMPLIMITE Connectors.

AMP Catalog 82068 provides a guide for cable-to-connector and ferrule selection. Read these and all referenced materials before using the die assemblies.

NOTE

Measurements are in millimeters [followed by inches in brackets]. Figures are not drawn to scale.

Reasons for reissue are provided in Section 7, REVISION SUMMARY.

2. DESCRIPTION

Each die assembly consists of an indenter (stationary die) and an anvil (moving die). When mated, the dies form two crimping sections: the braid and the insulation. The braid section crimps the front part of the ferrule onto the cable shield and the cable outlet of the connector shield assembly, and simultaneously, the insulation section crimps the back part of the ferrule onto the cable insulation. The anvil die is

designed with a stop to ensure proper positioning of the ferrule for crimping. See Figure 1.

The ferrule, which is ordered separately from the AMPLIMITE connector, is sized according to the insulation diameter of the cable. Each die assembly is marked with the cable insulation diameter range.

3. DIE ASSEMBLY INSTALLATION

The die assembly is designed to fit securely into the tool by upper and lower die holder plates; each die is held in by a single screw. To install the die assembly, refer to the instructions packaged with the tool:

408-9315	AMP Hand Crimping Tool Frame Assembly 543344-1
408-9245	AMP Hand Crimping Tool Frame Assembly 58235-1
408-9721	AMP Die Holder Assembly 58449-1
409-5822	AMP Pneumatic Power Unit 312522-3

4. CRIMPING PROCEDURE

Assemble the connector by referring to instruction sheet 408-9010. Make sure the ferrule is over the connector shield cable outlet and butted against the shield body. Then, proceed as follows:

1. Place the ferrule on the moving die, with the cable extending out the back side of the die. Make sure that the front part of the ferrule is positioned in the braid section and the back part of the ferrule is positioned in the insulation section. See Figure 2.

CAUTION

The front edge of the ferrule must be against the stop and the connector body must be clear of the dies.

2. Actuate tool for crimping according to the instructions packaged with the tool.
3. Remove connector from die assembly and inspect the crimped ferrule to the requirements outlined in the applicable application specification:

114-40006	AMPLIMITE Connector HDE-20 Fully Shielded
114-40030	AMPLIMITE Connector HDP-20 Fully Shielded
114-40008	AMPLIMITE Enclosure Kit HDE-20 Shielding Hardware
114-40009	AMPLIMITE Enclosure Kit HDP-20 Shielding Hardware

See Figure 3 for a properly crimped ferrule.

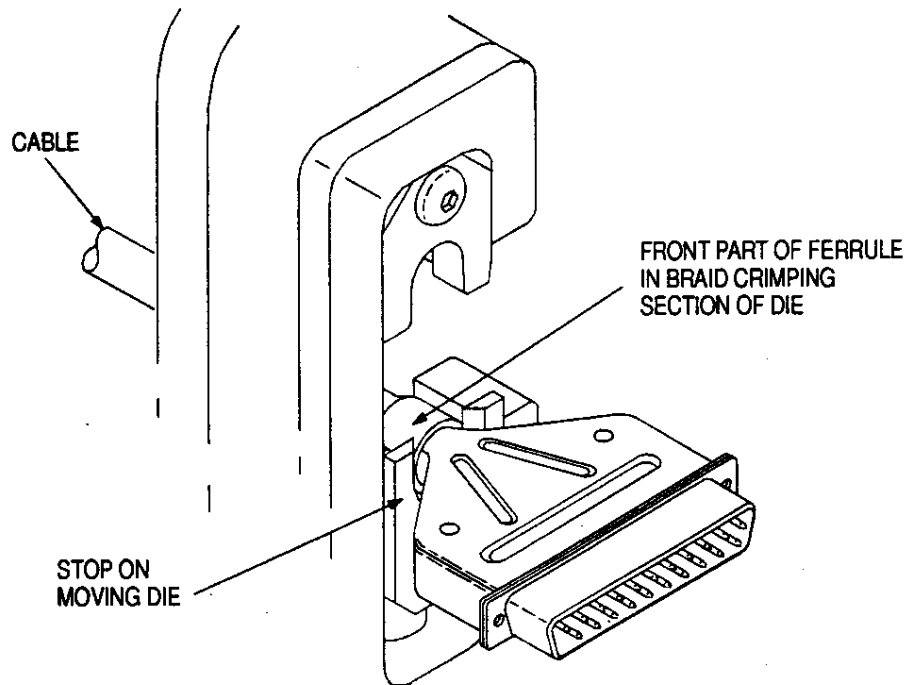

Figure 2

5. MAINTENANCE AND INSPECTION PROCEDURE

The die assembly is inspected prior to shipment, however, AMP recommends that the die assembly be inspected immediately upon arrival. AMP recommends that a maintenance and inspection program be performed periodically to ensure continued reliability of the die assembly. The inspection frequency should be based on the amount of use, working conditions, operator training and skill, and established company standards.

5.1. Daily Maintenance

1. Remove accumulated dust, moisture, and other contaminants with a clean, soft brush or lint-free cloth. Do NOT use hard or abrasive objects that could damage the dies.

2. Make sure dies are protected with a THIN coat of any good SAE No. 20 motor oil. Do NOT oil excessively.

3. When die assembly is not in use, mate and store them in a clean, dry area.

5.2. Periodic Inspection

A. Visual Inspection

1. Remove all lubrication and accumulated film from the dies by immersing the dies in a suitable commercial degreaser that will not affect paint or plastic material.
2. Make sure that all die retention screws and die components are properly secured.
3. Inspect die assembly for worn, cracked, or broken surfaces. If damage is evident, the dies must be replaced. See Section 6, REPLACEMENT PARTS.

B. Gaging the Crimping Section

This inspection requires the use of a plug gage conforming to the dimensions provided in Figure 4. AMP does not manufacture or market these gages. To gage the crimping section, remove die assembly from tool and proceed as follows:

1. Remove traces of oil or dirt from the crimping section and plug gage.
2. Mate the dies until the crimping surfaces have bottomed; then hold in this position. DO NOT force the dies beyond initial contact.

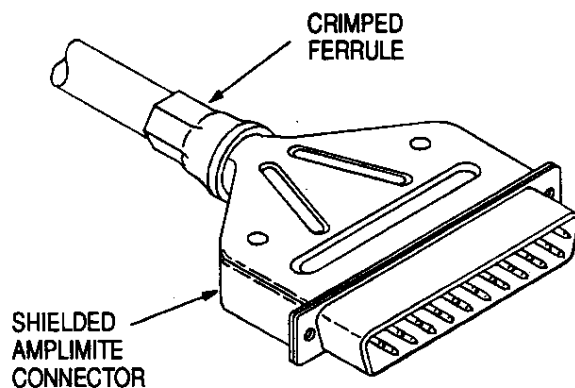
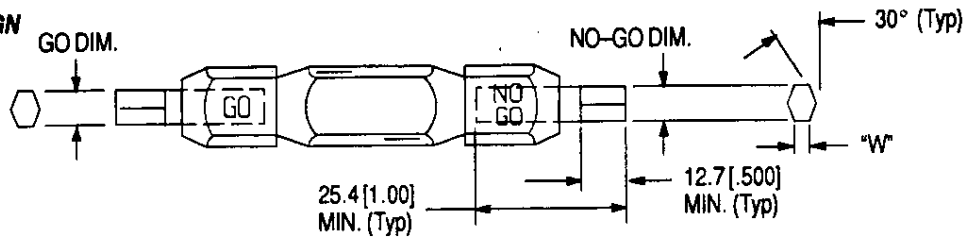

Figure 3

SUGGESTED PLUG GAGE DESIGN FOR INSULATION CRIMPING SECTION



DIE ASSEMBLY PART NUMBER	GAGE ELEMENT DIMENSIONS		
	GO	NO-GO	WIDTH (Max) "W"
543424-1	6.477 - 6.485 [.2550 - .2553]	6.325 - 6.731 [.2649 - .2650]	3.61 [.142]
543424-2	5.207 - 5.215 [.2050 - .2053]	5.458 - 5.461 [.2149 - .2150]	2.87 [.113]
543424-3	4.293 - 4.300 [.1690 - .1693]	4.544 - 4.547 [.1789 - .1790]	2.87 [.113]
543424-4	10.287 - 10.295 [.4050 - .4053]	10.538 - 10.541 [.4149 - .4150]	5.82 [.229]
543424-5	9.779 - 9.787 [.3850 - .3853]	10.030 - 10.033 [.3949 - .3950]	5.26 [.207]
543424-6	8.458 - 8.466 [.3330 - .3333]	8.710 - 8.712 [.3429 - .3430]	4.75 [.187]
543424-7	7.442 - 7.450 [.2930 - .2933]	7.693 - 7.696 [.3029 - .3030]	4.16 [.164]
543424-8	5.867 - 5.875 [.2310 - .2313]	6.119 - 6.121 [.2409 - .2410]	3.30 [.130]

SUGGESTED PLUG GAGE DESIGN FOR BRAID CRIMPING SECTION

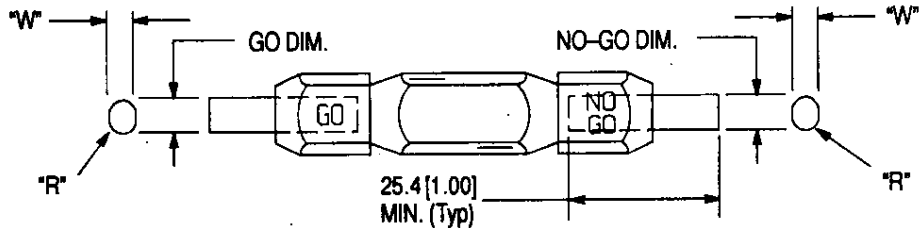

DIE ASSEMBLY PART NUMBER	GAGE ELEMENT DIMENSIONS			
	GO	NO-GO	WIDTH (Max) "W"	RADIUS (Max) "R"
543424-1 through -8	10.719 - 10.726 [.4220 - .4223]	10.919 - 10.922 [.4299 - .4300]	10.67 [.420]	5.36 [.211]

Figure 4

NOTE Pivot the stop away from the moving die in order to gage the braid crimping section.

3. Carefully insert GO element into the corresponding crimping section; do not force it. The GO element must pass completely through the crimping section.

4. In the same manner, try to insert the NO-GO element into the same crimping section. The NO-GO element may start entry, but must not pass completely through the crimping section.

If the crimping sections conform to the gage inspection, they are considered dimensionally correct, and should be lubricated with a THIN coat of any good SAE No. 20 motor oil. If not, the die assembly must be replaced. Refer to Section 6, REPLACEMENT PARTS.

For additional information concerning the use of a plug gage, refer to instruction sheet 408-7424.

6. REPLACEMENT PARTS

The parts listed in Figure 5 are customer-replaceable. A complete inventory can be stocked and controlled to prevent lost time when replacement of parts is necessary. Parts other than those listed should be replaced by AMP to ensure quality and reliability of the die assembly.

Order replacement parts through your AMP representative, or call 1-800-526-5142, or send a facsimile of your purchase order to 717-986-7605, or write to:

CUSTOMER SERVICE (38-35)
AMP INCORPORATED
P.O. BOX 3608
HARRISBURG, PA 17105-3608

7. REVISION SUMMARY

Revisions to this document include:

Per EC M-3143:

- Added Pneumatic Power Unit 312522-3 and reference material 409-5822
- Added Die Holder Assembly 58449-1 and reference material 408-9721
- Added Hand Crimping Tool Frame Assembly 58235-1 and reference material 408-9245

- Added replacement parts list
- Added die closure dimensions for braid section
- Added gage member dimensions, illustration of plug gage design, and gaging procedure

Per EC 0990-0252-93:

- New format
- Added metric dimensions
- Application Specification 114-40007 was superseded by 114-40030

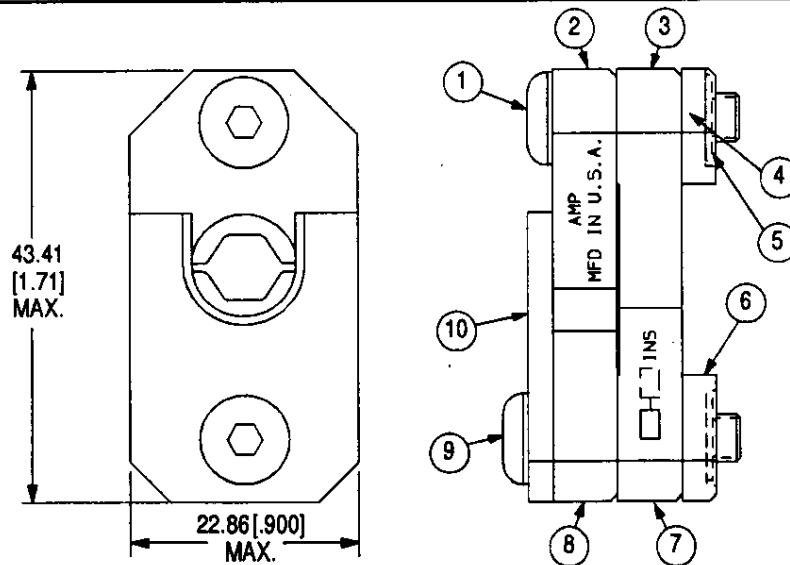

DIE ASSEMBLY PART NUMBER	REPLACEMENT PARTS			
	ITEM	PART NUMBER	DESCRIPTION	QUANTITY
543424-1 through 543424-8	1	543416-1	SCREW, Special	1
	2	543417-1	INDENTER, Braid	1
543424-1 through 543424-8	3	543402-1	INSERT, Insulation, Upper	1
		543415-1		
		543410-1		
		543406-1		
		543423-1		
		543421-2		
		543399-1		
		543408-1		
543424-1 through 543424-8	4	543411-1	SPACER, Upper	1
	5	1-21046-3	RING, Retaining, External E-Ring	2
	6	543412-1	SPACER, Lower	1
543424-1 through 543424-8	7	543401-1	INSERT, Insulation, Lower	1
		543414-1		
		543409-1		
		543405-1		
		543422-1		
		543420-2		
		543400-1		
		543407-1		
543424-1 through 543424-8	8	543418-1	ANVIL, Braid	1
	9	543416-2	SCREW, Special	1
	10	543413-1	STOP, Ferrule	1

Figure 5