

THIS DOCUMENT IS THE PROPERTY OF KEYSTONE ELECTRONICS CORP. AND SHALL NOT BE REPRODUCED, DISTRIBUTED OR USED AS A BASIS FOR MANUFACTURE WITHOUT PRIOR WRITTEN PERMISSION FROM KEYSTONE ELECTRONICS CORP.

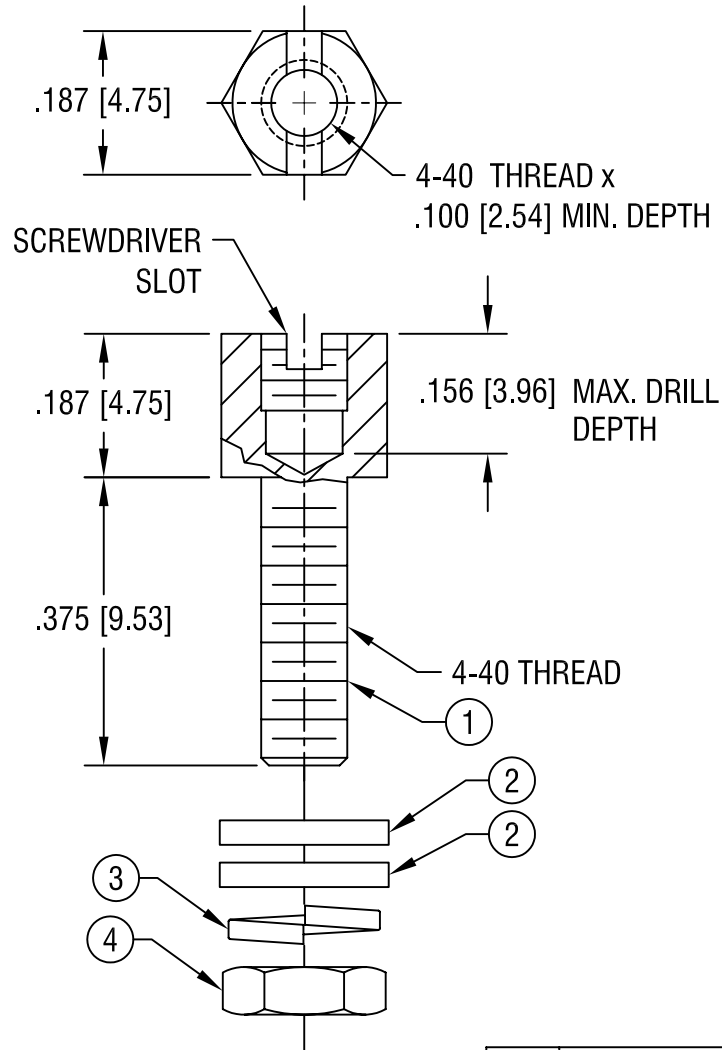

**NOTE:**

1. FINISH: ZINC PLATE, TRIVALENT AND YELLOW DIE.

NO.	PART NO.	DESCRIPTION	QTY
1	7272	JACK SCREW	1
2	7230-1	FLAT WASHER	2
3	7230-2	LOCKWASHER	1
4	7230-3	NUT	1

**KEYSTONE ELECTRONICS CORP.**

ASTORIA, N.Y. 11105-2017

PART NAME			
JACK SCREW W/ SLOT & HARDWARE			
MATERIAL			
STEEL			
FINISH		DRN BY	DATE
AS NOTED		BOONE	3.10.06
		APP'D	SCALE
			4X
TOLERANCES	INCH [MM]	CODE	DWG NO.
DECIMAL	± .005 [± 0.15]	C/M	7292
ANGULAR	± 1°		
UNLESS OTHERWISE SPECIFIED			

DATE	DESCRIPTION	REV.