

REV.	DESCRIPTION	DATE	APPROVED
A	Engineering Update w/o Changes	02/20/04	M. C.

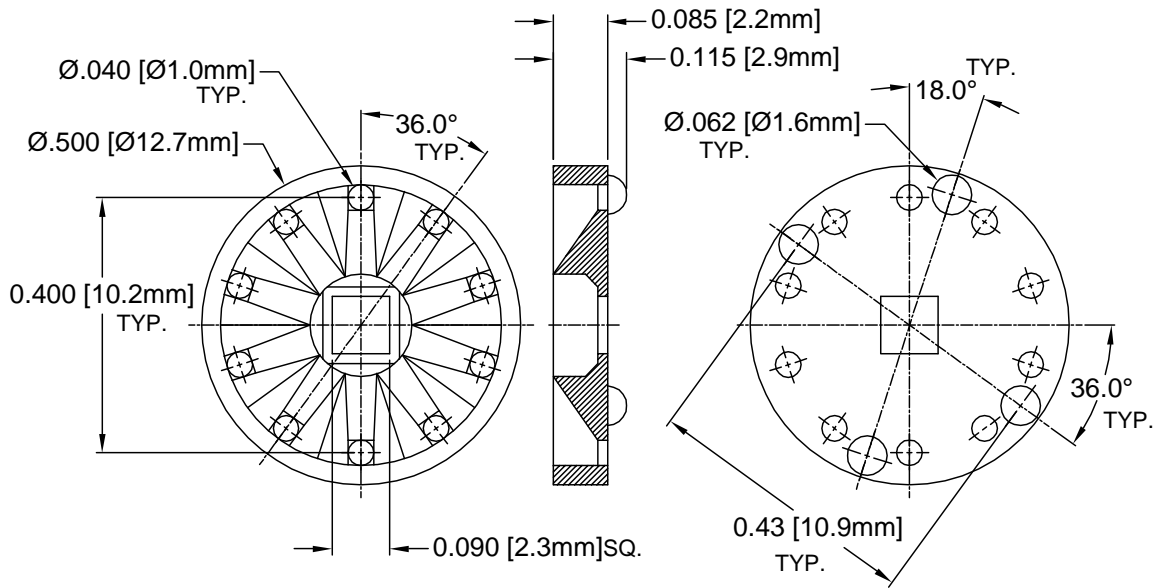

2. MATERIAL: NYLON 6/6, 94V-2, NATURAL. BIVAR MATERIAL CODE 03-NL.  
 BASF ULTRAMID NYLON 6/6 A3K NATURAL.
1. GENERAL SPECIFICATIONS: BIVAR MOLDED COMPONENT SPECIFICATION BV00-E101.

STANDARD TOLERANCE (UNLESS OTHERWISE SPECIFIED)		BIVAR®	
DECIMALS	ANGULAR	4 THOMAS, IRVINE, CA. 92618 TEL: (949) 951-8808 FAX: (949) 951-3974	
.X ± .1	X° ± 1°	TITLE: PERM-O-PAD IC MOUNT	
.XX ± .01		DESIGNED: <b>Sam Dagher</b>	DATE: <b>02/26/93</b>
.XXX ± .005		CHECKED: <b>E. Muldoon</b>	DATE: <b>02/26/93</b>
		PART NO: <b>701-130</b>	REVISION: <b>A</b>
		CAGE CODE: <b>32559</b>	SHEET # <b>1 OF 1</b>
CAD GENERATED DOCUMENT. DO NOT MEASURE DRAWING.			