

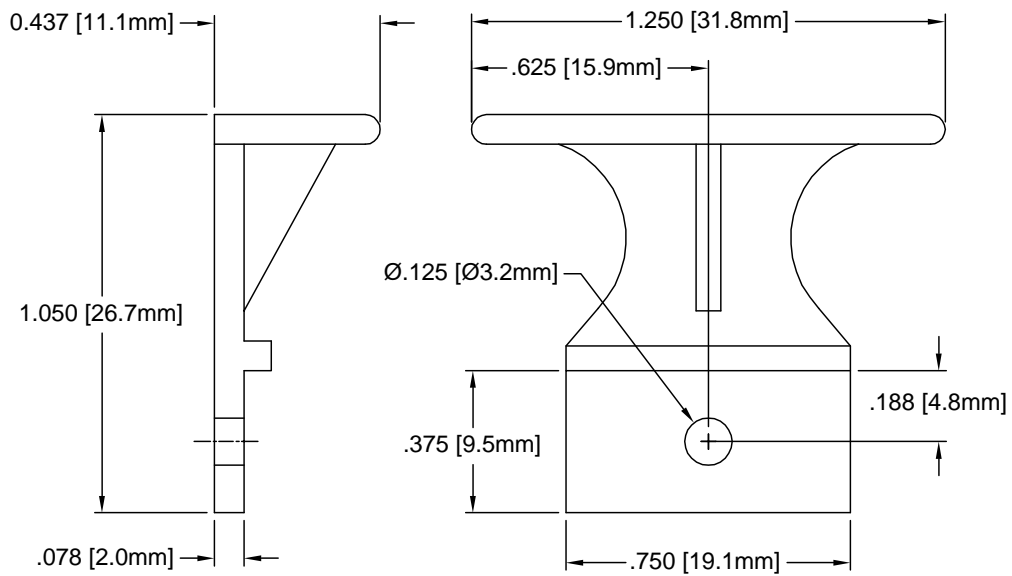

REV.	DESCRIPTION	DATE	APPROVED
B	Engineering Update w/o Changes	02/24/04	M. C.



3. MATERIAL: NYLON 6/6, 94V-2, NATURAL. BIVAR MATERIAL CODE 03-NL.
BASF ULTRAMID NYLON 6/6 A3K NATURAL.
2. MATERIAL: NYLON 6/6, 94V-2, WHITE. BIVAR MATERIAL CODE 04-WE.
BASF ULTRAMID NYLON 6/6 A3K WHITE.
1. GENERAL SPECIFICATIONS: BIVAR MOLDED COMPONENT SPECIFICATION BV00-E101.

STANDARD TOLERANCE (UNLESS OTHERWISE SPECIFIED)		 4 THOMAS, IRVINE, CA. 92618 TEL: (949) 951-8808 FAX: (949) 951-3974		
DECIMALS	ANGULAR			
.X ± .1	X° ± 1°	TITLE: CIRCUIT BOARD CARD EJECTOR		
.XX ± .01				
.XXX ± .005			PART NO: CP-00	REVISION: B
DESIGNED: Shane Irving	DATE: 02/23/99	CAGE CODE : 32559		SHEET # 1 OF 1
CHECKED: D. Green	DATE: 02/24/04	CAD GENERATED DOCUMENT. DO NOT MEASURE DRAWING.		