

REV.	DESCRIPTION	DATE	APPROVED
C	Engineering Release.	11/30/04	M. C.

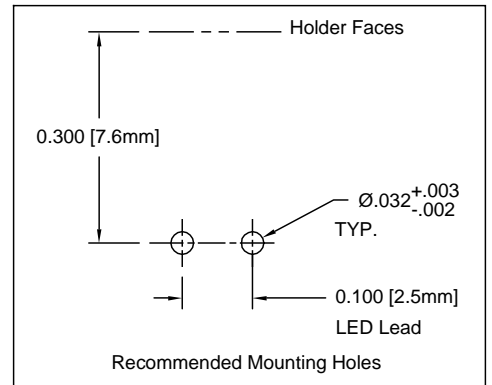
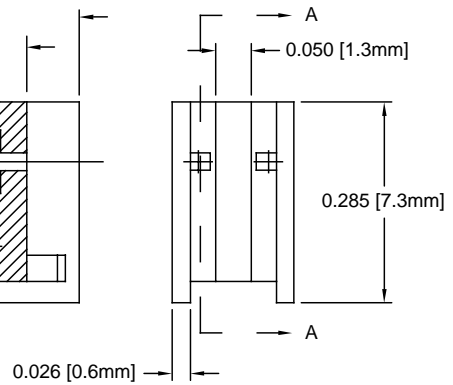
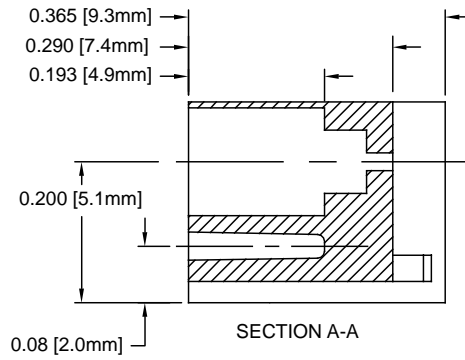
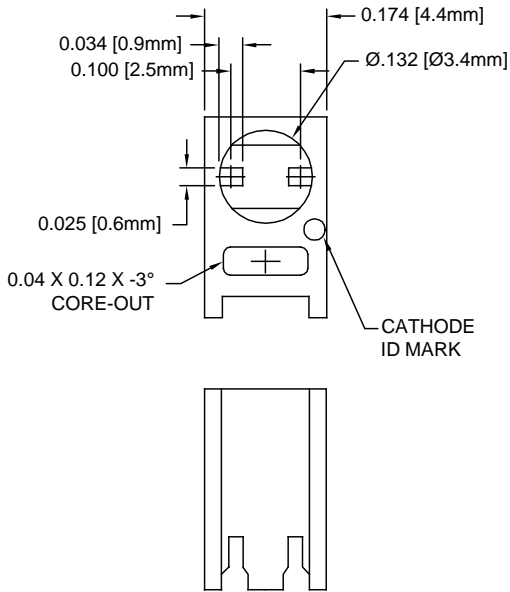

2. MATERIAL: NYLON 6/6, 94V-0, BLACK. BIVAR MATERIAL CODE 22-BK.
RTP POLYAMIDE NYLON 6/6, 0200 FR, BLACK OR MODIFIED PLASTICS MN6/6-SE BK.
1. GENERAL SPECIFICATIONS: BIVAR MOLDED COMPONENT SPECIFICATION BV00-E101.

STANDARD TOLERANCE (UNLESS OTHERWISE SPECIFIED)		BIVAR®	
DECIMALS	ANGULAR	4 THOMAS, IRVINE, CA. 92618	
.X ± .1	X° ± 1°	TEL: (949) 951-8808 FAX: (949) 951-3974	
.XX ± .01		TITLE: T-1 (3mm) LED HOLDER, 90° MOUNT, INTERLOCKING VARIABLE DIAMETER	
.XXX ± .005		DESIGNED: Michael Chen	DATE: 04/16/03
		CHECKED: D. Green	DATE: 04/16/03
		PART NO: H-101C-EL	REVISION: C
		CAGE CODE: 32559	SHEET # 1 OF 1
		CAD GENERATED DOCUMENT. DO NOT MEASURE DRAWING.	