

REV.	DESCRIPTION	DATE	APPROVED
A	Engineering Release for Round Lead Version.	02/27/04	M. C.

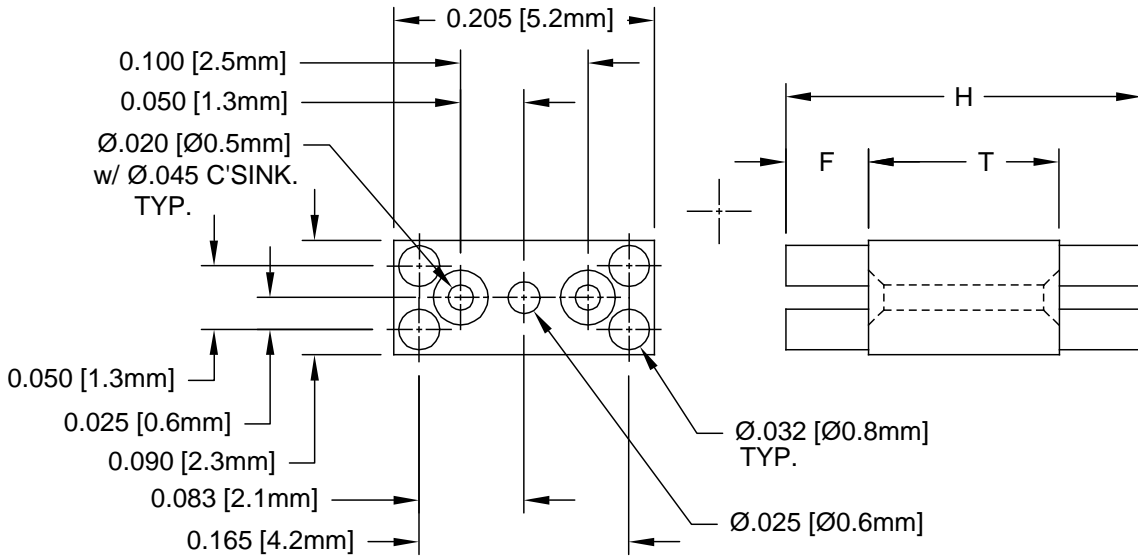

PART NUMBER	H	T	F
RL1-120-020	.120 (3.0mm)	0.040 (1.0mm)	0.040 (1.0mm)
RL1-150-020	.150 (3.8mm)		0.055 (1.4mm)

PART NUMBER	H	T	F
RL2-280-020	0.280 (7.1mm)	0.150 (3.8mm)	0.065 (1.7mm)

STANDARD TOLERANCE (UNLESS OTHERWISE SPECIFIED)		BIVAR®	
DECIMALS	ANGULAR	4 THOMAS, IRVINE, CA. 92618 TEL: (949) 951-8808 FAX: (949) 951-3974	
.X ± .1	X° ± 1°	TITLE: MOLDED RECTANGULAR LED MOUNT, ROUND LEAD	
.XX ± .01		DESIGNED: <b>Michael Chen</b>	DATE: <b>03/11/03</b>
.XXX ± .005		CHECKED: <b>D. Green</b>	DATE: <b>03/11/03</b>
		PART NO: <b>RL1 / RL2-XXX-020</b>	REVISION: <b>A</b>
		CAGE CODE : <b>32559</b>	SHEET # <b>1 OF 1</b>
		CAD GENERATED DOCUMENT. DO NOT MEASURE DRAWING.	

2. MATERIAL: NYLON 6/6, 94V-0, NATURAL/WHITE. BIVAR MATERIAL CODE 24-WE.  
RTP POLYAMIDE NYLON 6/6, 0299X63548, NATURAL OR MODIFIED PLASTICS MN6/6-SE WHT.
1. GENERAL SPECIFICATIONS: BIVAR MOLDED COMPONENT SPECIFICATION BV00-E101.