

THIS DOCUMENT IS THE PROPERTY OF
KEYSTONE ELECTRONICS CORP. AND
SHALL NOT BE REPRODUCED, DISTRIBUTED
OR USED AS A BASIS FOR MANUFACTURE
WITHOUT PRIOR WRITTEN PERMISSION
FROM KEYSTONE ELECTRONICS CORP.

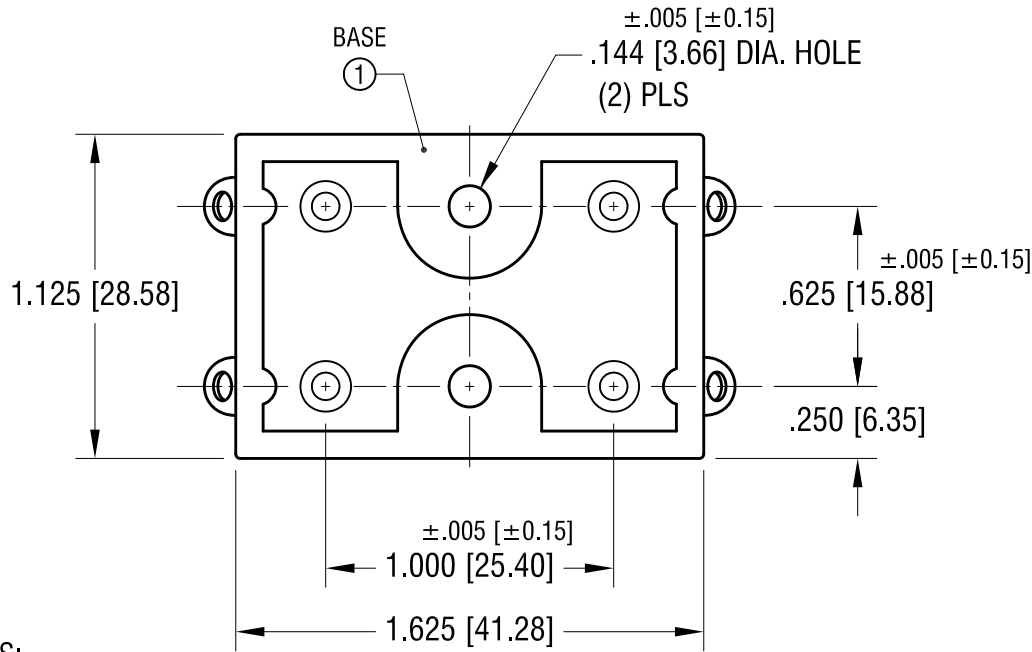
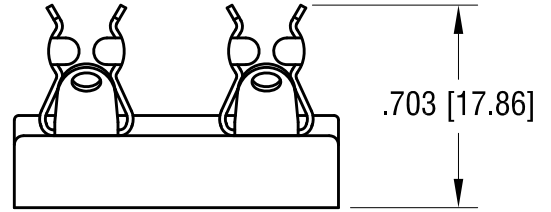
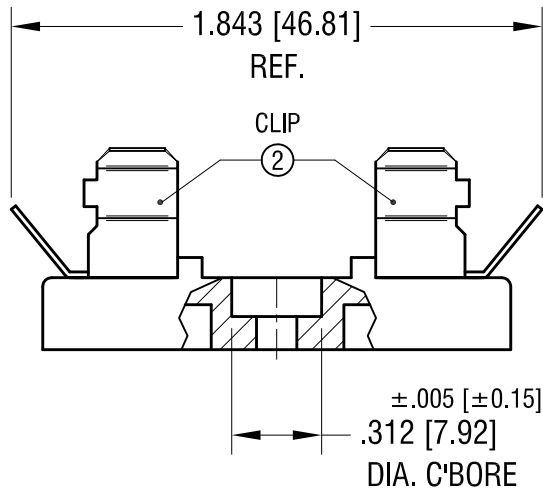

NOTES:

- ① BASE:
MAT'L: .250 [6.35] TH'K
MOLDED PLASTIC, FLAME RETARDANT,
UL 94V-0
- ② CLIP: P/N 3535

KEYSTONE ELECTRONICS CORP.			
ASTORIA, N.Y. 11105-2017			
PART NAME		MOLDED 3AG FUSE HOLDER	
MATERIAL AS NOTED			
FINISH AS NOTED		DRN BY BOONE	DATE 10.11.96
		APP'D	SCALE 1.5X
TOLERANCES	INCH [MM]	CODE	DWG NO.
DECIMAL	± .015 [± 0.38]	C/M	3524
ANGULAR	± 1°		
UNLESS OTHERWISE SPECIFIED			

3.29.10	CHANGE AS PER ECN 10-027	A
DATE	DESCRIPTION	REV.