

THIS DOCUMENT IS THE PROPERTY OF
KEYSTONE ELECTRONICS CORP. AND
SHALL NOT BE REPRODUCED, DISTRIBUTED
OR USED AS A BASIS FOR MANUFACTURE
WITHOUT PRIOR WRITTEN PERMISSION
FROM KEYSTONE ELECTRONICS CORP.

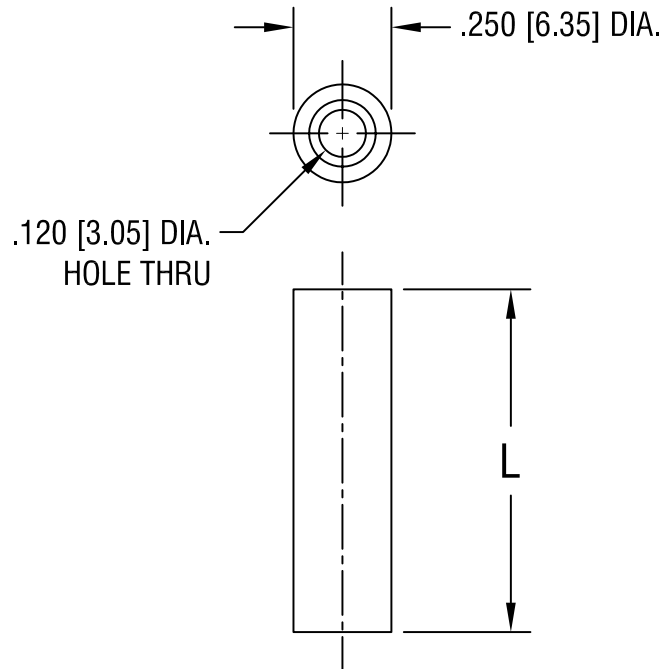

| PART NO. | 'L' DIM. |
|----------|---------------|
| 1924 | 1.500 [38.10] |
| 1925 | 2.000 [50.80] |

| KEYSTONE ELECTRONICS CORP. | | | |
|-------------------------------------|---------------------------|-----------------|------------------|
| ASTORIA, N.Y. 11105-2017 | | | |
| PART NAME CLEAR THRU-HOLE SPACER | | | |
| MATERIAL BRASS | | | |
| FINISH NICKEL PLATE | | DRN BY BOONE | DATE 11.25.96 |
| | | APP'D | SCALE 2X |
| TOLERANCES | INCH [MM] | CODE | DWG NO. |
| DECIMAL | $\pm .005$ [± 0.15] | C/M | 1924-1925 |
| ANGULAR | $\pm 1^\circ$ | | |
| UNLESS OTHERWISE SPECIFIED | | | |

| DATE | DESCRIPTION | REV. |
|------|-------------|------|
| | | |