

THIS DOCUMENT IS THE PROPERTY OF KEYSTONE ELECTRONICS CORP. AND SHALL NOT BE REPRODUCED, DISTRIBUTED OR USED AS A BASIS FOR MANUFACTURE WITHOUT PRIOR WRITTEN PERMISSION FROM KEYSTONE ELECTRONICS CORP.

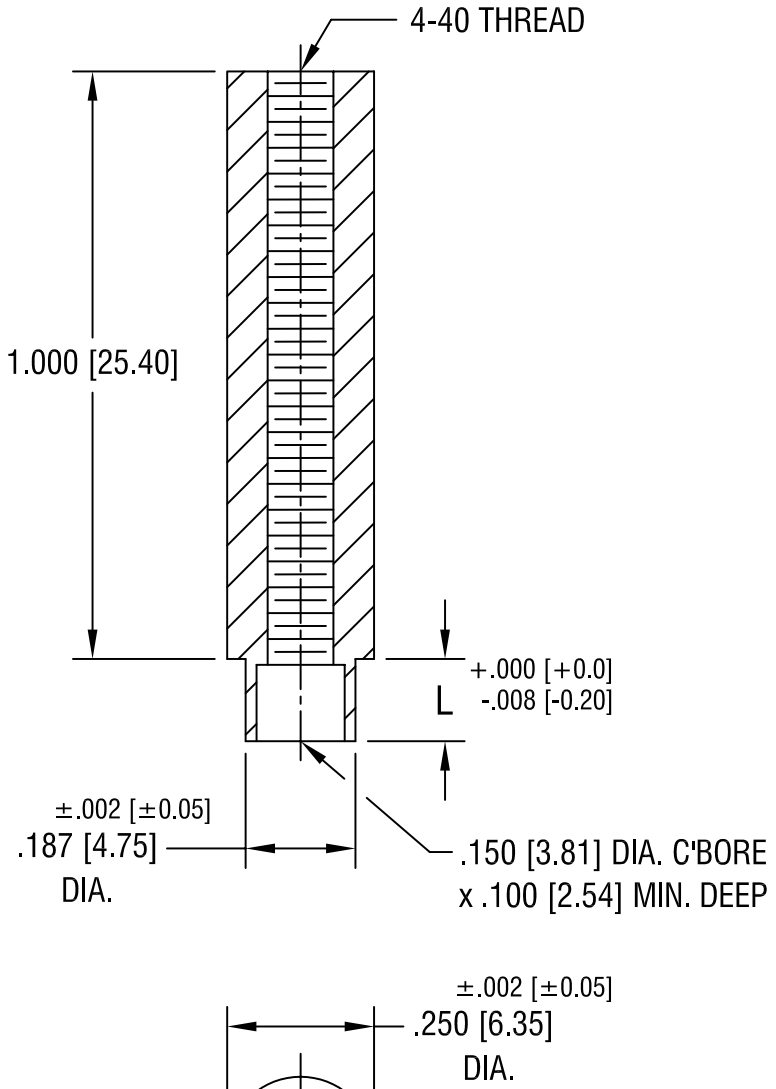

PART NO.	'L' DIM.
1652-2	.109 [2.77]
1652-3	.140 [3.56]

KEYSTONE ELECTRONICS CORP.			
ASTORIA, N.Y. 11105-2017			
PART NAME SWAGE THREADED STANDOFF			
MATERIAL BRASS			
FINISH DUCTILE NICKEL PLATE	DRN BY BOONE	DATE 11.21.96	
	APP'D	SCALE 3X	
TOLERANCES INCH [MM] DECIMAL ± .005 [± 0.15] ANGULAR ± 1° UNLESS OTHERWISE SPECIFIED	CODE C/M	DWG NO. 1652-	

1.17.02	CHANGE AS PER ECN 02-006	A
DATE	DESCRIPTION	REV.