

THIS DOCUMENT IS THE PROPERTY OF
KEYSTONE ELECTRONICS CORP. AND
SHALL NOT BE REPRODUCED, DISTRIBUTED
OR USED AS A BASIS FOR MANUFACTURE
WITHOUT PRIOR WRITTEN PERMISSION
FROM KEYSTONE ELECTRONICS CORP.

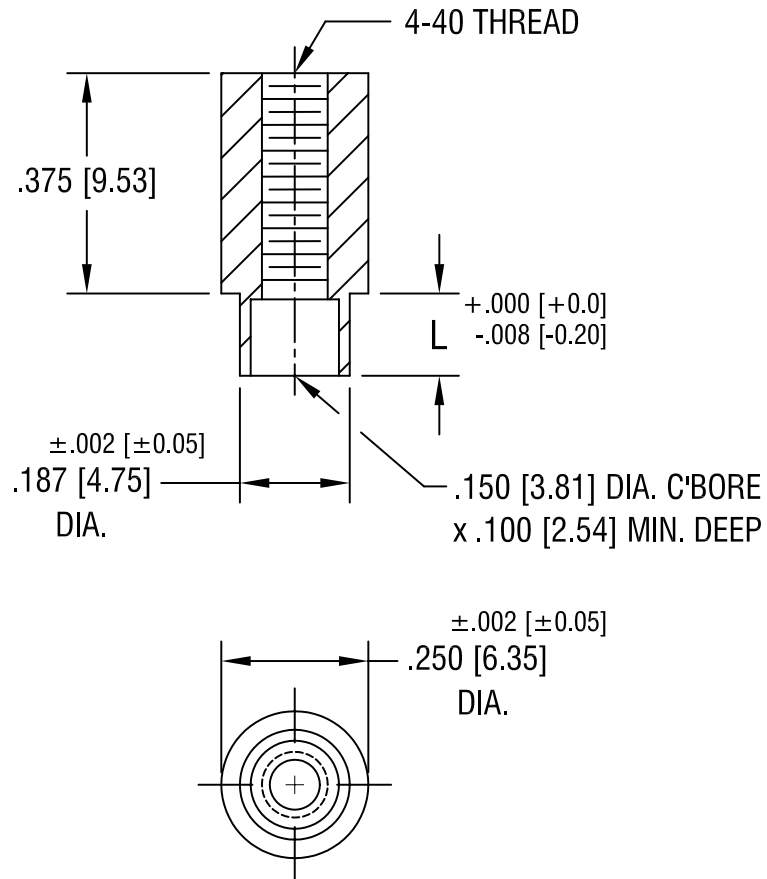

PART NO.	'L' DIM.
1651-2	.109 [2.77]
1651-3	.140 [3.56]

KEYSTONE ELECTRONICS CORP.			
ASTORIA, N.Y. 11105-2017			
PART NAME SWAGE THREADED STANDOFF			
MATERIAL BRASS			
FINISH DUCTILE NICKEL PLATE	DRN BY	BOONE	DATE 5.13.02
	APP'D		SCALE 3X
TOLERANCES	INCH	[MM]	CODE
DECIMAL	± .005	[± 0.15]	C/M
ANGULAR	± 1°		
UNLESS OTHERWISE SPECIFIED			DWG NO. 1651-

DATE	DESCRIPTION	REV.