

THIS DOCUMENT IS THE PROPERTY OF  
KEYSTONE ELECTRONICS CORP. AND  
SHALL NOT BE REPRODUCED, DISTRIBUTED  
OR USED AS A BASIS FOR MANUFACTURE  
WITHOUT PRIOR WRITTEN PERMISSION  
FROM KEYSTONE ELECTRONICS CORP.

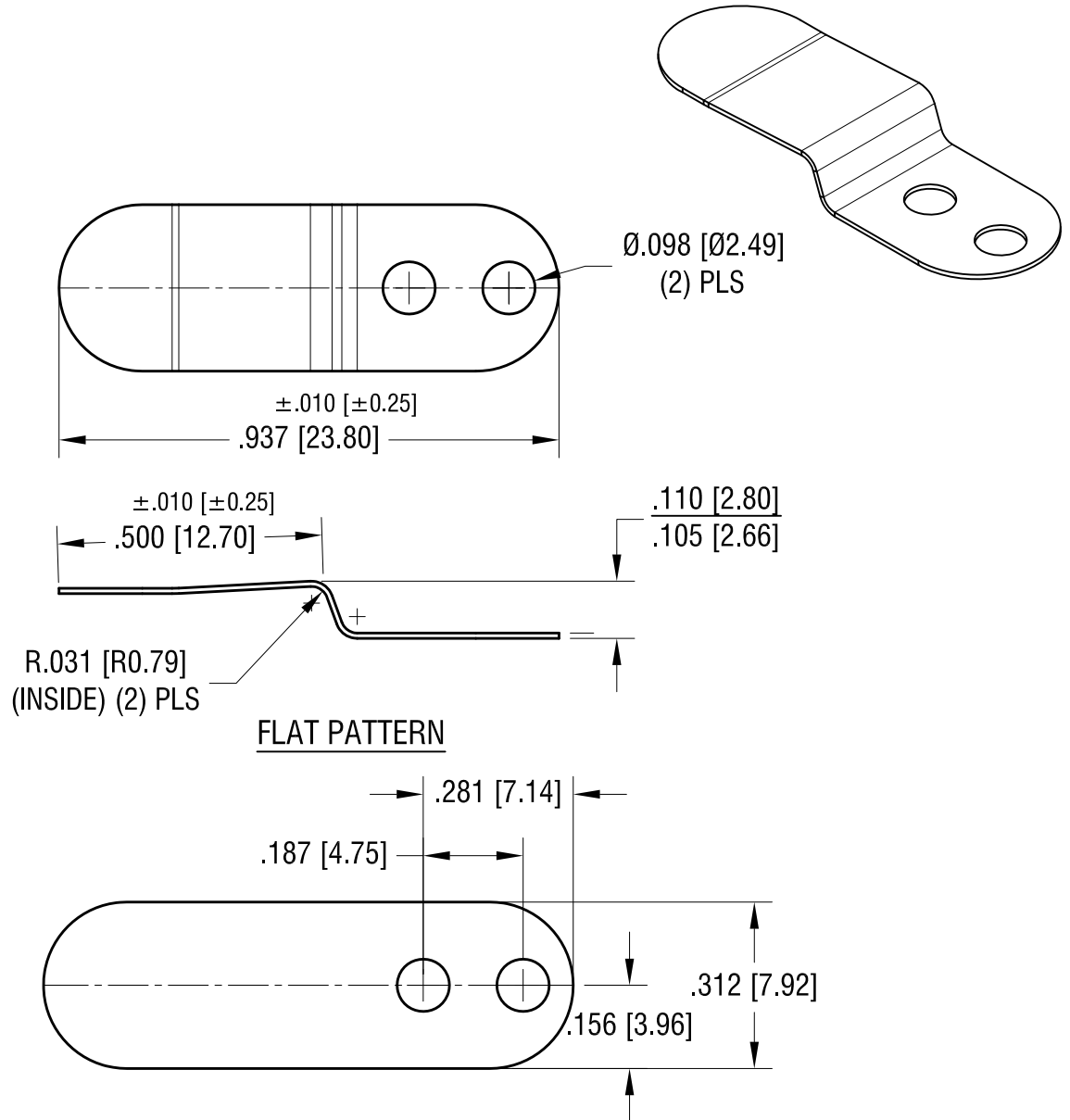

<b>KEYSTONE ELECTRONICS CORP.</b>			
www.keyelco.com • ASTORIA, N.Y. 11105-2017 • Tel (718) 956-8900			
PART NAME		SPRING CONTACT	
MATERIAL		.010 [0.25] TH'K PHOSPHOR BRONZE	
FINISH		DRN BY LN	DATE 11.25.81
NICKEL PLATE		APP'D	SCALE 3X
TOLERANCES	INCH [MM]	CODE	DWG NO.
DECIMAL	$\pm .005 [\pm 0.13]$	C/M	115
ANGULAR	$\pm 1^\circ$		
UNLESS OTHERWISE SPECIFIED			

2.23.11	REDRAWN IN CAD FORMAT	—
DATE	DESCRIPTION	REV.