

DATE	DESCRIPTION	REV.
------	-------------	------

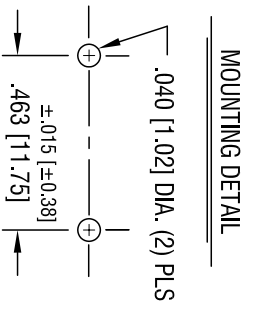
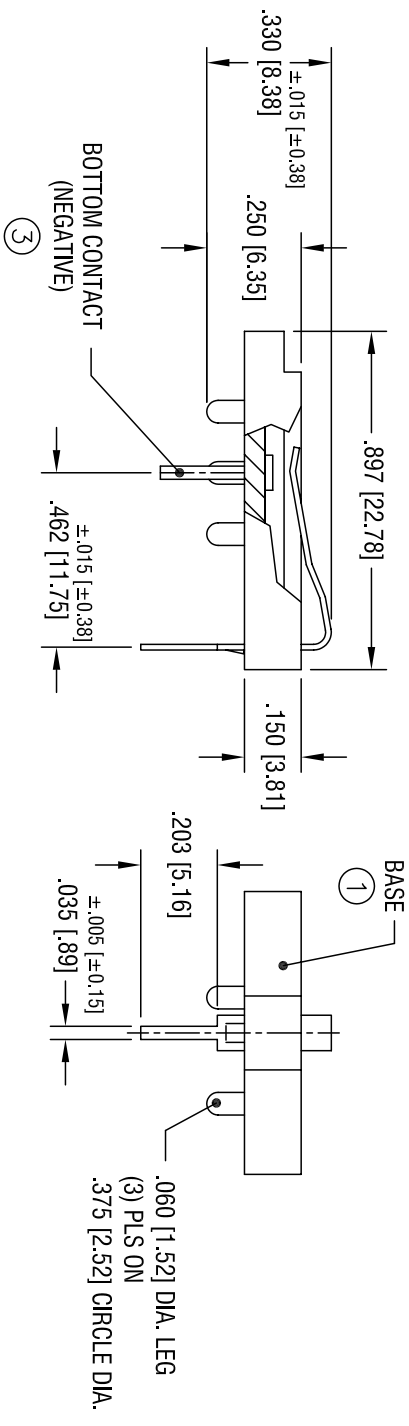
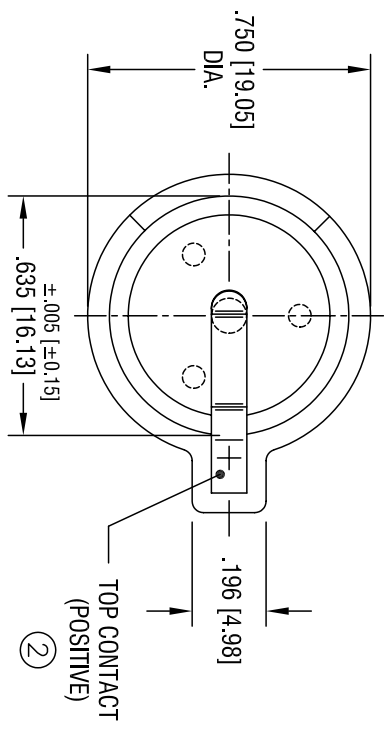

ITEM	DESCRIPTION/MATERIAL	FINISH
①	BASE, BLACK PBT (UL 94V-0)	TIN NICKEL PLATE
②	TOP CONTACT .015 [0.38] THK SPRING STEEL	
③	BOTTOM CONTACT .035 [0.89] DIA. STEEL	

KEYSTONE ELECTRONICS CORP.		ASTORIA, N.Y. 11105-2017	
PART NAME		1632 COIN CELL BATTERY HOLDER	
MATERIAL		AS NOTED	
FINISH	AS NOTED	DRN BY	BOONE
DATE	10.10.06	APPD	SCALE
2.5X		DWG NO.	502-3

THIS DOCUMENT IS THE PROPERTY OF KEYSTONE ELECTRONICS CORP. AND IS NOT TO BE REPRODUCED OR USED AS A BASIS FOR MANUFACTURE WITHOUT PRIOR WRITTEN PERMISSION FROM KEYSTONE ELECTRONICS CORP.