

THIS DOCUMENT IS THE PROPERTY OF
KEYSTONE ELECTRONICS CORP. AND
SHALL NOT BE REPRODUCED, DISTRIBUTED
OR USED AS A BASIS FOR MANUFACTURE
WITHOUT PRIOR WRITTEN PERMISSION
FROM KEYSTONE ELECTRONICS CORP.

RECOMMENDED SPACING FOR PC LUGS

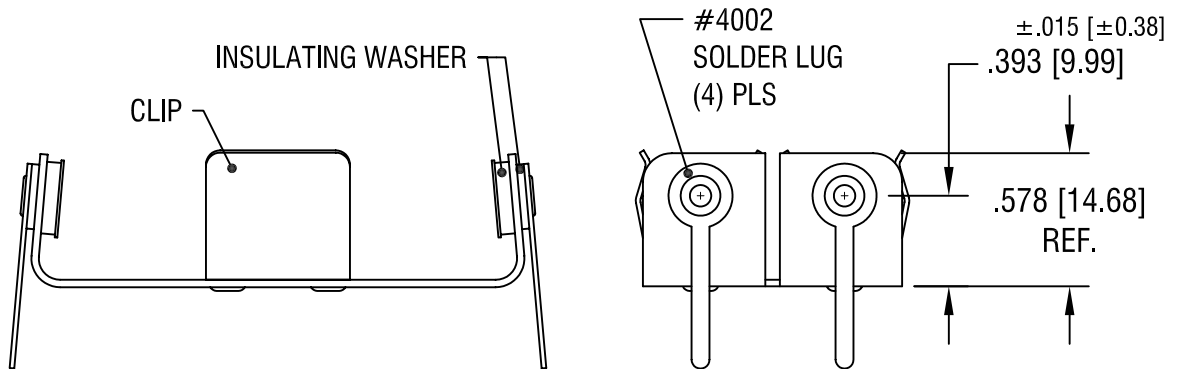
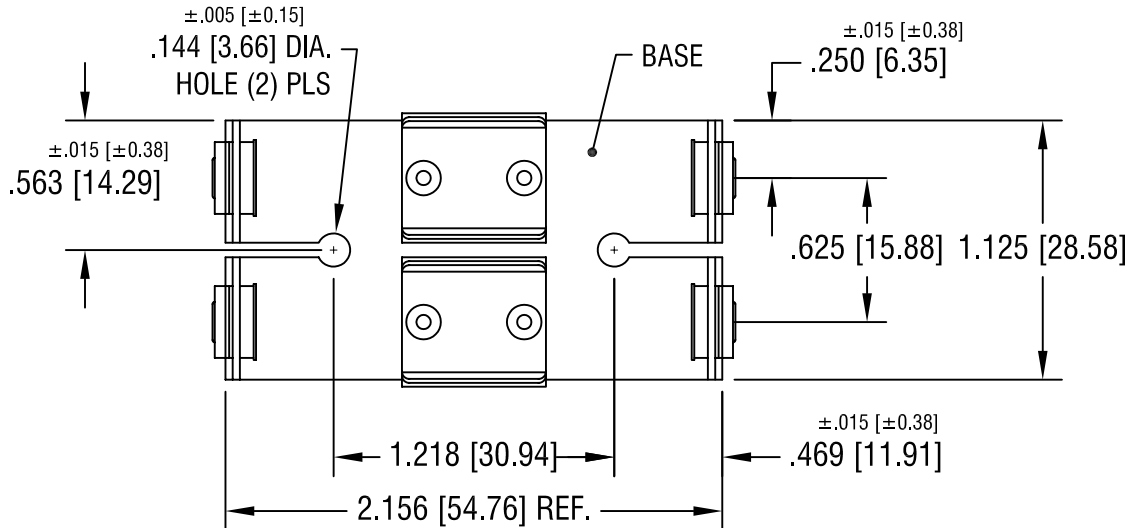
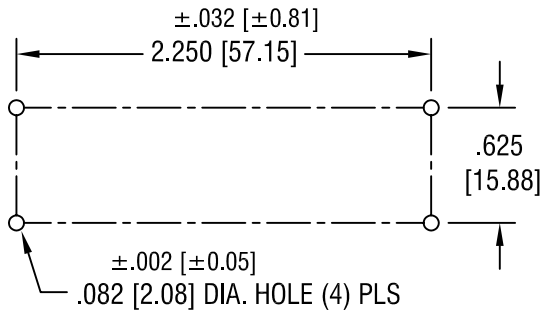

NOTES:

- 1. BASE: MAT'L - .032 [.81] TH'K ALUMINUM
- CLIP: MAT'L - .020 [.50] TH'K ALUMINUM
- SOLDER LUG: MAT'L - BRASS
- FINISH - TIN PLATE

KEYSTONE ELECTRONICS CORP.

ASTORIA, N.Y. 11105-2017

PART NAME				BATTERY HOLDER (2) 'AA'	
MATERIAL				AS NOTED	
FINISH		DRN BY	BOONE	DATE	6.28.07
AS NOTED		APP'D		SCALE	1.2X
TOLERANCES	INCH	[MM]	CODE	DWG NO.	
DECIMAL	± .010	[± 0.25]	C	2223	
ANGULAR ± 1°			UNLESS OTHERWISE SPECIFIED		

DATE	DESCRIPTION	REV.