

REV	DATE	DESCRIPTION	BY	CHK	APP
00		SEE SHEET 1			

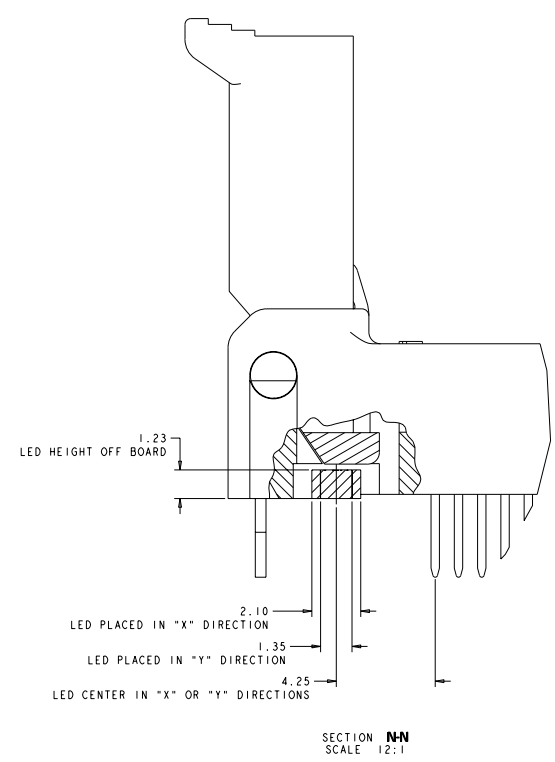

THIS DRAWING IS A CONTROLLED DOCUMENT.		REV. NUMBER: 00	REV. DATE: 09SEP2004	 TE Connectivity
DRAWING NO: 000000000000 PART NO: 000000000000 QTY: 000000000000 UNIT: 000000000000 DATE: 000000000000	DRAWING TITLE: 000000000000 PART NAME: 000000000000 PROJECT NO: 000000000000 REV: 000000000000 DATE: 000000000000	DRAWING NO: 000000000000 PART NO: 000000000000 QTY: 000000000000 UNIT: 000000000000 DATE: 000000000000	DRAWING TITLE: 000000000000 PART NAME: 000000000000 PROJECT NO: 000000000000 REV: 000000000000 DATE: 000000000000	
CUSTOMER DRAWING		STATE: CA COUNTY: 000000000000 CITY: 000000000000 ZIP: 000000000000	STATE: CA COUNTY: 000000000000 CITY: 000000000000 ZIP: 000000000000	DRAWING NO: 000000000000 PART NO: 000000000000 QTY: 000000000000 UNIT: 000000000000 DATE: 000000000000

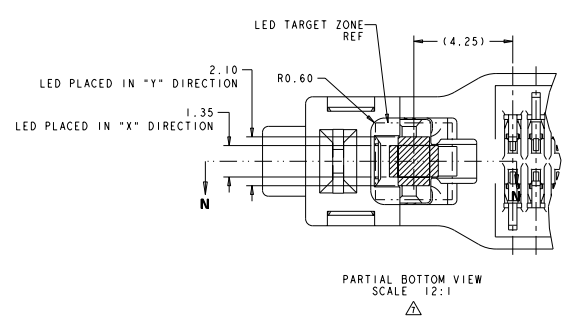