

THIS DOCUMENT CONTAINS DATA PROPRIETARY TO PROJECTS UNLIMITED, INC. ANY USE OR REPRODUCTION, IN ANY FORM, WITHOUT PRIOR WRITTEN PERMISSION OF PROJECTS UNLIMITED, INC. IS PROHIBITED.
© 2003, Projects Unlimited Inc.

SPECIFICATIONS

PARAMETERS	VALUES	UNITS
RATED VOLTAGE (SQUARE WAVE)	1.5	Vp-p
OPERATING VOLTAGE RANGE	1 ~ 3	Vp-p
RATED CURRENT (MAX)	30	mA
COIL RESISTANCE	15±4	OHM
MINIMUM SPL @ 10 CM	80	dBA
RESONANT FREQUENCY	2,400	Hz
OPERATING TEMPERATURE	-20 ~ +70	°C
STORAGE TEMPERATURE	-30 ~ +80	°C
HOUSING MATERIAL	PA46	-
TERMINAL MATERIAL	PbSn-PLATED BRASS	-
WEIGHT	5	grams

REVISIONS			
LTR	DESCRIPTION	DATE	APPROVED
-	RELEASED FROM ENGINEERING	6/23/99	
A	ADDED ELECTRICAL SPECIFICATION	5/22/02	S.J.
B	REVISED TO NEW TEMPLATE	4/26/04	R.W.

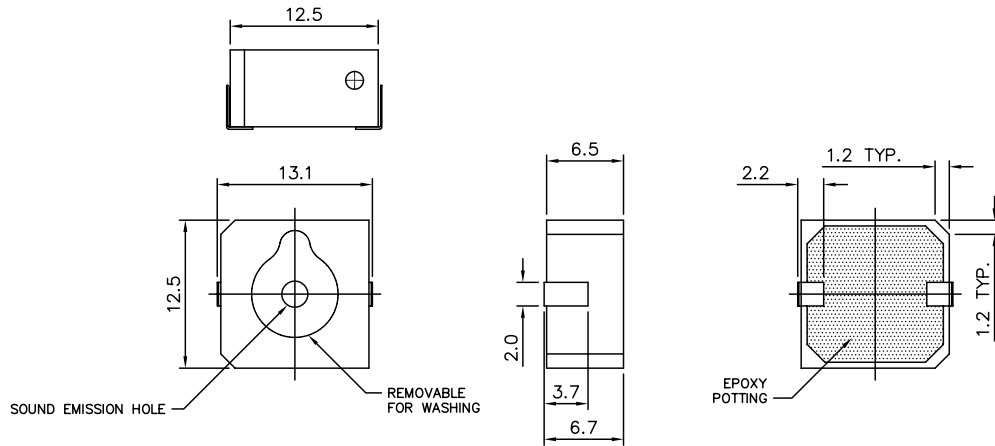

NOTES:

1. ALL DIMENSIONS ARE IN MILLIMETERS.
2. SPECIFICATION SUBJECT TO CHANGE OR WITHDRAWAL WITHOUT NOTICE.

FILE NAME
SMT-11.DWG

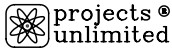
UNLESS OTHERWISE SPECIFIED: DIMENSIONS ARE IN MILLIMETERS; TOLERANCES ARE ±0.5 AND ANGLES ARE ±3°.		 Dayton, Ohio							
<table border="1"> <thead> <tr> <th>APPROVALS</th> <th>DATE</th> </tr> </thead> <tbody> <tr> <td>DRAWN TMM</td> <td>6/99</td> </tr> <tr> <td>APPROVED S.J.</td> <td>6/99</td> </tr> </tbody> </table>		APPROVALS	DATE	DRAWN TMM	6/99	APPROVED S.J.	6/99	SURFACE MOUNT TRANSDUCER SMT-11	
APPROVALS	DATE								
DRAWN TMM	6/99								
APPROVED S.J.	6/99								
DO NOT SCALE DRAWING		SIZE A	DRAWING NO. SMT-11						
		SCALE: N.T.S.	SHEET 1 OF 1						