

PLM2S-C



- For indoor use
- Used to fasten and identify bundles at the same time
- One-piece construction for consistent performance and reliability
- Can be marked with *PANDUIT* marker pens or custom imprinted with text, symbols, or trademarks available using *PANDUIT* Custom Hot Stamping Service
- Curved tip is easy to pick up from flat surfaces and allows faster initial threading to speed installation

▪ Part Number	PLM2S-C
▪ RoHS Compliancy Status	Compliant
▪ Part Description	Marker Tie, Wrap, 7.4", Standard cross section
▪ Product Type	Cable Ties
▪ Material	Nylon 6.6
▪ Color	Natural
▪ CSA Certified	Yes
▪ Mil. Std. Part Number	MS3368-1-9A
▪ UL Listed (File #E56854)	No
▪ UL Recognized (File #E56854)	Yes
▪ Length (In.)	7.4
▪ Length (mm)	188
▪ Width (In.)	.185
▪ Width (mm)	4.7
▪ CE Compliant	Yes
▪ Cross Section	Standard
▪ Head Height (In.)	.220
▪ Head Height (mm)	5.6
▪ Head Width (In.)	.320
▪ Head Width (mm)	8.1
▪ Locking Style	Locking
▪ Marker Type	Wrap
▪ Marker Write-On Area (In.)	.44 x .87
▪ Marker Write-On Area (mm)	11.1 x 22.1
▪ Material Flammability Rating	UL 94V-2
▪ Max. Bundle Diameter (In.)	1.75

▪ Max. Bundle Diameter (mm)	45
▪ Max. Continuous Use Temperature	185°F (85°C)
▪ Min. Loop Tensile Strength (Lbs.)	50
▪ Min. Loop Tensile Strength (N)	222
▪ Pricing Description	Marker Tie, Wrap, 7.4"L (188mm), Standard, Nylon, Natural
▪ Thickness (In.)	.052
▪ Thickness (mm)	1.3
▪ Tool	GTS, GTSL, GS2B, GTH, GS4H, PTS, PTH, PPTS, STS2, STH2
▪ Min. Order UOM	PC
▪ Min. Order Qty.	100
▪ BOM Qty. (# of Pkgs.)	

THIS COPY IS PROVIDED ON A RESTRICTED BASIS AND IS NOT TO BE USED IN ANY WAY DETRIMENTAL TO THE INTERESTS OF PANDUIT CORP.

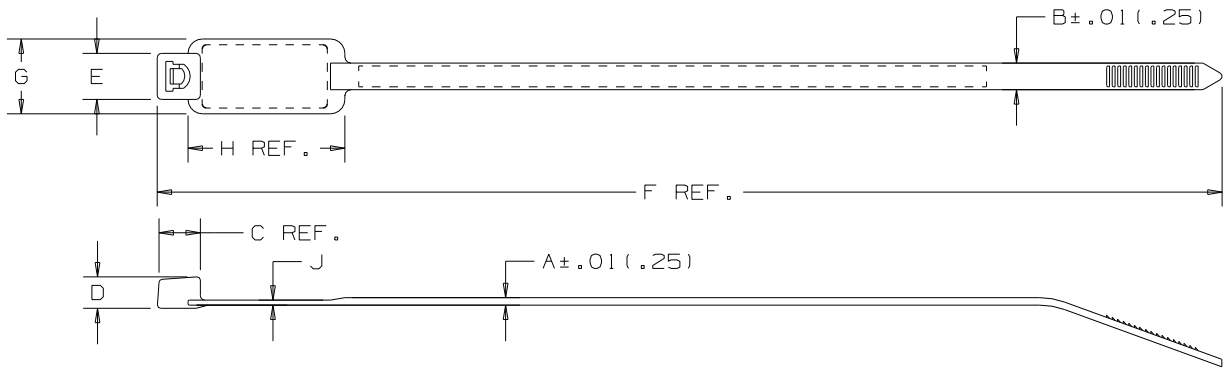

PANDUIT PART NO.*	BUNDLE DIA.		A in (mm)	B in (mm)	C in (mm)	D in (mm)	E in (mm)	F in (mm)	G in (mm)	H in (mm)	J in (mm)	WRITE-ON AREA in (mm)	MIN. LOOP TENSILE lbs. (N)	CROSS-SECTION	WEIGHT lbs/100pcs. (g)
	MIN. in (mm)	MAX. in (mm)													
PLM2S	.37 (9.5)	1.75 (45.1)	.052 (1.3)	.185 (4.7)	.258 (6.6)	.220 (5.6)	.320 (8.1)	7.4 (188)	.520 (13.2)	1.09 (27.7)	.035 (.9)	.44 × .87 (11.1 × 22.1)	50 (222)	STANDARD	.3 (147)
PLM4S	.75 (19)	4.00 (102)	.052 (1.3)	.185 (4.7)	.258 (6.6)	.220 (5.6)	.320 (8.1)	14.6 (371)	.520 (13.2)	2.10 (53.3)	.040 (1.0)	.44 × 2.00 (11.1 × 50.8)	50 (222)	STANDARD	.6 (272)

NOTES:

- *1) SEE CURRENT PRICE SHEET FOR PART NUMBER SUFFIX DESIGNATION FOR PACKAGE SIZE AND PART COLOR.
- 2) RECOGNIZED UNDER THE COMPONENT PROGRAM OF UNDERWRITERS LABORATORIES INC.

DIMENSIONS IN PARENTHESES ARE IN METRIC UNITS.

PANDUIT CORP. TINLEY PARK, ILLINOIS

PAN-TY® MARKER TIE
PLM SERIES

UNLESS OTHERWISE SPECIFIED,
DIMENSIONAL TOLERANCES ARE:
(.X) ± .005 (.XXX) ± .020 (.51)
(.XX) ± .02 (.5) ANGLES ± .005

UNLESS OTHERWISE SPECIFIED,
ALL DIMENSIONS ARE GIVEN
IN INCHES, THIRD ANGLE PROJECTION.

DRAWN BY
L.V/AJC

DATE
3-29-71

CHK'D
HVP

MAT'L:

NYLON 6.6

SCALE
NONE

DRAWING NO.
SS-2880

DWG
SIZE
A

REV	DATE	BY	CHK	DESCRIPTION	ECN	R	CUST	SUP
6	6/27/06	ERW		CORRECTED REFERENCE DIMENSIONS.	2880	6		