

THIS DOCUMENT IS THE PROPERTY OF  
KEYSTONE ELECTRONICS CORP. AND  
SHALL NOT BE REPRODUCED, DISTRIBUTED  
OR USED AS A BASIS FOR MANUFACTURE  
WITHOUT PRIOR WRITTEN PERMISSION  
FROM KEYSTONE ELECTRONICS CORP.

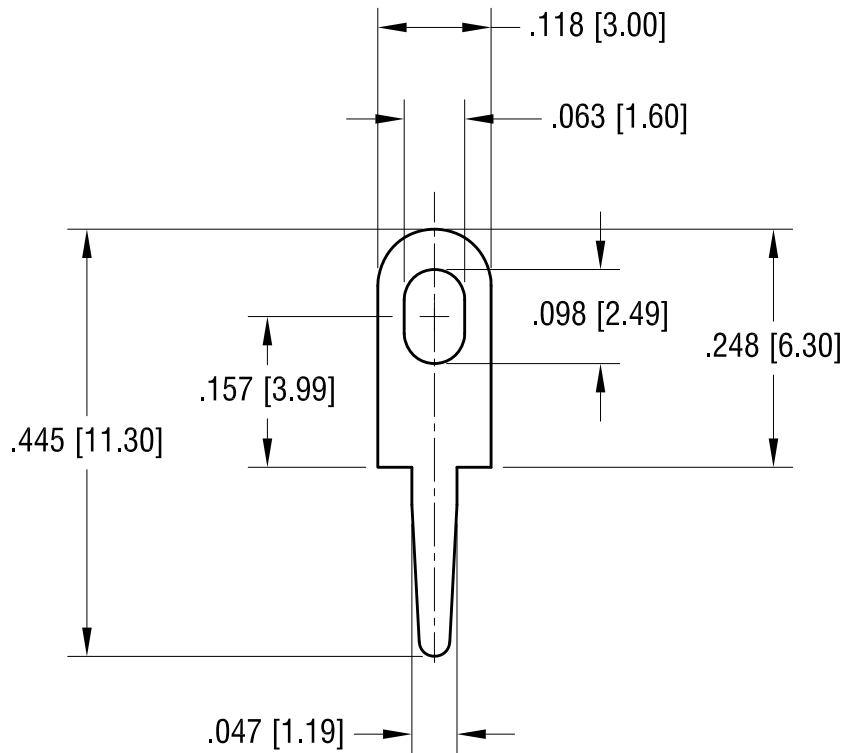
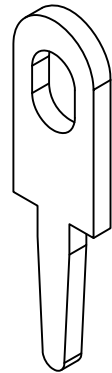

**KEYSTONE ELECTRONICS CORP.**

www.keyelco.com • ASTORIA, N.Y. 11105-2017 • Tel (718) 956-8900

PART NAME		PC TEST POINT TERMINAL	
MATERIAL		.025 [0.63] TH'K BRASS	
FINISH	DRN BY	DATE	
MATTE TIN PLATE	BOONE	7.31.95	
	APP'D	SCALE	
		5X	
TOLERANCES	INCH	[MM]	CODE
DECIMAL	± .005	[± 0.15 ]	
ANGULAR	± 1°		C/M
UNLESS OTHERWISE SPECIFIED			DWG NO.
			4952

7.01.09	CHANGE AS PER ECN 09-093	A
DATE	DESCRIPTION	REV.