

THIS DOCUMENT IS THE PROPERTY OF KEYSTONE ELECTRONICS CORP. AND SHALL NOT BE REPRODUCED, DISTRIBUTED OR USED AS A BASIS FOR MANUFACTURE WITHOUT PRIOR WRITTEN PERMISSION FROM KEYSTONE ELECTRONICS CORP.

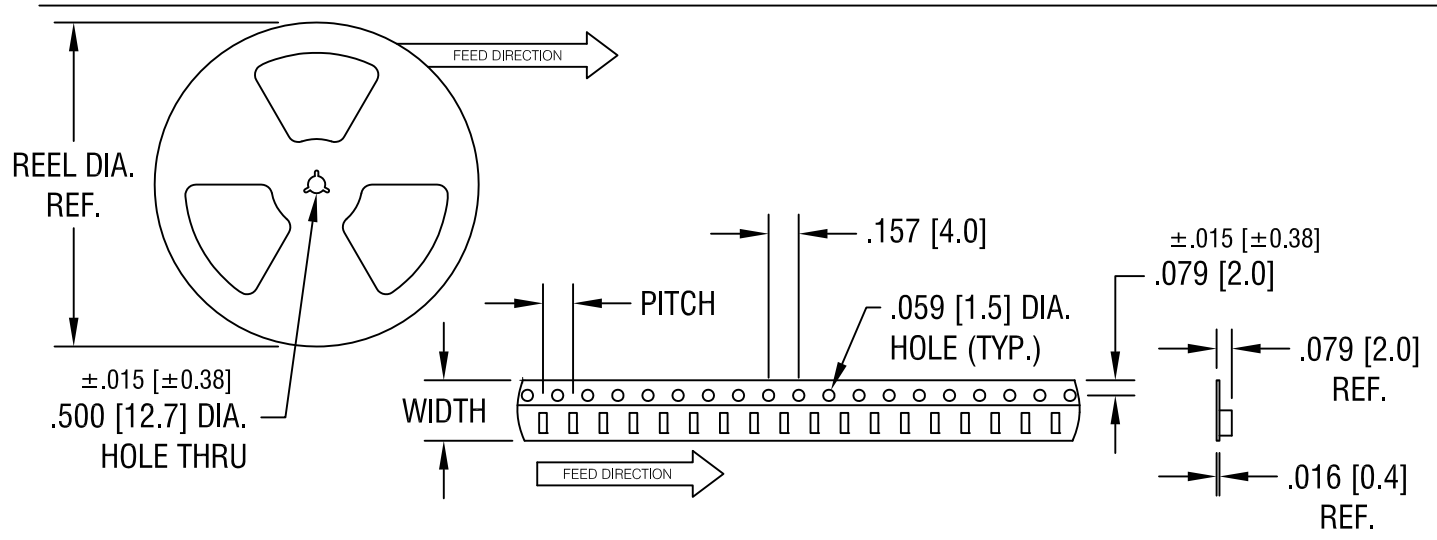
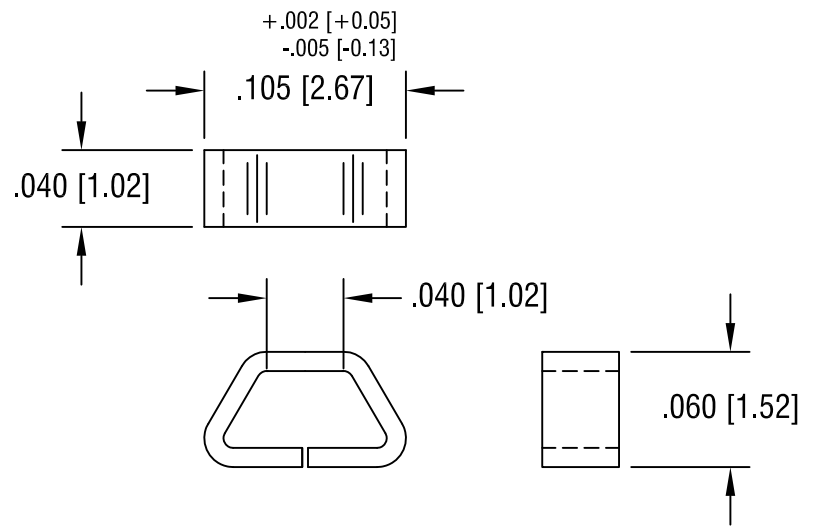
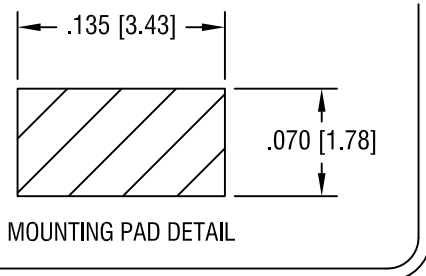

NOTES:

1. SUPPLIED ON TAPE AND REEL ONLY.
TAPES AND REEL SPECIFICATIONS:
2. TAPE:
MAT'L - ALL CONDUCTIVE POLYSTYRENE CARRIER
ANSI/EIA-481 STANDARD
.315 [8.0] WIDE; .157 [4.0] PITCH
3. REEL:
13.0 [330.2] DIA. 5000 PIECES OF
PART NO. 5017 PER REEL.

KEYSTONE ELECTRONICS CORP.			
www.keyelco.com • ASTORIA, N.Y. 11105-2017 • Tel (718) 956-8900			
PART NAME			
TEST POINT, MINIATURE, SURFACE MOUNT			
MATERIAL			
.010 [0.25] TH'K PHOSPHOR BRONZE			
FINISH		DRN BY	DATE
SILVER PLATE		BOONE	5.1.01
		APP'D	SCALE
			10X, 1X
TOLERANCES	INCH [MM]	CODE	DWG NO.
DECIMAL	± .005 [± 0.15]	C/M	5017
ANGULAR	± 1°		
UNLESS OTHERWISE SPECIFIED			

3.11.10	CHANGE AS PER ECN 10-022	C
6.20.07	CHANGE AS PER ECN 07-039	B
DATE	DESCRIPTION	REV.