

THIS DOCUMENT IS THE PROPERTY OF  
KEYSTONE ELECTRONICS CORP. AND  
SHALL NOT BE REPRODUCED, DISTRIBUTED  
OR USED AS A BASIS FOR MANUFACTURE  
WITHOUT PRIOR WRITTEN PERMISSION  
FROM KEYSTONE ELECTRONICS CORP.

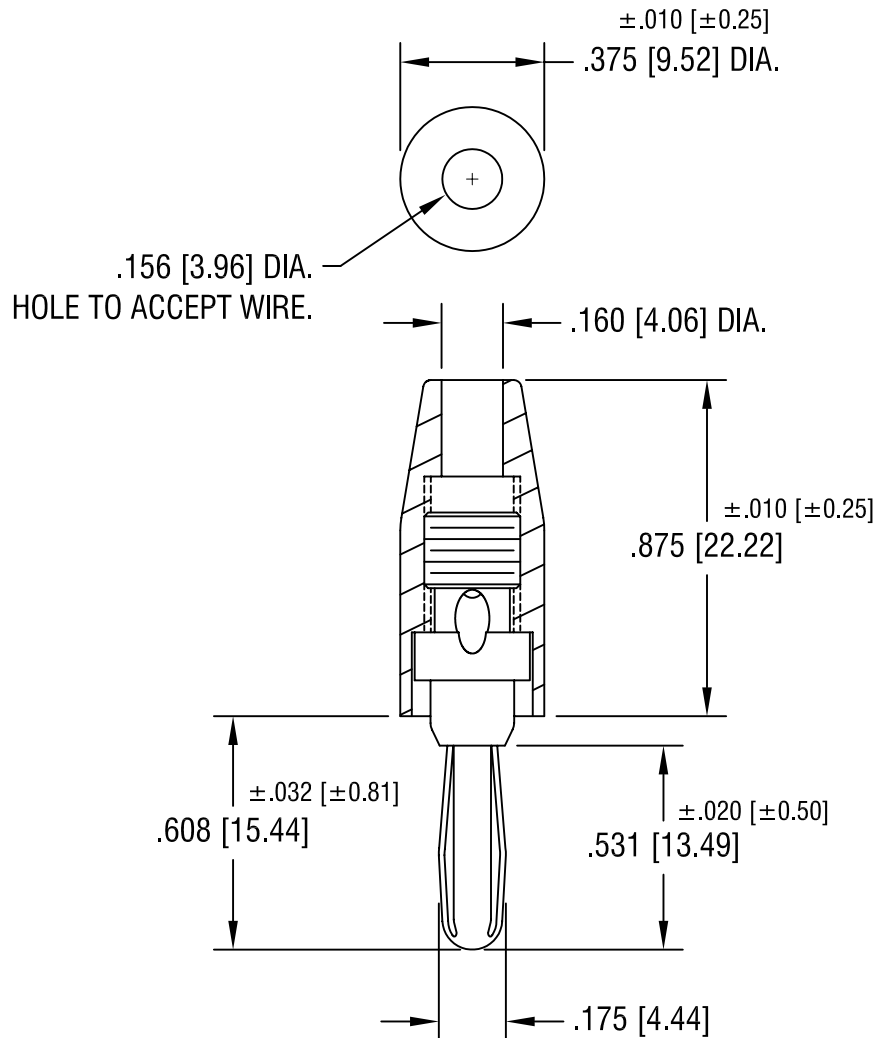

NOTES:

- 1. SPRING: MAT'L - NICKEL SILVER
- BODY: MAT'L - BRASS
- FINISH - NICKEL PLATE
- HANDLE: MAT'L - NYLON

PART NO.	COLOR
6078	RED
6079	BLACK

KEYSTONE ELECTRONICS CORP.			
ASTORIA, N.Y. 11105-2017			
PART NAME BANANA PLUG, SOLDERLESS CONNECTION			
MATERIAL AS NOTED			
FINISH AS NOTED		DRN BY BOONE	DATE 1.16.06
		APP'D	SCALE 2X
TOLERANCES	INCH [MM]	CODE	DWG NO.
DECIMAL	$\pm .005$ [ $\pm 0.15$ ]	C/M	6078-6079
ANGULAR	$\pm 1^\circ$		
UNLESS OTHERWISE SPECIFIED			

DATE	DESCRIPTION	REV.