

Current refinements (click to remove)

[Search Tips](#) 
 [Region](#) [USA](#) [Product Family](#) [Ring Terminal, Non-Insulated – High Temperature](#) [Text Search: 'P10-10RHT6-L'](#)
Your search criteria matched only one product, shown below.

- Nickel plated copper for temperatures up to 650°F (343°C)
- Internal barrel serrations assure good wire contact and maximum tensile strength
- Brazed seam protects terminal barrel from splitting during the crimp process
- Barrel of terminal internally beveled to provide quick and easy wire insertion

‡UL and CSA approved tooling/product combinations.



Part Number:	P10-10RHT6-L
RoHS Compliance Status:	Compliant
Part Description:	High Temperature Ring Terminal, 12 – 10 AWG, #10 stud size, non-insulated.
Product Type:	Terminals
Length (In.):	.81
Width (In.):	.38
Angle:	straight
Clearance:	.33
Stock:	.04
Stud Size:	#10
Tool:	CT-100A, CT-200, CT-600-A, CT-1570, CT-1701, CT-2500
Wire Range:	12 – 10 AWG
Wire Range (mm ²):	4.0 - 6.0
Min. Order UOM:	PC
Min. Order Qty.:	50
BOM Qty. (# of Pkgs.)	
Add to My Catalog	

 Please [register](#) to utilize the 'Bill of Materials', 'Submit Quotes' and 'My Catalog' features.

THIS COPY IS PROVIDED ON A RESTRICTED BASIS AND IS NOT TO BE USED IN ANY WAY DETRIMENTAL TO THE INTERESTS OF PANDUIT CORP.

PANDUIT PART NUMBER	STUD SIZE	DIMENSIONS in.				
		A $\pm .02$	W $\pm .01$	C $\pm .02$	M $\pm .02$	H $\pm .01$
P10-6RHT6	#6	.78 (19.81)	.31 (7.87)	.35 (8.89)	.62 (15.75)	.15 (3.81)
P10-8RHT6	#8	.78 (19.81)	.31 (7.87)	.35 (8.89)	.62 (15.75)	.17 (4.32)
P10-10RHT6	#10	.81 (20.57)	.38 (9.65)	.33 (8.38)	.62 (15.75)	.20 (5.08)
P10-14RHT6	1/4"	.96 (24.38)	.53 (13.46)	.42 (10.67)	.70 (17.78)	.27 (6.86)

NOTES:

- RECOMMENDED FOR:
 - #12-10 AWG SOLID OR STRANDED COPPER WIRE *
 - 650° F (343° C) MAX. TEMP. RATING
- MATERIAL:
 - STAMPING- .04" (1.02) THK COPPER, NICKEL PLATED
- PACKAGE QTY:

STD. PKG. - L	= 50
BULK PKG. - D	= 500
- DIMENSIONS IN BRACKETS ARE IN MILLIMETERS
- INSTALLATION TOOLS:
 - PANDUIT APPROVED: CT-100, CT-200, CT-160, CT-260, CT-570, CT-1570

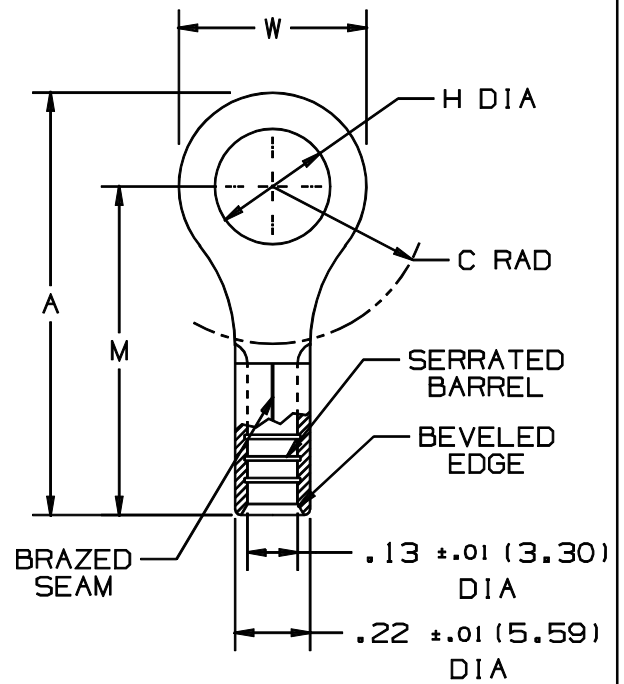

* APPROVED FOR USE WITH # 14 - 10 AWG SOLID OR STRANDED COPPER WIRE WHEN INSTALLED WITH THE CT-570 OR CT-1570 TOOLS

A41267_01

										PANDUIT CORP.		TINLEY PARK, ILLINOIS			
01	1/01	RM	FILESPEC WAS N41267AA_PCD_00								#12-10 BARREL NON-INSULATED RING TONGUE, HIGH TEMPERATURE, 650° F				
00	1/96	ED	REV.S TON NOTES & DIM.S/ FILESPEC WAS: A41267A				03883								
REV	DATE	BY	CHK	DESCRIPTION				ECN#	CUST	PM	APP	DRAWN BY	CHK'D	SCALE	DRAWING NO.
												EJD		NONE	A41267