

Current refinements (click to remove)

[Search Tips](#) 
 [Region](#) **USA** [Product Family](#) **Ring Terminal, Nylon Insulated** [Text Search](#): 'PN10-8R-D'

Your search criteria matched only one product, shown below.

- Ring tongue design assures a secure connection in high vibration applications
- Metal insulation grip sleeve crimps to wire insulation, providing protection to the crimp joint during high vibration applications
- Internal barrel serrations assure good wire contact and maximum tensile strength
- UL Flammability UL 94V-2/HB, maximum insulation temperature 221°F (105°C)
- UL and CSA rated up to 600 V per UL 486

‡UL and CSA approved tooling/product combinations.

Note: Wire sizes #26 – #22 AWG, are not UL Listed or CSA Certified.

Related Products
[Hand Operated Plier Type Tools](#)
[Contour Crimp™ Control...](#)
[Pneumatic Crimping Tool](#)

Part Number:	PN10-8R-D
RoHS Compliancy Status:	Compliant
Part Description:	Ring Terminal, 12 – 10 AWG, #8 stud size, nylon insulated.
Product Type:	Terminals
CSA Certified:	Yes
Mil. Std. Part Number:	MS25036-156 (Class 1 & 2)
UL Listed:	Yes
Length (In.):	1.06
Length (mm):	27.4
Width (In.):	.37
Width (mm):	9.40
Angle:	straight
Clearance:	.31
Max. Ins.:	.225
Panduit Color Code:	Yellow
Stock:	.04
Stud Size:	#8
Tool:	CT-100A‡, CT-600-A‡, CT-1550‡, CT-1551‡, CT-2500‡
Wire Range:	12 – 10 AWG
Wire Range (mm²):	4.0 - 6.0
Min. Order UOM:	PC
Min. Order Qty.:	500
BOM Qty. (# of Pkgs.)	

[Add to My Catalog](#)

 Please [register](#) to utilize the 'Bill of Materials', 'Submit Quotes' and 'My Catalog' features.

THIS COPY IS PROVIDED ON A RESTRICTED BASIS AND IS NOT TO BE USED IN ANY WAY DETRIMENTAL TO THE INTERESTS OF PANDUIT CORP.

PANDUIT PART NUMBER	MILITARY PART NO. AND CLASS	STUD SIZE	DIMENSIONS in.				
			A $\pm .04$	W $\pm .01$	C $\pm .02$	G $\pm .04$	H $\pm .01$
PN10-6R	MS25036-111 CLASS 1 & 2	#6	1.06 (26.9)	.37 (9.4)	.31 (7.9)	.88 (22.3)	.15 (3.8)
PN10-8R	MS25036-156 CLASS 1 & 2	#8	1.06 (26.9)	.37 (9.4)	.31 (7.9)	.88 (22.3)	.17 (4.3)
PN10-10R	MS25036-112 CLASS 1 & 2	#10	1.06 (26.9)	.38 (9.7)	.31 (7.9)	.88 (22.3)	.20 (5.1)
PN10-14R	MS25036-157 CLASS 1 & 2	1/4"	1.21 (30.7)	.52 (13.2)	.38 (9.7)	.95 (24.1)	.27 (6.9)
PN10-56R	MS25036-113 CLASS 1 & 2	5/16"	1.21 (30.7)	.52 (13.2)	.38 (9.7)	.95 (24.1)	.33 (8.4)
PN10-38R	MS25036-114 CLASS 1 & 2	3/8"	1.29 (32.8)	.58 (14.7)	.43 (10.9)	1.00 (25.4)	.39 (9.9)
PN10-12R	-----	1/2"	1.47 (37.3)	.72 (18.3)	.53 (13.5)	1.11 (28.2)	.52 (13.2)

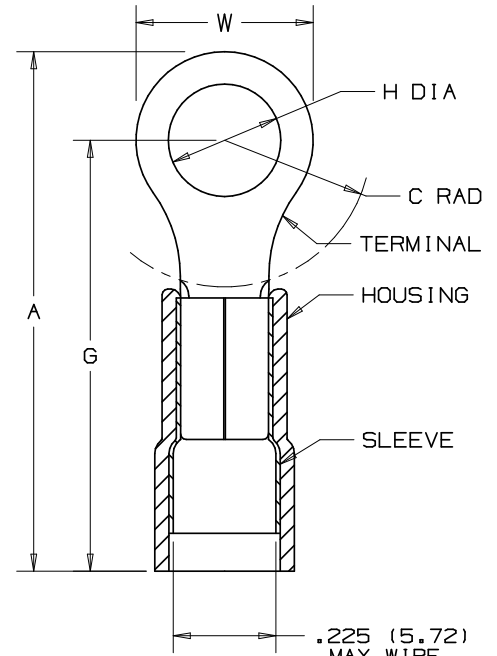

NOTES:

- UL LISTED AND CSA CERTIFIED FOR:
 - 600V. MAX. BLDG. WIRE (1000V. MAX. IN SIGNS, FIXTURES & LUMINARIES)
 - 221°F. (105°C) MAX. TEMP. RATING
 - #12-10 AWG STRANDED AND #12 AWG SOLID COPPER WIRE WITH THE CT-1550 AND CT-1551 INST. TOOLS
 - #12-10 AWG SOLID OR STRANDED COPPER WIRE WITH THE CT-100 INSTALLATION TOOL.
 - MIL CLASS 2 WITH THE CT-460 INSTALLATION TOOL
- MATERIAL:
 - STAMPING- .04" (1.02) THK. COPPER, TIN PLATED
 - HOUSING- NYLON, YELLOW
 - SLEEVE- BRASS, TIN PLATED
- WIRE STRIP LENGTH- 9/32" +1/32, -0 (7.1, +.8, -0)
- PACKAGE QUANTITY: -L = 50, -D = 500
- DIMENSIONS IN PARENTHESIS ARE IN MILLIMETERS



Panduit part numbers shown on this drawing meet the material requirements of RoHS (EUROPEAN DIRECTIVES 2002/95/EC) as proposed by the Technical Adaptation Committee

A41186_09

REV	DATE	BY	CHK	DESCRIPTION	ECN #	CUST	PM	DRAWN BY	CHK'D	SCALE	DRAWING NO.
09	8/06	DAW	DAW	ADDED METRIC PART NO. & CLASS	TR00155	LCA	TRO	FES	LA	NONE	A41186
08	12/02	SAC	SKB	MADE ALL METRIC DIMS ONE PLACE	10504	LCA	TRO				
07	10/02	SAC	SKB	CHANGED DIM. M TO DIM. G. & DIM. C FOR PN10-12R WAS .56	10480	LA	TRO				
06	9/02	SAC	SKB	ADDED PN10-12R	10453	LA	TRO				



TINLEY PARK, ILLINOIS

3PC. NYLON INSULATED, 12-10 BARREL, RINGS