

Tous droits strictement réservés. Reproduction ou communication a des tiers interdite sous quelque forme que ce soit sans autorisation écrite du propriétaire. Propriété de c FCI. Droits de reproduction FCI.

All rights strictly reserved. Reproduction or issue to third parties in any form whatever is not permitted without written authority from the proprietor. Property of FCI. Copyright FCI.

PRODUCT NUMBER	NO OF POS	LOADED POSITION
94908-X88	8	ALL POS.
94908-X86		2,3,4,5,6,7
94908-X84		3,4,5,6
94908-X84A		1,2,3,6
94908-X88LF	8	ALL POS.
94908-X86LF		2,3,4,5,6,7
94908-X84LF		3,4,5,6
94908-X84ALF		1,2,3,6

NOTE: PLEASE CHECK FOR AVAILABILITY, NOT ALL OPTIONS AVAILABLE.

PLATING CODE	PLATING	HSG COLOR
0	30μ" G.X.T.	BLACK
1	15μ" AU	
2	20μ" GFDP	
3	30μ" AU	
4	15μ" G.X.T	
5	50μ" AU	

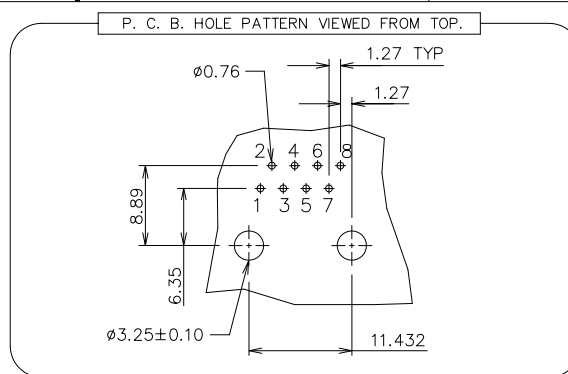

NOTES:

1. RECOMMENDED P.C.B THICKNESS 1.60 MM
2. HOUSING MAT'L: NYLON 66, 25% GLASS REINFORCED, UL94-V0, COLOR : SEE TABLE.
THE HOUSING WILL WITHSTAND EXPOSURE TO 260 DEGREES C PEAK TEMPERATURE FOR 10 SECONDS IN A WAVE SOLDER APPLICATION WITH A 1.60mm MIN THICK CIRCUIT BOARD.
3. CONTACTS: PHOS BRONZE ALLOY UNS-C51000, 0.460 DIA. ROUND WIRE. SEE TABLE FOR PLATING.
4. PROTRUDED SHELF ONLY APPEARS ON 8-POS JACK.
5. STANDARD PACKAGING METHOD (USE TUBE): SEE GES-14-361. PACKAGING OF LEAD FREE PRODUCTS MEETS LABELING AND PACKAGING SPECIFICATION GS-14-920.
6. COMPANY LOGO LOCATED IN THIS AREA ,AND WOULD APPEAR IN THE SAME SHIPMENT UNLESS LOGO SPEC HEREIN IS UPDATED.
7. LEAD FREE PRODUCTS MEET EUROPEAN UNION DIRECTIVES AND OTHER COUNTRY REGULATIONS AS DESCRIBED IN GS-22-008.

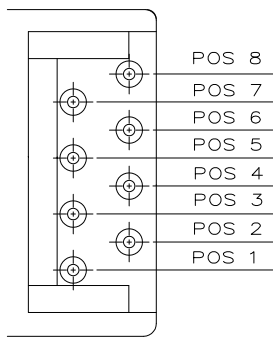

WIRE POSITION No

mat'l. code		tolerances unless otherwise specified		CUSTOMER COPY		 www.fciconnect.com	
ltr	ecn no	dr	date	linear	projection	title	
G				.X ±.3		MODIFIED LOW PROFILE PCB III	
				.XX ±.10		HORZ MOD JACK FOR 1.6MM P.C.B.	
				.XXX ±.050		product family MODJACK	
				angles 0° ±2°		size dwg no	
				dr DKLIN 7/6/94	MM	code 213	
				enrg TONY CHEN 7/6/94	scale 1:1	sheet 2 of 2	
				chr TONY CHEN 7/8/94		94908	
				appd TONY CHEN 7/8/94		cage code 22526	
sheet index	revision sheet						

ACAD