

PRODUCT NO.	CONDUCTOR TYP OF POS	CONDUCTOR ASS'Y POS. NO.
94104-x66(LF)	6/6	1,2,3,4,5,6
94104-x64(LF)	6/4	2,3,4,5
94104-x62(LF)	6/2	3,4
94104-x62i(LF)	6/2	1,6
94104-x44(LF)	4/4	1,2,3,4
94104-x42(LF)	4/2	2,3

- NOTE:
- FOR VISUAL MECHANICAL AND FUNCTIONAL REQUIREMENTS SEE PRODUCT SPEC.110-042.
 - HOUSING MAT'L:GLASS REINFORCED 66 NYLON ZYTEL-50. UL-94V-0
 - GOLD WIRE MAT'L:PHOS. BRONZE 0.44 DIA. PLATING:SEE TABLE.
 - A. STANDARD PACKAGING METHOD(USE TRAY)SEE GES-14-351.
B. NON-STANDARD PACKAGING METHOD (USE TUBE) SEE GES-14-358 THE PART NO. SHOULD BE SUFFIXED WITH 'T'.
 - IF LF P/N THE HOUSING WILL WITHSTAND EXPOSURE TO 260°C PEAK TEMPERATURE FOR 10 SECONDS IN A WAVE SOLDER APPLICATION WITH A 1.60mm MINIMUM THICK CIRCUIT BOARD

CODE*X*	PLATING	HOUSING COLOR
0	6u" Au 20u" Min NICKEL UNDERPLATED	GRAY
1	2u" Au 20u" Min NICKEL UNDERPLATED	
2	6u" Au 20u" Min NICKEL UNDERPLATED	BLACK
3	2u" Au 20u" Min NICKEL UNDERPLATED	

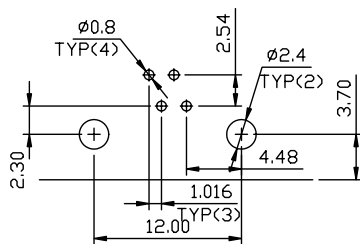
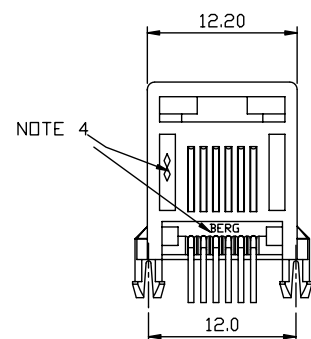
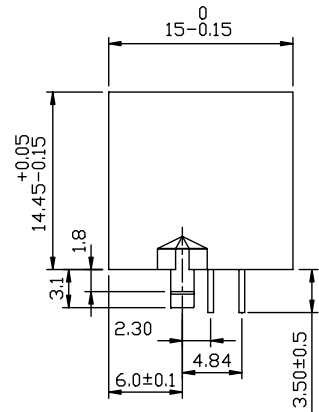
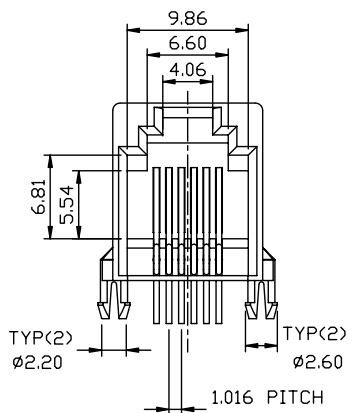
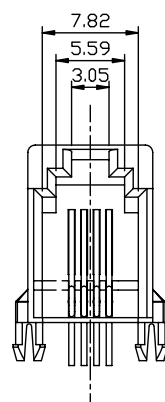

RECOMMENDED P.C.B.(.063 THK) PATTERN---4POS

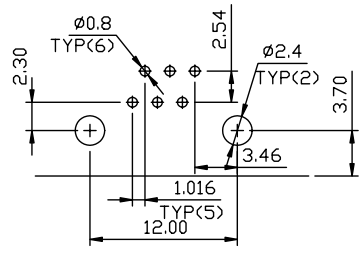

RECOMMENDED P.C.B.(.063 THK) PATTERN---6POS

mat'l. code		tolerances unless otherwise specified		CUSTOMER COPY	 www.fcjconnect.com
ltr	ecr no dr date	linear	.X ± 0.3	projection	
C	N05-0126 ZC 5/11/05		.XX ± 0.13	 MM/INCH	94104
D	N06-016d LONG 6/14/06		.XXX ± 0.05		
E	N06-0232 LONG 9/01/06	angles	±		
		dr	Zhengcai Tao 5/11/05		
		enr	Zhengcai Tao 5/11/05		
		chr	Zhengcai Tao 5/11/05		
		appd	Jason Zhou 5/11/05		
sheet index	revision sheet				

form no. 7530-001-104

Tous droits strictement reserves. Reproduction ou communication a des tiers interdite sous quelque forme que ce soit sans autorisation écrite au propriétaire de c FCI. Droits de reproduction FCI.



All rights strictly reserved. Reproduction or issue to third parties in any form whatever is not permitted without written authority from the proprietor. Property of FCI. Copyright FCI.