

NOTES:

- MATERIALS OF CONSTRUCTION:
 SHELL = ZINC DIE CAST, NICKEL PLATED (.000100 MIN THICK)
 BODY, FERRULE & RETAINER RING = BRASS (ASTM-B16 H02, C36000), NICKEL PLATED (.000100 MIN THICK)
 CONTACT PIN = BRASS (ASTM-B16 H02, C36000), GOLD PLATED (.000003 MIN THICK)
 WASHER = BRASS (00-B-613), NICKEL PLATED (.000100 MIN THICK)
 GASKET = SILICONE RUBBER, COLOR RED
 INSULATOR = DELRIN, COLOR NATURAL
 SPRING = COPPER, NICKEL PLATED (.000200 MIN THICK)
- CRIMPED FERRULE = HEX CRIMP SIZE .213
 CRIMPED CONTACT PIN = HEX CRIMP SIZE .068

31-326-RFX		REVISIONS			
DRAWING NO.	REV	DESCRIPTION	DATE	ECO	APPR
THIRD ANGLE PROJ.	A	RELEASE TO MFG.	3/6/02	43982	CPM

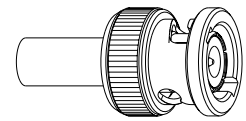

SCALE 2.000

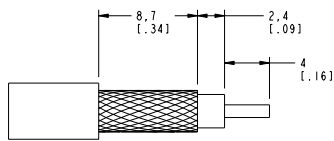
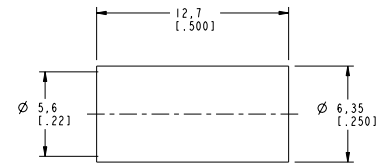
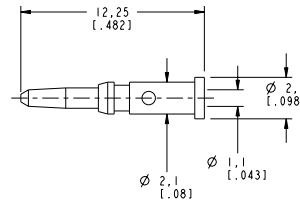
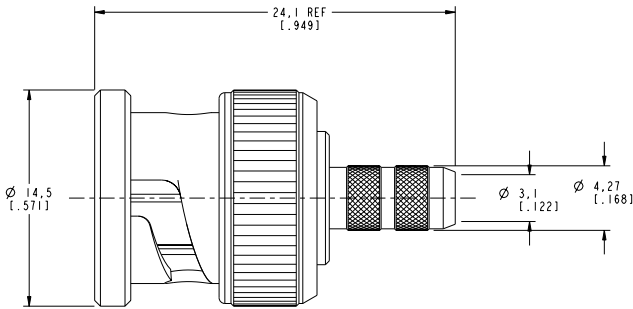

RECOMMENDED CABLE STRIPPING DIMENSIONS
SCALE 3.000

CUSTOMER OUTLINE DRAWING
ALL OTHER SHEETS ARE FOR INTERNAL USE ONLY

UNLESS OTHERWISE SPECIFIED, DIMENSIONS ARE IN INCHES AND TOLERANCES ARE: 0.5 - 6mm ±0.2mm 6 - 30mm ±0.4mm 30 - 120mm ±0.6mm	MATERIAL	DRAWN C. McGRATH	DATE 01-Mar-02	TITLE BNC CRIMP PLUG (FOR RG-55/U, 142A/U, 223/U, 400/U CABLES)	Amphenol Amphenol Corporation Communication and Network Products Division Danbury, CT U.S.A. 06810	
	REFERENCE EAR 507 GEN# ASSYM13.BNC	ENGINEER O. BARTHELME	DATE 01-Mar-02	APPROVED O. BARTHELME	DATE 3/6/02	SCALE: 4.0:1
NOTICE - These drawings, specifications, or other data (1) are, and remain the property of Amphenol Corp. (2) must be returned upon request; and (3) are confidential and not to be disclosed to any person other than those to whom they are given by Amphenol Corp. The furnishing of these drawings, specifications, or other data by Amphenol Corp., or to any other person for any purpose is not to be regarded by implication or otherwise in any manner licensing, granting rights or permitting such holder or any other person to manufacture, use or sell any product, process or design, patented or otherwise, that may in any way be related to or disclosed by said drawings, specifications, or other data.	CAD FILE 1:\BNC\31-326-RFX	CODE ID 74868	DWG SIZE B	DRAWING NO. 31-326-RFX	REV A	