

PRODUCT NUMBER
89947-YXXSLF

- LEAD FREE, RoHS COMPLIANT, NOTE 4
- STRAIN RELIEF OPTION, NOTE 5
- TOTAL NB OF POSITIONS, SHEET 2.
- FEATURES, SHEET 2.

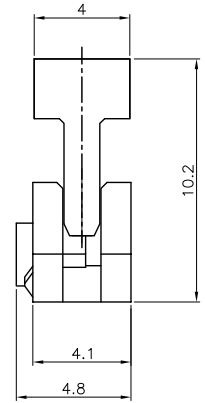
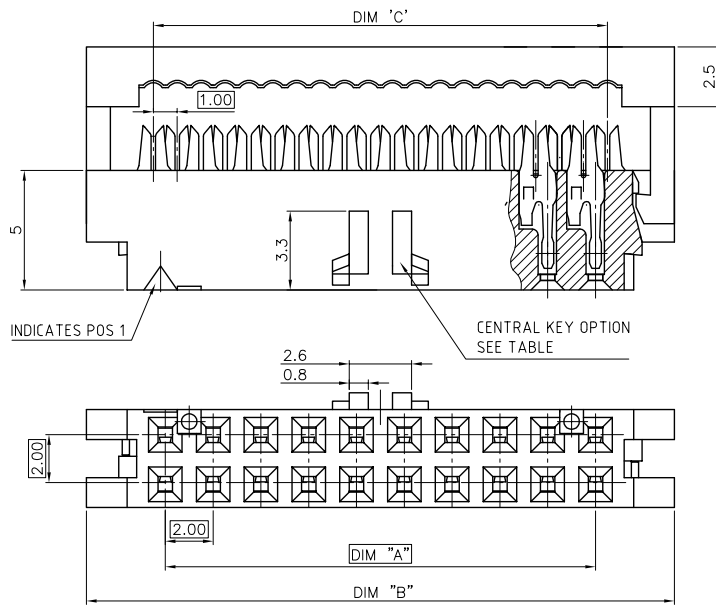

VIEW WITHOUT COVER

mat'l. code		surface	tolerance	projection	product family
SEE NOTE		ISO 1302	ISO 406 ISO 1101		MINITEK
Ltr	ec'n no	dr	date	tolerances unless otherwise specified	title
L	F06-0211	LMU	06.07.03	angles	2.00mm IDC
M	F07-0215	LMU	07.06.12	linear	0.76µm Au
N	F08-0214	J.CO	08.09.09	0°±'	mm
P	F09-0081	JCO	09.08.27	0.000±.05	scale 1:1
		dr	L.MULIN	07.03.20	
		engr	J.COMPAGNON	07.03.20	
		chr			
		app	J.M.C	07.03.20	dwg no
					89947
sheet	revision	P	P		type
index	sheet	1	2		Product Customer Drawing

PDM: Rev:P

STATUS:Released

Printed: Sep 01, 2009

PRODUCT NUMBER	TOTAL NB OF POS	DIM "A"	DIM "B"	DIM "C"	STRAIN RELIEF OPTION
89947-X06LF	2x3	4	10.6	5	YES
89947-X08LF	2x4	6	12.6	7	YES
89947-X10LF	2x5	8	14.6	9	YES
89947-X12LF	2x6	10	16.6	11	YES
89947-X14LF	2x7	12	18.6	13	YES
89947-X16LF	2x8	14	20.6	15	YES
89947-X18LF	2x9	16	22.6	17	YES
89947-X20LF	2x10	18	24.6	19	YES
89947-X22LF	2x11	20	26.6	21	NOT TOOLED
89947-X24LF	2x12	22	28.6	23	YES
89947-X26LF	2x13	24	30.6	25	YES
89947-X28LF	2x14	26	32.6	27	NOT TOOLED
89947-X30LF	2x15	28	34.6	29	YES
89947-X34LF	2x17	32	38.6	33	YES
89947-X36LF	2x18	34	40.6	35	NOT TOOLED
89947-X40LF	2x20	38	44.6	39	YES
89947-X44LF	2x22	42	48.6	43	YES
89947-X48LF	2x24	46	52.6	47	YES
89947-X50LF	2x25	48	54.6	49	YES

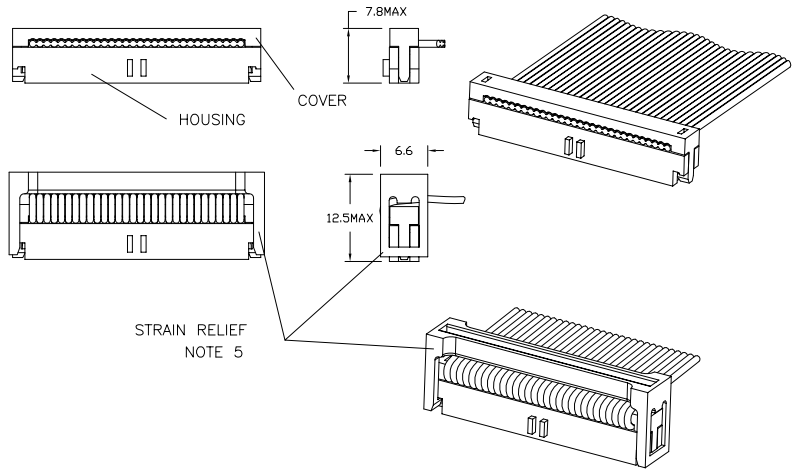

NOTES :

- MATERIAL : TERMINAL PHOSPHORE BRONZE
BASE AND COVER : PBT GLASSFILLED UL 94V-0 BLACK
- PLATING : GOLD 0.76µm Au MIN ON CONTACT AREA
NICKEL 1.27µm MIN UNDERPLATING ALL OVER
- RECOMMENDED CABLE SIZE : AWG28, STRANDED
- THIS PRODUCT MEETS EUROPEAN UNION DIRECTIVES AND OTHER COUNTRY REGULATIONS AS PER GS-22-008.
PACKAGING SPECIFICATION AS PER GS-14-920.
- S= STRAIN RELIEF ACCESSORY, SEE TABLE FOR AVAILABILITY,
OMIT LETTER FROM PARTNUMBER IF NOT APPLICABLE.

PRODUCT CODE	WITHOUT CENTRAL KEY	WITH CENTRAL KEY	WITH CENTRAL KEY AND FRICTION LATCH BUMP	AVAILABILITY
89947-7XX			○	FROM 2X3 POS UP TO 2X17
89947-3XX		○		FROM 2X17 POS UP TO 2X25
89947-1XX	○			FROM 2x3 POS UP TO 2x25

mat'l. code	surface	tolerance	projection	product family
SEE NOTE	ISO 1302 ✓	ISO 406 ISO 1101		MINITEK
Ltr	ecn no	dr	date	title
L	F06-0211	LMU	06.07.03	2.00mm IDC
M	F07-0215	LMU	07.06.12	0.76µm Au
N	F08-0214	JCO	08.09.09	
P	F09-0081	JCO	09.08.27	
engr	J.COMPAGNON		07.03.20	FCJ
chr				
appd	J.M.C		07.03.20	
sheet index	revision sheet			dwg no 89947 sheet 2 of 2 size A3
				type Product Customer Drawing