

PROPER USE GUIDELINES

Cumulative Trauma Disorders can result from the prolonged use of manually powered hand tools. Hand tools are intended for occasional use and low volume applications. A wide selection of powered application equipment for extended-use, production operations is available.

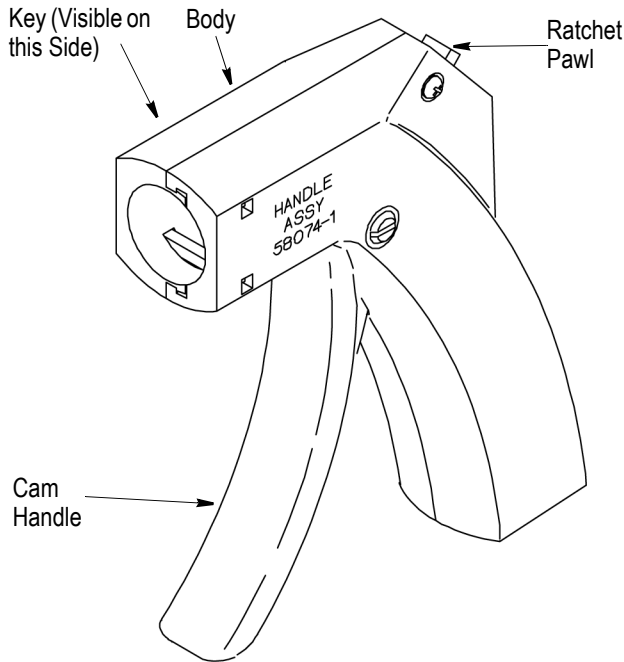

Figure 1

1. INTRODUCTION

Pistol Grip Manual Handle Assembly 58074-1 accepts interchangeable terminating heads that terminate wires to connectors. To ensure accurate termination of wires, setup adjustments, and head maintenance, refer to the instructions packaged with the terminating head.

NOTE *Dimensions in this instruction sheet are in metric units [with U.S. customary units in brackets]. Figures are not drawn to scale.*

Reasons for reissue of this instruction sheet are provided in Section 6, REVISION SUMMARY.

2. DESCRIPTION

The manual handle assembly features a cam handle, a key, and a ratchet pawl. The head is secured in the handle assembly with the key.

After the head is properly installed in the handle assembly, the cam handle actuates the terminating mechanism inside the head. The ratchet pawl is used to release the handle before it is fully closed.

NOTE *For details concerning the termination procedure, refer to the instructions included with the head.*

3. HEAD INSTALLATION AND REMOVAL

1. Position the blade tip of a screwdriver between the shoulder of the key and the handle assembly body. Pry and remove the key.
2. Squeeze the cam handle until the ratchet releases, then allow it to FULLY open.
3. Insert the terminating head into the head entrance until the head bottoms. See Figure 2.

NOTE *Make sure that the head is FULLY bottomed in the handle assembly before re-inserting the key.*

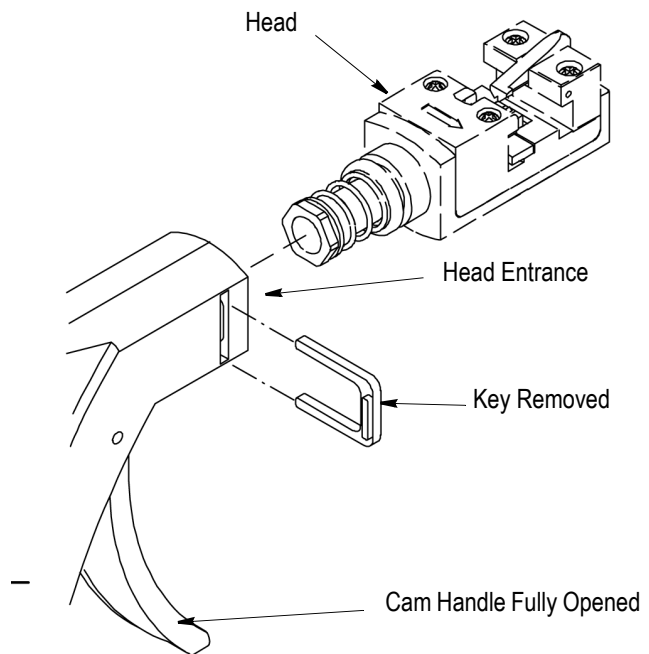

Figure 2

4. Re-insert the key to retain the head. Apply enough pressure to fully insert the key into the manual assembly.
5. To remove the head, remove the key and pull the head out of the handle assembly.

4. MAINTENANCE AND INSPECTION

It is recommended that a maintenance and inspection program be performed periodically to ensure dependable and uniform terminations. Though recommendations call for at least one inspection a month, frequency of inspection depends on:

1. The care, amount of use, and handling of the handle assembly.
2. The presence of abnormal amounts of dust and dirt.
3. The degree of operator skill.
4. Your own established standards.

The handle assembly is inspected before being shipped; however, it is recommended that the handle assembly be inspected immediately upon arrival to ensure that the handle assembly has not been damaged during shipment.

4.1. Daily Maintenance

Each operator should be aware of, and responsible for, the following:

1. Remove dust, moisture, and other contaminants with a clean brush, or soft, lint-free cloth. DO NOT use objects that could damage the handle assembly.
2. Ensure that all components are in place and properly secured.
3. With the terminating head in place, squeeze and release the cam handle to ensure that the mechanisms move smoothly.
4. Depress and release the spring-loaded ratchet pawl to ensure that the pawl moves freely.
5. Check the extension springs to ensure they are properly located and are not deformed.

4.2. Periodic Inspection

1. Remove any accumulated film with a suitable cleaning agent that will not affect plastic material.
2. Make sure all components are in place and are properly secured. Check the handle assembly for chipped, cracked, worn, or broken areas. If damage is evident, repair is necessary. See Section 6, REPLACEMENT AND REPAIR.

5. REPLACEMENT AND REPAIR

Customer-replaceable parts are listed in Figure 3.

A complete inventory can be stocked and controlled to prevent lost time when replacement of parts is necessary. Parts other than those listed should be replaced by Tyco Electronics Corporation to ensure quality and reliability of the handle assembly. Order replacement parts through your representative, or call 1-800-526-5142, or send a facsimile of your purchase to 717-986-7605, or write to:

CUSTOMER SERVICE (038-035)
TYCO ELECTRONICS CORPORATION
PO BOX 3608
HARRISBURG PA 17105-3608

For customer repair service, call 1-800-526-5136.

6. REVISION SUMMARY

Since the previous release of this instruction sheet, the new company logo has been applied.

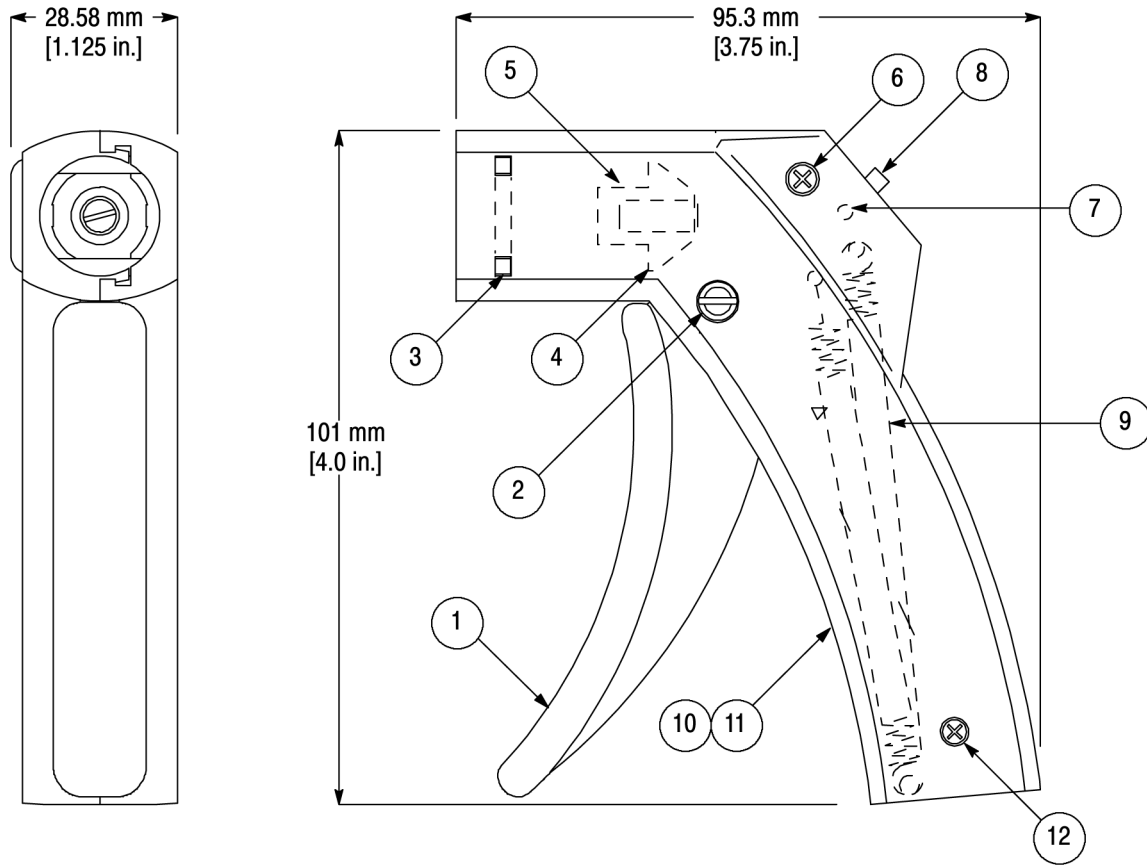

REPLACEMENT PARTS

ITEM	PART NUMBER	DESCRIPTION	QTY PER ASSY
1	312145-1	HANDLE, Cam	1
2	1-22353-2	SCREW, Slot Head Shoulder	1
3	312140-1	KEY	1
4	312141-1	NUT, Cam Adjustment	1
5	312142-1	SCREW, Ratchet Adjustment	1
6	28593-1	SCREW, Self-Tapping	1
7	1-21919-2	PIN, Dowel	1
8	312143-1	PAWL, Ratchet	1
9	22286-9	SPRING, Extension	2
10	312144-1	HANDLE, Right	1
11	312144-2	HANDLE, Left	1
12	28593-3	SCREW, Self-Tapping, .22 X .62 In. L	1

Figure 3