

THIS INFORMATION IS CONFIDENTIAL AND IS DISCLOSED TO YOU ON CONDITION THAT NO FURTHER DISCLOSURE IS MADE BY YOU TO OTHER THAN AMP PERSONNEL WITHOUT WRITTEN AUTHORIZATION FROM AMP INCORPORATED, HARRISBURG, PA.

608651

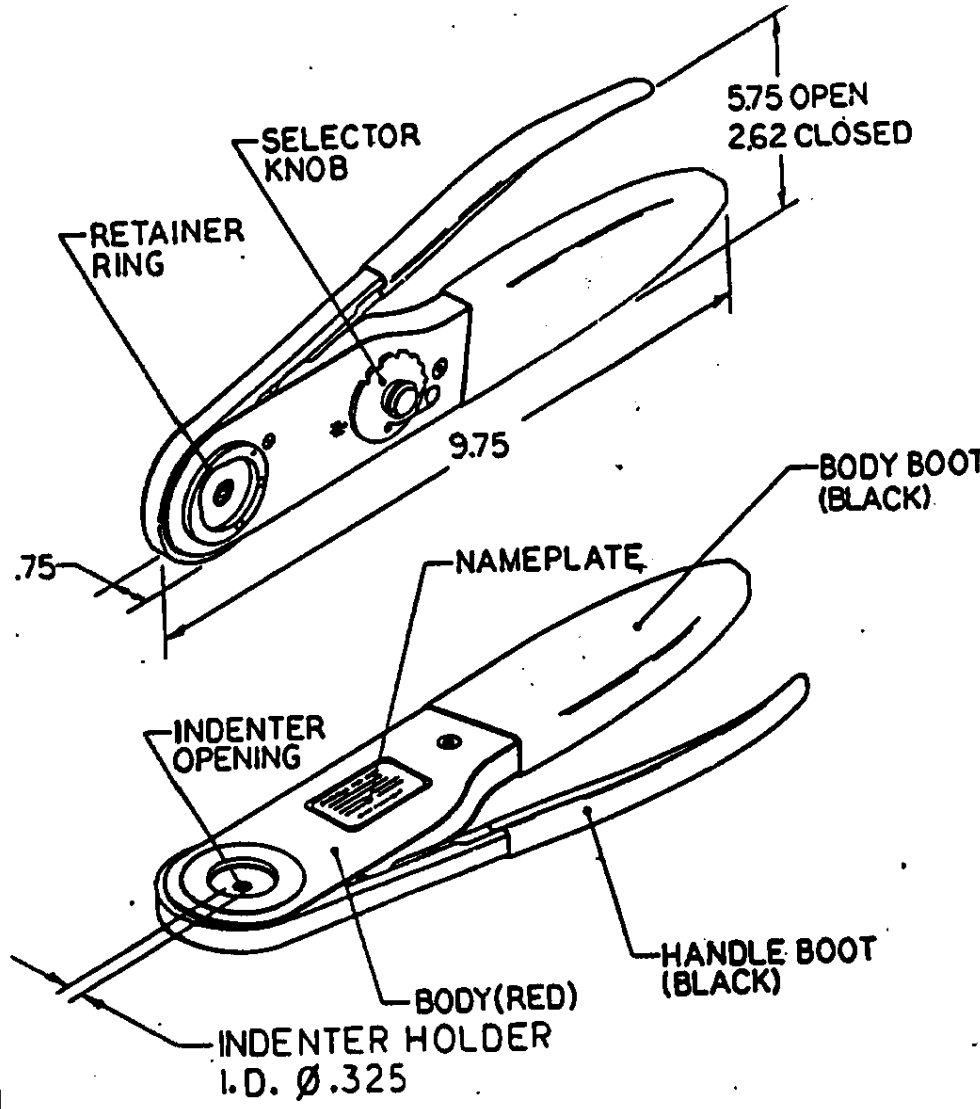

GAGING LIMITS		
SEL.#	GO	NO-GO
8	.118	.128
7	.108	.118
6	.099	.109
5	.092	.102
4	.085	.095
3	.080	.090
2	.075	.085
1	.070	.080

AMP ENGINEERING  
JUN 1989  
Ocu

CUSTOMER DRAWING  
UNPUBLISHED

608651-1

AS SHOWN

LOC D	DWG SIZE		PART NO		DESCRIPTION		ITEM NO
DIST 1	← REVISION OF EACH ASSY NO (WHEN BLANK, USE DWG REVISION)						
QTY REQD PER ASSY			PARTS LIST				
			MATERIAL	HEAT TREAT	FINISH		
			DIMENSIONS IN INCHES. TOLERANCES UNLESS OTHERWISE SPECIFIED: 2 PL DEC ± .02 3 PL DEC ± .010 4 PL DEC ± — ANGLES ± — SURF TEXTURE: ✓	DR Ray J. 12-14-89 CHK	APP Ray Johnston 12-14-89 REL F. HARRIS 12-14-89		
A ECN 60590			7mm 6-90		AMP INCORPORATED Harrisburg, Pa.		
O RELEASED 12-14-89			R.J. 12-89		NAME <b>FRAME, HAND TOOL,</b>		
P	F	LTR	REVISION RECORD	APP	DATE	SCALE NTS	DWG NO A
						608651-1	SHEET A