

**PROPER USE GUIDELINES**

Cumulative Trauma Disorders can result from the prolonged use of manually powered hand tools. Hand tools are intended for occasional use and low volume applications. A wide selection of powered application equipment for extended-use, production operations is available.

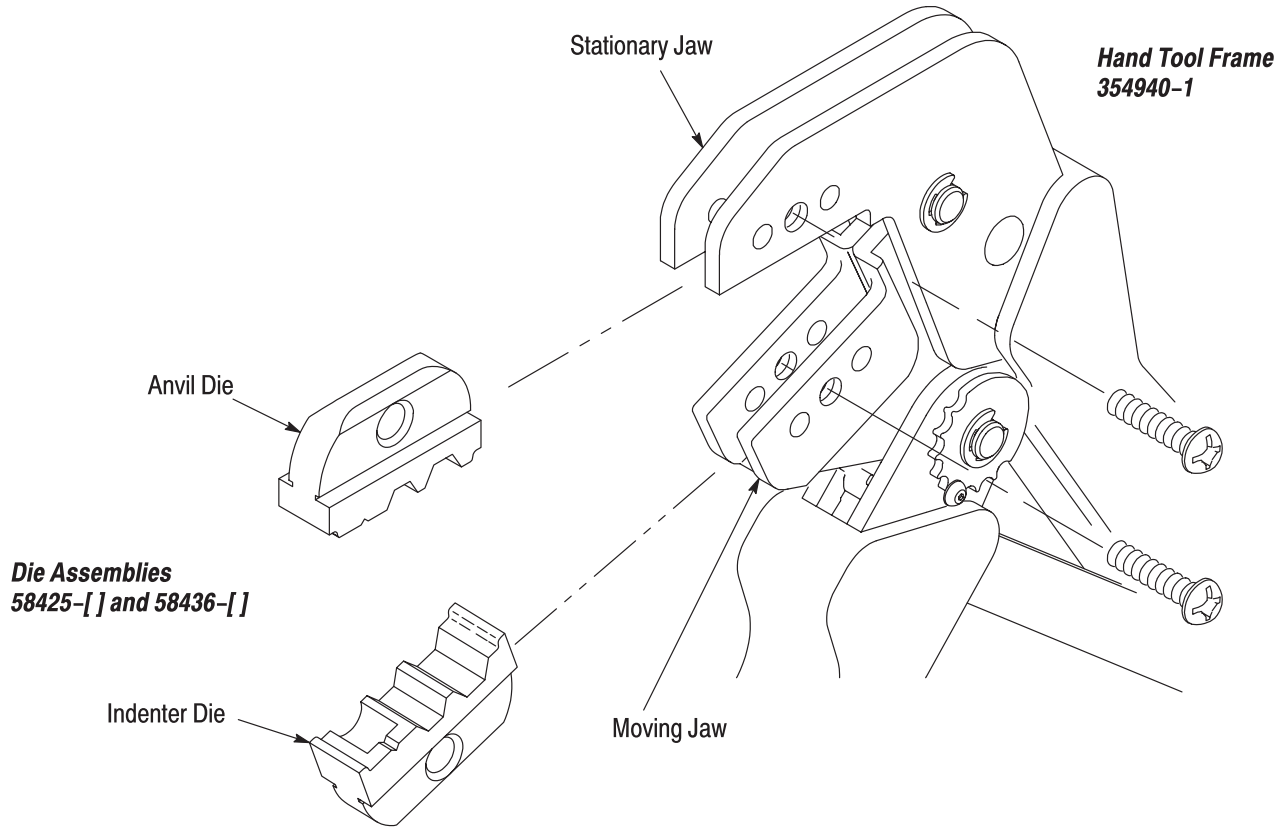

Figure 1

**1. INTRODUCTION**

This instruction sheet covers the use and maintenance of Crimping Dies 58425-[ ] and 58436-[ ] (in their various configurations – denoted by the dash number following the base part number), used in PRO-CRIMPER\* Hand Tool Frame 354940-1. The dies crimp 75-Ohm Hex Crimp BNC and TNC plug connectors onto coaxial cable.

Reasons for reissue of this sheet are provided in Section 7, REVISION SUMMARY.

**NOTE**

*All dimensions are in millimeters [with inches in brackets]. Figures and illustrations are for reference only and are not drawn to scale.*

**2. DESCRIPTION (Figure 1)**

Each die assembly consists of an indenter die and an anvil die. When closed, the dies form either two or three crimping chambers (depending on type) which crimp the center contact and ferrule of the connector onto the coaxial cable. Each die is held in the tool by a single screw.

**3. DIE INSTALLATION**

1. Close the tool handles until the ratchet releases and then allow them to open fully.
2. See Figure 1 for normal orientation of the dies. Insert the dies inside the tool jaws and align the retaining screw holes.
3. Thread the retaining screws into the holes and carefully close the tool handles. Tighten the screws with the appropriate hex wrench.

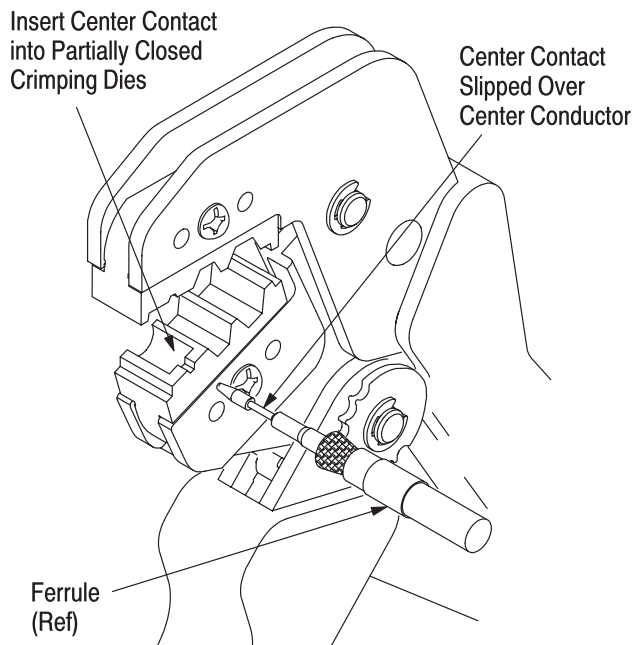

Figure 2

## 4. CRIMPING PROCEDURE

### 4.1. Center Contact

1. Prepare the connector and the cable according to the instructions packaged with the connector.
2. Slide the center contact onto the center conductor of the cable; then insert the contact assembly into the center contact crimp section of the die. See Figure 2.

#### NOTE



Make sure that the flange on the end of the center contact butts against the crimping die. See Figure 3.

3. Crimp the center contact by holding the cable in place; then close the tool handles until the ratchet releases.

### 4.2. Ferrule

1. Insert the crimped center contact into the connector body until the cable dielectric butts against the dielectric inside of the connector body. The flared braid will then fit around the support sleeve of the connector body.
2. Slide the ferrule forward over the braid until the ferrule butts against the shoulder on the connector body.
3. Place the ferrule on the appropriate anvil of the die assembly so that the shoulder on the connector body is butted against the die. See Figure 4.
4. Holding the assembly in place, close the tool handles until the ratchet releases.

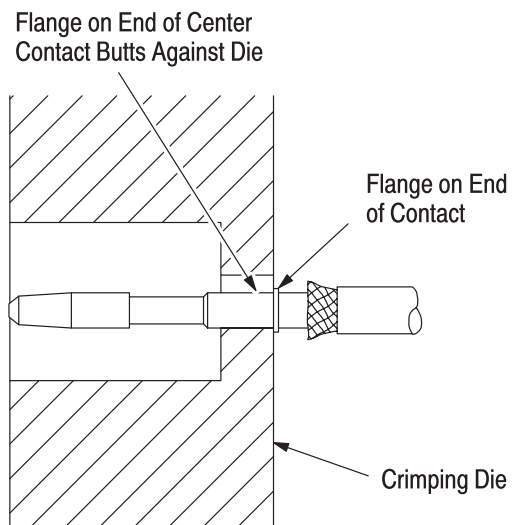

Figure 3

#### CAUTION



Damaged product should not be used. If a damaged contact or ferrule is evident, it should be cut from the wire and replaced with a new one. Do NOT reterminated contact or ferrules.

## 5. INSPECTION

### 5.1. Visual Inspection

Inspection of the crimping dies should be made on a regular basis to ensure that they have not become worn or damaged. Inspect the crimp sections for flattened, chipped, worn, or broken areas. If damage or abnormal wear is evident, the dies must be replaced. Refer to Section 6, PARTS REPLACEMENT.

#### Crimping Ferrule

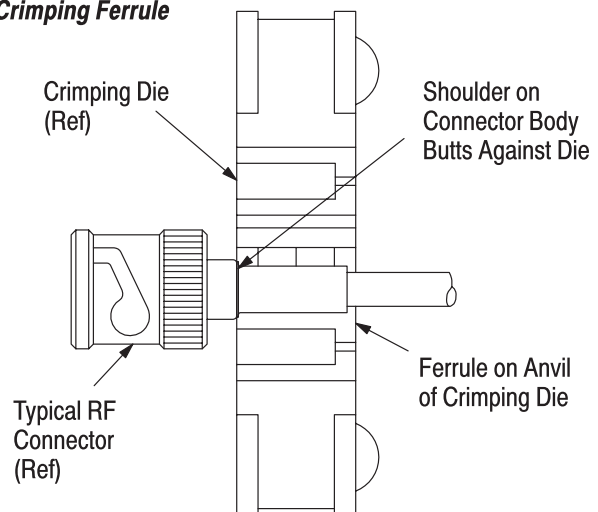
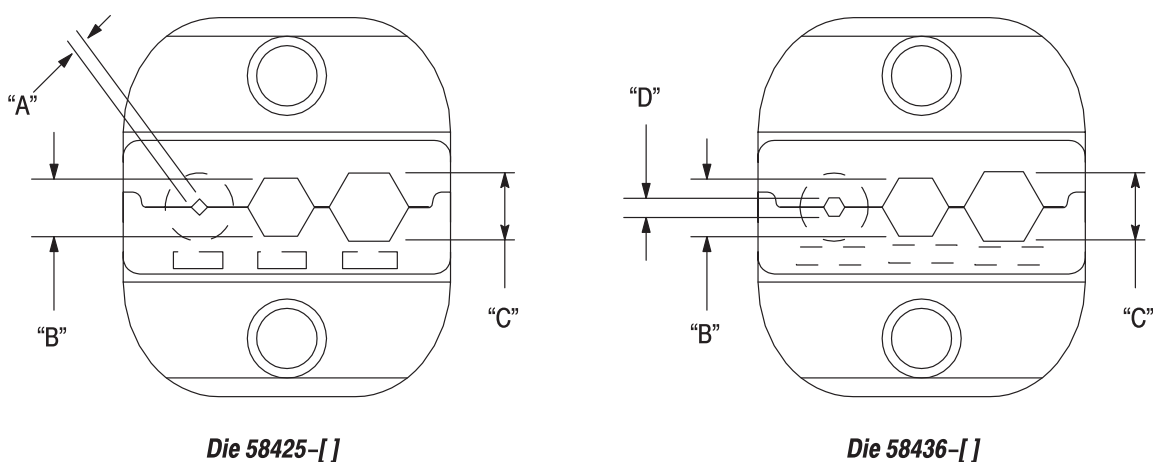

Figure 4



| DIE ASSEMBLY PART NUMBER | CHAMBER CRIMP DIMENSION $\pm 0.10$ [.004] |                   |                   |                   |
|--------------------------|---|-------------------|-------------------|-------------------|
|                          | "A"                                       | "B"               | "C"               | "D"               |
| 58425-1                  | 1.07 [.042] (Square)                      | 5.41 [.213] (Hex) | 6.48 [.255] (Hex) | ---               |
| 58425-2                  | 1.07 [.042] (Square)                      | 3.25 [.128] (Hex) | 4.52 [.178] (Hex) | ---               |
| 58425-3                  | 1.07 [.042] (Square)                      | 3.84 [.151] (Hex) | 8.23 [.324] (Hex) | ---               |
| 58436-1                  | ---                                       | 5.41 [.213] (Hex) | 6.48 [.255] (Hex) | 1.73 [.068] (Hex) |
| 58436-2                  | ---                                       | 2.54 [.100] (Hex) | 8.23 [.324] (Hex) | 1.73 [.068] (Hex) |
| 58436-3                  | ---                                       | 3.84 [.151] (Hex) | 4.52 [.178] (Hex) | 1.73 [.068] (Hex) |
| 58436-4                  | ---                                       | 3.73 [.147] (Hex) | 4.52 [.178] (Hex) | 1.73 [.068] (Hex) |

Figure 5

## 5.2. Measuring Die Opening

The die assembly will perform correctly as long as: (1) the product specified is correct for the application, (2) the specific die assembly is used, (3) the die assembly has been measured to ensure that the openings are correct, and (4) the tool has been adjusted correctly.

Figure 5 provides information on die opening sizes.

## 5.3. Ratchet Adjustment

The tool frame assembly ratchet mechanism features an adjustment wheel with eight settings. The adjustment wheel controls the amount of handle pressure exerted on the tool jaws and crimping dies during crimping. If the crimp is not acceptable, adjust the ratchet as follows:

1. Sufficiently loosen the screw at the ratchet adjustment wheel so that the wheel can be rotated above the post that engages the teeth in the wheel.
2. If the crimp is too loose, turn the wheel to a higher notch (for example, if the wheel is set at notch no. 5, move the wheel to notch no. 6). If the crimp is too tight, move the wheel to a lower notch.
3. Tighten the screw at the ratchet adjustment wheel.

If the crimp cannot be made to conform to the dimensions provided in the appropriate product application specification, the tool and/or dies are defective and must be replaced.

### NOTE



Other dies of the PRO-CRIMPER hand tool series may be used in this tool; however, the ratchet adjustment wheel may require adjustment to achieve acceptable crimp height.

## 6. PARTS REPLACEMENT

Customer-replaceable parts are shown in Figure 1. Available separately, PRO-CRIMPER Repair Kit 679221-1 includes a variety of pins, rings, screws, and springs. If the dies are damaged or worn excessively, they must be replaced. Order the repair kit and replaceable parts through your Tyco Electronics Representative, or call 1-800-526-5142, or send a facsimile of your purchase order to 1-717-986-7605, or write to:

CUSTOMER SERVICE (38-35)  
TYCO ELECTRONICS CORPORATION  
P.O. BOX 3608  
HARRISBURG, PA 17105-3608

## 7. REVISION SUMMARY

- Updated logo and format.