

Key Features:

- Economical single primary 115 VAC, 60 Hz. (or 117 50/60 Hz. see table) - (If you require 117/234 or 50/60 Hz. operation or dual secondaries check out our versatile [266 series](#))
- All secondaries center tapped, VAC (RMS)
- Open style, channel bracket, two hole chassis mount.
- Minimum 6" long leads.
- Dual bobbin design - no electrostatic shield required.
- We use Class B insulation (130 degrees, C) for extra protection - UL listed as a Class A (105 degree, C) design
- Hi-Pot test of 2,000V RMS.
- UL listed.
- CSA certified.

Part No.	VA	Primary (VAC)	Secondary (R.M.S.)		Dim. Ref.
			VAC	Amps	
166F2	0.63	115V 60 Hz.	2.5 C.T.	0.25	C2H
166G2	1.25	115V 60 Hz.	2.5 C.T.	0.5	C2H
166J2	2.5	115V 60 Hz.	2.5 C.T.	1	C3H
166K2	3.75	115V 60 Hz.	2.5 C.T.	1.5	C4H
166L2	6.25	115V 60 Hz.	2.5 C.T.	2.5	C6H
166M2	7.5	115V 60 Hz.	2.5 C.T.	3	C6H
166Q2	15	115V 60 Hz.	2.5 C.T.	6	C8H
166S2	25	115V 60 Hz.	2.5 C.T.	10	C12H
166F5	1.25	115V 60 Hz.	5 C.T.	0.25	C2H
166G5	2.5	115V 60 Hz.	5 C.T.	0.5	C3H
166J5	5	115V 60 Hz.	5 C.T.	1	C5H
166L5	10	115V 60 Hz.	5 C.T.	2	C7H
166MS	15	115V 60 Hz.	5 C.T.	3	C9H
166R5	40	115V 60 Hz.	5 C.T.	8	C12H
166RS	40	115V 60 Hz.	5 C.T.	8	C16H

166L25B	50.4	115V 50/60 Hz.	25.2 C.T.	2	C14H
166F28	7	115V 60 Hz.	28 C.T.	0.25	C6H
166G28	14	115V 60 Hz.	28 C.T.	0.5	C7H
166J28	28	115V 60 Hz.	28 C.T.	1	C10H
166L28	56	115V 60 Hz.	28 C.T.	2	C13H
166E30	4.5	115V 60 Hz.	30 C.T.	0.15	C4H
166F30	7.5	115V 60 Hz.	30 C.T.	0.25	C6H
166G30	15	115V 60 Hz.	30 C.T.	0.5	C8H
166J33	33	115V 60 Hz.	33 C.T.	1	C10H
166K35	52.5	115V 60 Hz.	35 C.T.	1.5	C13H
166E36	5.4	115V 60 Hz.	36 C.T.	0.15	C5H
166F36	10.8	115V 60 Hz.	36 C.T.	0.3	C7H
166G36	18	115V 60 Hz.	36 C.T.	0.5	C8H
166J36	36	115V 60 Hz.	36 C.T.	1	C11H
166L42	84	115V 60 Hz.	42 C.T.	2	C15H
166E44	6.6	115V 60 Hz.	44 C.T.	0.15	C6H
166F44	11	115V 60 Hz.	44 C.T.	0.25	C7H
166G44	22	115V 60 Hz.	44 C.T.	0.5	C9H
166J44	44	115V 60 Hz.	44 C.T.	1	C12H
166M48	144	117V 50/60 Hz.	48 C.T.	3	B1H
166C50	3.75	115V 60 Hz.	50 C.T.	0.075	C4H
166F50	15	115V 60 Hz.	50 C.T.	0.3	C8H
166G50	25	115V 60 Hz.	50 C.T.	0.5	C9H
166J50	50	115V 60 Hz.	50 C.T.	1	C13H
166L50	100	115V 60 Hz.	50 C.T.	2	C16H
166G60	30	115V 60 Hz.	60 C.T.	0.5	C10H
166M72	216	117V 50/60 Hz.	72 C.T.	3	B2H
166G80	40	115V 60 Hz.	80 C.T.	0.5	C11H
166G100	50	115V 60 Hz.	100 C.T.	0.5	C13H
166F120	36	115V 60 Hz.	120 C.T.	0.3	C11H

Filament & L.V. Rectifier Use - Single Primary (166 Series)

Power

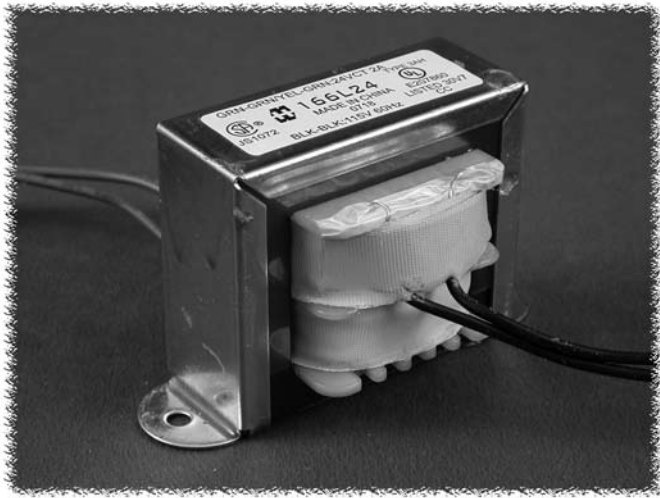

OPEN STYLE FILAMENT & L.V. RECTIFIER USE TRANSFORMERS

- Economical single primary 115 VAC, 60 Hz. or 117 VAC, 50/60 Hz. (see tables). If you require dual primary 117/234 operation, see our 266 series)
- All secondaries center tapped, VAC (RMS)
- Open style, channel bracket, two hole chassis mount.
- Minimum 6" long leads.
- Dual bobbin design - no electrostatic shield required.
- We use Class B insulation (130 degrees, C) for extra protection - UL listed as a Class A (105 degree, C) design.
- Hi-Pot test of 2,000V RMS.
- UL listed.
- CSA certified.

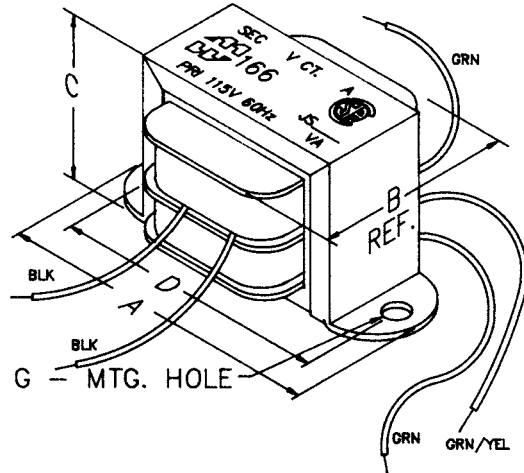

Dimension Table "C" Mount

Mtg. Style	Dimensions (Inches)				Mtg. Hole (Inches)
	A	B	C	D	
C0H	1.35	0.69	0.69	1.06	0.125
C1H	1.63	0.88	0.81	1.38	0.125
C2H	2.06	1.25	1.19	1.75	0.187
C3H	2.06	1.38	1.19	1.75	0.187
C4H	2.38	1.38	1.38	2.00	0.187
C5H	2.38	1.50	1.38	2.00	0.187
C6H	2.81	1.50	1.69	2.38	0.187
C7H	2.81	1.63	1.69	2.38	0.187
C8H	3.25	1.63	2.00	2.81	0.187
C9H	3.25	1.75	2.00	2.81	0.187
C10H	3.25	2.00	2.00	2.81	0.187
C11H	3.69	1.88	2.31	3.13	0.187
C12H	3.69	2.00	2.31	3.13	0.187
C13H	3.69	2.13	2.31	3.13	0.187
C14H	4.03	2.25	2.63	3.56	0.187
C15H	4.03	2.50	2.63	3.56	0.187
C16H	4.50	2.50	3.00	4.00	0.203

Transformer Schematic

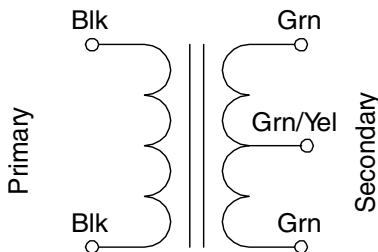

Filament & L.V. Rectifier Use - Single Primary (166 Series)

Power

Part No.	VA	Primary	Secondary (R.M.S.)		Dim Ref.	Part No.	VA	Primary	Secondary (R.M.S.)		Dim Ref.
			VAC	Amps					VAC	Amps	
166F2	0.63	115 V 60 Hz.	2.5 C.T.	0.25	C2H	166LA12	24	115 V 60 Hz.	12 C.T.	2	C9H
166G2	1.25	115 V 60 Hz.	2.5 C.T.	0.5	C2H	166N12B	48	117 V 50/60 Hz.	12 C.T.	4	C12H
166J2	2.5	115 V 60 Hz.	2.5 C.T.	1	C3H	166F12	3.78	115 V 60 Hz.	12.6 C.T.	0.3	C4H
166K2	3.75	115 V 60 Hz.	2.5 C.T.	1.5	C4H	166G12	6.3	115 V 60 Hz.	12.6 C.T.	0.5	C6H
166L2	6.25	115 V 60 Hz.	2.5 C.T.	2.5	C6H	166J12	12.6	115 V 60 Hz.	12.6 C.T.	1	C7H
166M2	7.5	115 V 60 Hz.	2.5 C.T.	3	C6H	166K12B	18.9	117 V 50/60 Hz.	12.6 C.T.	1.5	C10H
166Q2	15	115 V 60 Hz.	2.5 C.T.	6	C8H	166L12B	25.2	117 V 50/60 Hz.	12.6 C.T.	2	C10H
166S2	25	115 V 60 Hz.	2.5 C.T.	10	C12H	166L12	31.5	115 V 60 Hz.	12.6 C.T.	2.5	C10H
166F5	1.25	115 V 60 Hz.	5 C.T.	0.25	C2H	166M12	37.8	117 V 50/60 Hz.	12.6 C.T.	3	C13H
166G5	2.5	115 V 60 Hz.	5 C.T.	0.5	C3H	166N12	50.4	115 V 60 Hz.	12.6 C.T.	4	C13H
166J5	5	115 V 60 Hz.	5 C.T.	1	C5H	166Q12	75.6	115 V 60 Hz.	12.6 C.T.	6	C14H
166L5	10	115 V 60 Hz.	5 C.T.	2	C7H	166R12	100.8	115 V 60 Hz.	12.6 C.T.	8	C16H
166MS	15	115 V 60 Hz.	5 C.T.	3	C9H	166E14	2.1	115 V 60 Hz.	14 C.T.	0.15	C3H
166R5	40	115 V 60 Hz.	5 C.T.	8	C12H	166G14	7	115 V 60 Hz.	14 C.T.	0.5	C6H
166RS	40	115 V 60 Hz.	5 C.T.	8	C16H	166J14	14	115 V 60 Hz.	14 C.T.	1	C7H
166S5	50	115 V 60 Hz.	5 C.T.	10	C13H	166L14	28	115 V 60 Hz.	14 C.T.	2	C10H
166U5	75	115 V 60 Hz.	5 C.T.	15	C14H	166Q14	84	115 V 60 Hz.	14 C.T.	6	C15H
166V5	100	115 V 60 Hz.	5 C.T.	20	C16H	166F16	4	115 V 60 Hz.	16 C.T.	0.25	C4H
166E6	0.95	115 V 60 Hz.	6.3 C.T.	0.15	C2H	166G16	8	115 V 60 Hz.	16 C.T.	0.50	C6H
166F6	1.89	115 V 60 Hz.	6.3 C.T.	0.3	C3H	166J16	16	115 V 60 Hz.	16 C.T.	1	C8H
166G6	3.78	115 V 60 Hz.	6.3 C.T.	0.6	C4H	166L16	35.2	115 V 60 Hz.	16 C.T.	2.2	C10H
166J6	6.3	115 V 60 Hz.	6.3 C.T.	1	C6H	166M16	48	115 V 60 Hz.	16 C.T.	3	C13H
166K6	7.56	115 V 60 Hz.	6.3 C.T.	1.2	C6H	166B18	0.54	115 V 60 Hz.	9/18 C.T.	.06/.03	C2H
166K6B	7.56	117 V 50/60 Hz.	6.3 C.T.	1.2	C6H	166E18	5.4	115 V 60 Hz.	18 C.T.	0.3	C5H
166L6	12.6	115 V 60 Hz.	6.3 C.T.	2	C7H	166K18	27	115 V 60 Hz.	18 C.T.	1.5	C9H
166M6	18.9	117 V 50/60 Hz.	6.3 C.T.	3	C10H	166M18	54	115 V 60 Hz.	18 C.T.	3	C13H
166N6	25.2	115 V 60 Hz.	6.3 C.T.	4	C9H	166P18	90	115 V 60 Hz.	18 C.T.	5	C15H
166Q6	37.8	115 V 60 Hz.	6.3 C.T.	6	C12H	166D20	2	115 V 60 Hz.	20 C.T.	0.1	C3H
166S6	63	115 V 60 Hz.	6.3 C.T.	10	C14H	166E20	3	115 V 60 Hz.	20 C.T.	0.15	C3H
166G7	4.9	115 V 60 Hz.	7 C.T.	0.7	C5H	166F20	6	115 V 60 Hz.	20 C.T.	0.3	C5H
166U7	112.5	115 V 60 Hz.	7.5 C.T.	15	C16H	166G20	10	115 V 60 Hz.	20 C.T.	0.5	C7H
166G8	4	115 V 60 Hz.	8 C.T.	0.5	C4H	166J20	20	115 V 60 Hz.	20 C.T.	1	C9H
166J8	8.5	115 V 60 Hz.	8.5 C.T.	1	C6H	166L20	40	115 V 60 Hz.	20 C.T.	2	C11H
166L8	17	115 V 60 Hz.	8.5 C.T.	2	C8H	166L22	44	115 V 60 Hz.	22 C.T.	2	C13H
166M8	25.5	115 V 60 Hz.	8.5 C.T.	3	C9H	166A24	0.63	115 V 60 Hz.	12.6/25.2 C.T.	.05/.025	C2H
166N8	34	115 V 60 Hz.	8.5 C.T.	4	C10H	166C24	2.04	115 V 60 Hz.	24 C.T.	0.085	C3H
166G9	4.5	115 V 60 Hz.	9 C.T.	0.5	C4H	166EA24	4.8	115 V 60 Hz.	24 C.T.	0.2	C5H
166F10	3	115 V 60 Hz.	10 C.T.	0.3	C3H	166FB24	9.6	117 V 50/60 Hz.	24 C.T.	0.4	C7H
166G10	5	115 V 60 Hz.	10 C.T.	0.5	C5H	166GD24B	16.8	117 V 50/60 Hz.	24 C.T.	0.7	C9H
166J10	10	115 V 60 Hz.	10 C.T.	1	C7H	166J24	24	117 V 50/60 Hz.	24 C.T.	1	C10H
166L10	20	115 V 60 Hz.	10 C.T.	2	C9H	166JB24	24	115 V 60 Hz.	24 C.T.	1	C9H
166M10	30	115 V 60 Hz.	10 C.T.	3	C10H	166L24	48	115 V 60 Hz.	24 C.T.	2	C13H
166N10	40	115 V 60 Hz.	10 C.T.	4	C12H	166M24	72	115 V 60 Hz.	24 C.T.	3	C14H
166P10	50	115 V 60 Hz.	10 C.T.	5	C13H	166N24	96	115 V 60 Hz.	24 C.T.	4	C16H
166R10	80	115 V 60 Hz.	10 C.T.	8	C15H	166D25	2.5	115 V 60 Hz.	25 C.T.	0.1	C3H
166S10	100	115 V 60 Hz.	10 C.T.	10	C16H	166E25	3.75	115 V 60 Hz.	25 C.T.	0.15	C4H
166P11	55	115 V 60 Hz.	11 C.T.	5	C13H	166F25	7.5	115 V 60 Hz.	25 C.T.	0.3	C6H
166S11	110	115 V 60 Hz.	11 C.T.	10	C16H	166G25	12.5	115 V 60 Hz.	25 C.T.	0.5	C7H
166C12	0.63	115 V 60 Hz.	6.3/12.6 C.T.	.1/.05	C2H	166J25	25	115 V 60 Hz.	25 C.T.	1	C9H
166E12	1.8	115 V 60 Hz.	12 C.T.	0.15	C3H	166J25B	25	117 V 50/60 Hz.	25 C.T.	1	C10H
166F12B	3.6	115 V 60 Hz.	12 C.T.	0.3	C4H	166K25	37.5	115 V 60 Hz.	25 C.T.	1.5	C11H
166F12C	4.2	115 V 60 Hz.	12 C.T.	0.35	C4H	166L25	50	115 V 60 Hz.	25 C.T.	2	C13H
166GD12	8.4	117 V 50/60 Hz.	12	0.7	C7H	166M25	75	115 V 60 Hz.	25 C.T.	3	C14H
166JA12	12	115 V 60 Hz.	12 C.T.	1	C7H	166L25B	50.4	115 V 50/60 Hz.	25.2 C.T.	2	C14H
166K12	14.4	115 V 60 Hz.	12 C.T.	1.2	C8H	166F28	7	115 V 60 Hz.	28 C.T.	0.25	C6H
166JB12	14.4	117 V 50/60 Hz.	12 C.T.	1.2	C9H	166G28	14	115 V 60 Hz.	28 C.T.	0.5	C7H



Filament & L.V. Rectifier Use - Single Primary (166 Series)

Power

Part No.	VA	Primary	Secondary (R.M.S.)		Dim Ref.
			VAC	Amps	
166J28	28	115 V 60 Hz.	28 C.T.	1	C10H
166L28	56	115 V 60 Hz.	28 C.T.	2	C13H
166E30	4.5	115 V 60 Hz.	30 C.T.	0.15	C4H
166F30	7.5	115 V 60 Hz.	30 C.T.	0.25	C6H
166G30	15	115 V 60 Hz.	30 C.T.	0.5	C8H
166J33	33	115 V 60 Hz.	33 C.T.	1	C10H
166K35	52.5	115 V 60 Hz.	35 C.T.	1.5	C13H
166E36	5.4	115 V 60 Hz.	36 C.T.	0.15	C5H
166F36	10.8	115 V 60 Hz.	36 C.T.	0.3	C7H
166G36	18	115 V 60 Hz.	36 C.T.	0.5	C8H
166J36	36	115 V 60 Hz.	36 C.T.	1	C11H
166L42	84	115 V 60 Hz.	42 C.T.	2	C15H
166E44	6.6	115 V 60 Hz.	44 C.T.	0.15	C6H
166F44	11	115 V 60 Hz.	44 C.T.	0.25	C7H
166G44	22	115 V 60 Hz.	44 C.T.	0.5	C9H
166J44	44	115 V 60 Hz.	44 C.T.	1	C12H
166M48	144	117 V 50/60 Hz.	48 C.T.	3	B1H
166C50	3.75	115 V 60 Hz.	50 C.T.	0.075	C4H
166F50	15	115 V 60 Hz.	50 C.T.	0.3	C8H
166G50	25	115 V 60 Hz.	50 C.T.	0.5	C9H
166J50	50	115 V 60 Hz.	50 C.T.	1	C13H
166L50	100	115 V 60 Hz.	50 C.T.	2	C16H
166G60	30	115 V 60 Hz.	60 C.T.	0.5	C10H
166M72	216	117 V 50/60 Hz.	72 C.T.	3	B2H
166G80	40	115 V 60 Hz.	80 C.T.	0.5	C11H
166G100	50	115 V 60 Hz.	100 C.T.	0.5	C13H
166F120	36	115 V 60 Hz.	120 C.T.	0.3	C11H

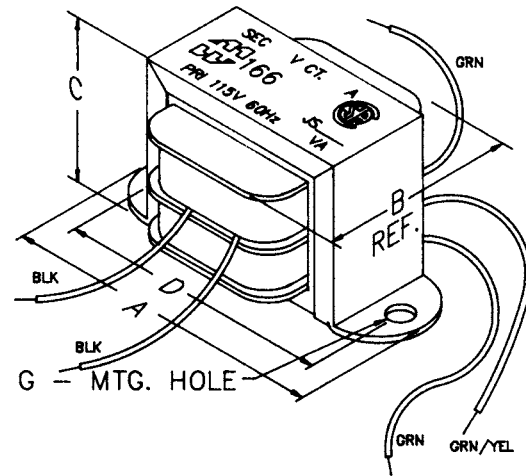

Dimension Table "C" Mount

Mtg. Style	Dimensions (Inches)				Mtg. Hole (Inches)
	A	B	C	D	
C0H	1.35	0.69	0.69	1.06	0.125
C1H	1.63	0.88	0.81	1.38	0.125
C2H	2.06	1.25	1.19	1.75	0.187
C3H	2.06	1.38	1.19	1.75	0.187
C4H	2.38	1.38	1.38	2.00	0.187
C5H	2.38	1.50	1.38	2.00	0.187
C6H	2.81	1.50	1.69	2.38	0.187
C7H	2.81	1.63	1.69	2.38	0.187
C8H	3.25	1.63	2.00	2.81	0.187
C9H	3.25	1.75	2.00	2.81	0.187
C10H	3.25	2.00	2.00	2.81	0.187
C11H	3.69	1.88	2.31	3.13	0.187
C12H	3.69	2.00	2.31	3.13	0.187
C13H	3.69	2.13	2.31	3.13	0.187
C14H	4.03	2.25	2.63	3.56	0.187
C15H	4.03	2.50	2.63	3.56	0.187
C16H	4.50	2.50	3.00	4.00	0.203

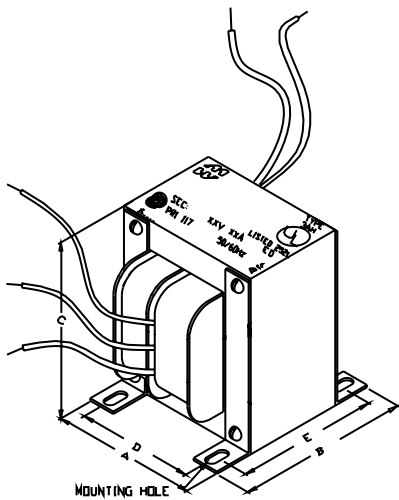

Dimension Table "B" Mount

Mtg. Style	Dimensions (Inches)					Mtg. Slot (Inches)
	A	B	C	D	E	
B1H	3.44	2.98	4.13	2.75	2.38	0.203 x 0.375
B2H	3.75	3.56	4.50	3.00	3.00	0.203 x 0.375

