

PART NUMBER	ITEM ① BODY	ITEM ② SLIDER	ITEM ③ CONTACT	ITEM ④ INSULATOR	ITEM ⑤ RETENTION SPRINGS	ITEM ⑥ COUPLING NUT
142-1901-821	BRASS GOLD PL .00001 MIN OVER NICKEL PL .00005 MIN OVER COPPER PL .00005 MIN	BRASS NICKEL PL .00005 MIN OVER COPPER PL .00005 MIN	BERYLLIUM COPPER GOLD PL .00005 MIN OVER NICKEL PL .00005 MIN OVER COPPER PL .00005 MIN	TEFLON	BERYLLIUM COPPER UNPLATED	BERYLLIUM COPPER NICKEL PL .0001 MIN OVER COPPER PL .00005 MIN

DRAWING NO. C - 142 - 1901 - 821 / 830	
0	REVISIONS
ENGINEERING RELEASE	
1	5-18-04
4-29-04	ECN 49278

**INSTRUCTIONS FOR USE:**

1. WITH SLIDER IN THE ENGAGED POSITION THE CONNECTOR FUNCTIONS LIKE A STANDARD SMA CONNECTOR. TIGHTEN (SPIN) THE KNURLED NUT BY HAND TO OBTAIN FULL MATING ENGAGEMENT OR DISENGAGEMENT.
2. QUICK CONNECT FUNCTION:
  - A. WITH SLIDER IN THE DISENGAGED POSITION, SLIDE THE CABLED CONNECTOR ONTO THE JACK RECEPTACLE, OVER THE JACK THREADS BY PUSHING ON THE BACK OF THE KNURLED NUT.
  - B. ENGAGE THE SLIDER WHILE MAINTAINING LIGHT FORWARD PRESSURE ON THE NUT. THIS ACTION IS DONE BY SLIPPING YOUR FINGERS FROM THE NUT TO THE SLIDER IN ONE MOTION.
  - C. ONCE THE SLIDER IS ENGAGED THE KNURLED NUT CAN BE TURNED 1 TURN OR LESS TO OBTAIN FULL MATING ENGAGEMENT PERFORMANCE.
  - D. DISENGAGE THE CONNECTOR BY FIRST LOOSENING THE COUPLING NUT A PARTIAL TURN. THEN DISENGAGE THE SLIDER AND REMOVE THE CONNECTOR.

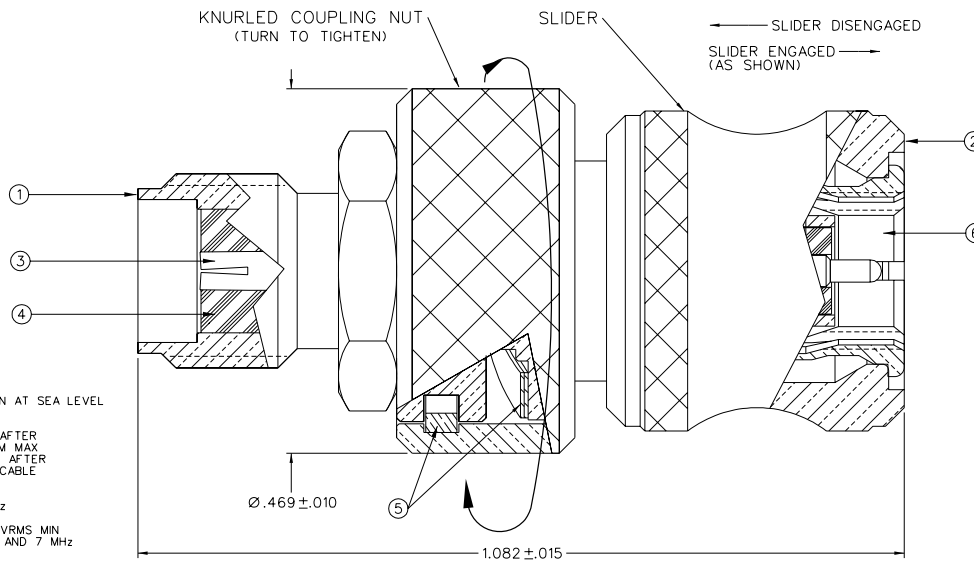

**NOTES:**

1. SPECIFICATIONS:
  - IMPEDANCE: 50 OHMS
  - FREQUENCY RANGE: 0-18 GHZ
  - VSWR: 1.05+.005 F MAX (F IN GHZ)
  - WORKING VOLTAGE: 500 VRMS MAX AT SEA LEVEL
  - DIELECTRIC WITHSTANDING VOLTAGE: 1500 VRMS MIN AT SEA LEVEL
  - INSULATION RESISTANCE: 5000 MEGOHM MIN
  - CONTACT RESISTANCE:
    - CENTER CONTACT - INITIAL 4.0 MILLIOHM MAX, AFTER ENVIRONMENTAL 6.0 MILLIOHM MAX
    - OUTER CONDUCTOR - INITIAL 2.0 MILLIOHM MAX, AFTER ENVIRONMENTAL NOT APPLICABLE
  - BRAID TO BODY - NOT APPLICABLE
  - CORONA LEVEL: 375 VOLTS MIN AT 70,000 FEET
  - INSERTION LOSS: .06V/F MAX (F IN GHZ) AT 6 GHZ
  - RF LEAKAGE: -90 DB MIN AT 2.5 GHZ
  - RF HIGH POTENTIAL WITHSTANDING VOLTAGE: 1000 VRMS MIN AT 4 AND 7 MHz

**MECHANICAL:**

- ENGAGE/DISENGAGE TORQUE: 2 INCH-POUNDS MAX
- MATING TORQUE: 7-10 INCH POUNDS
- COUPLING PROOF TORQUE: 15 INCH-POUNDS MIN
- COUPLING NUT RETENTION: 60 LBS MIN
- CONTACT RETENTION: 6 LBS MIN AXIAL FORCE
- CABLE ACCEPTABILITY: NOT APPLICABLE
- CABLE HEX CRIMP SIZE: NOT APPLICABLE
- CABLE RETENTION: NOT APPLICABLE
- DURABILITY: 1000 CYCLES MIN

**ENVIRONMENTAL:**

- (MEETS OR EXCEEDS THE APPLICABLE PARAGRAPH OF MIL-A-55339)
- THERMAL SHOCK: MIL-STD-202, METHOD 107, CONDITION B
- OPERATING TEMPERATURE: -65 DEG C TO 165 DEG C
- CORROSION: MIL-STD-202, METHOD 101, CONDITION B
- SHOCK: MIL-STD-202, METHOD 213, CONDITION I
- VIBRATION: MIL-STD-202, METHOD 204, CONDITION D
- MOISTURE RESISTANCE: MIL-STD-202, METHOD 106

CUSTOMER DRAWING

THIS DRAWING TO BE INTERPRETED PER ASME Y 14.5M - 1994

"μ STATION"

COMPANY CONFIDENTIAL

TOLERANCE UNLESS OTHERWISE SPECIFIED	DRAWN BY T.A.Kari	DATE 9-16-03	Connectivity Solutions P.O. Box 1732 Waseca, MN 56093 1-800-247-8256
DECIMALS    mm	CHECKED BY	DATE	
.XXX ± .003			TITLE ADAPTER, SMA, IN SERIES JACK TO QUICK CONNECT PLUG
MATL	APPROVED BY T.A.Kari	DATE 5-18-04	SHEET 2 OF 2
FINISH	RELEASE DATE U/M    INCH	5-18-04 SCALE 10:1	DRAWING NO. C - 142-1901-821/830