

■ Features :

- Universal AC input / Full range
- Protections: Short circuit / Overload / Over voltage
- Cooling by free air convection
- 100% full load burn-in test
- Fixed switching frequency at 56KHz
- 2 years warranty



SPECIFICATION

MODEL	S-25-5	S-25-12	S-25-15	S-25-24	
OUTPUT	DC VOLTAGE	5V	12V	15V	24V
	RATED CURRENT	5A	2.1A	1.7A	1.1A
	CURRENT RANGE	0 ~ 5A	0 ~ 2.1A	0 ~ 1.7A	0 ~ 1.1A
	RATED POWER	25W	25.2W	25.5W	26.4W
	RIPPLE & NOISE (max.) Note.2	50mVp-p	100mVp-p	100mVp-p	100mVp-p
	VOLTAGE ADJ. RANGE	4.75 ~ 5.5V	10.8 ~ 13.2V	13.5 ~ 16.5V	21.6 ~ 26.4V
	VOLTAGE TOLERANCE Note.3	±2.0%	±1.0%	±1.0%	±1.0%
	LINE REGULATION	±0.5%	±0.5%	±0.5%	±0.5%
	LOAD REGULATION	±1.0%	±0.5%	±0.5%	±0.5%
SETUP, RISE TIME	300ms, 50ms/230VAC 800ms, 50ms/115VAC at full load				
HOLD UP TIME (Typ.)	90ms/230VAC 12ms/115VAC at full load				
INPUT	VOLTAGE RANGE	85 ~ 264VAC 120 ~ 370VDC			
	FREQUENCY RANGE	47 ~ 63Hz			
	EFFICIENCY(Typ.)	72%/115VAC	76%/115VAC	77%/115VAC	80%/115VAC
	AC CURRENT (Typ.)	0.6A/115VAC 0.35A/230VAC			
	INRUSH CURRENT (Typ.)	COLD START 13A/115VAC 25A/230VAC			
	LEAKAGE CURRENT	<0.75mA / 240VAC			
PROTECTION	OVERLOAD	105 ~ 150% rated output power Protection type : Hiccup mode, recovers automatically after fault condition is removed.			
	OVER VOLTAGE	5.75V ~ 6.75V	13.8V ~ 16.2V	17.25V ~ 20.25V	27.6V ~ 32.4V
		Protection type : Hiccup mode, recovers automatically after fault condition is removed.			
ENVIRONMENT	WORKING TEMP.	-10 ~ +60°C (Refer to output load derating curve)			
	WORKING HUMIDITY	20 ~ 90% RH non-condensing			
	STORAGE TEMP., HUMIDITY	-20 ~ +85°C, 10 ~ 95% RH			
	TEMP. COEFFICIENT	±0.03%/°C (0 ~ 50°C)			
	VIBRATION	10 ~ 500Hz, 2G 10min./1cycle, period for 60min. each along X, Y, Z axes			
SAFETY & EMC (Note 4)	SAFETY STANDARDS	UL1012, TUV EN60950-1 approved			
	WITHSTAND VOLTAGE	I/P-O/P:3KVAC	I/P-FG:1.5KVAC	O/P-FG:0.5KVAC	
	ISOLATION RESISTANCE	I/P-O/P, I/P-FG, O/P-FG:100M Ohms / 500VDC / 25°C / 70% RH			
	EMI CONDUCTION & RADIATION	Compliance to EN55022 (CISPR22) Class B			
	HARMONIC CURRENT	Compliance to EN61000-3-2,-3			
OTHERS	EMS IMMUNITY	Compliance to EN61000-4-2,3,4,5; ENV50204, EN55024, light industry level, criteria A			
	MTBF	330.8K hrs min. MIL-HDBK-217F (25°C)			
NOTE	DIMENSION	99*97*36mm (L*W*H)			
	PACKING	0.39Kg; 45pcs/18Kg/0.9CUFT			
<p>1. All parameters NOT specially mentioned are measured at 230VAC input, rated load and 25°C of ambient temperature. 2. Ripple & noise are measured at 20MHz of bandwidth by using a 12" twisted pair-wire terminated with a 0.1uf & 47uf parallel capacitor. 3. Tolerance : includes set up tolerance, line regulation and load regulation. 4. The power supply is considered a component which will be installed into a final equipment. The final equipment must be re-confirmed that it still meets EMC directives. For guidance on how to perform these EMC tests, please refer to "EMI testing of component power supplies." (as available on http://www.meanwell.com)</p>					

Mechanical Specification

Case No. 905 Unit:mm

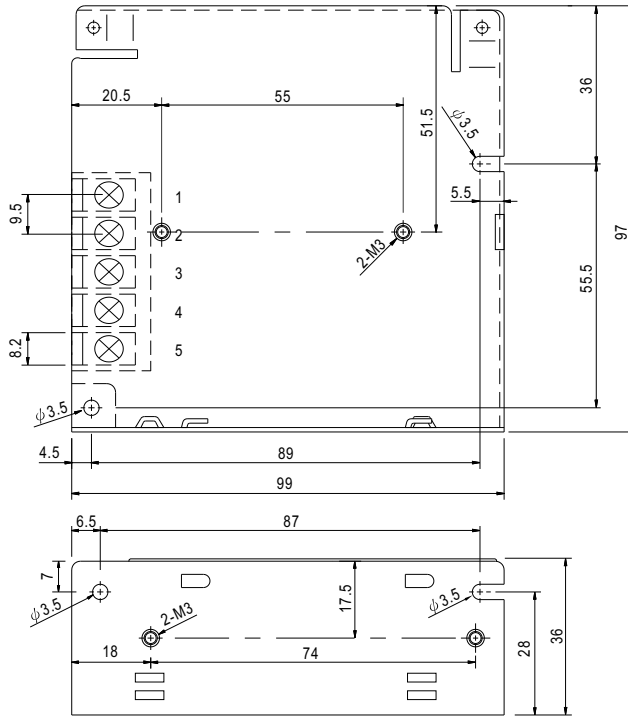

Terminal Pin No. Assignment

Pin No.	Assignment	Pin No.	Assignment
1	DC OUTPUT -V	4	AC/L
2	DC OUTPUT +V	5	AC/N
3	FG \perp		

Block Diagram

fosc : 56KHz

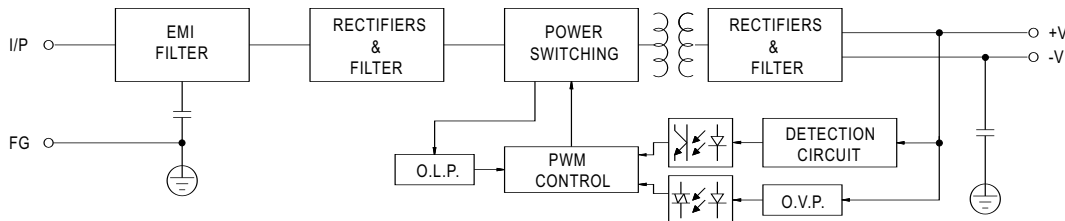

Derating Curve

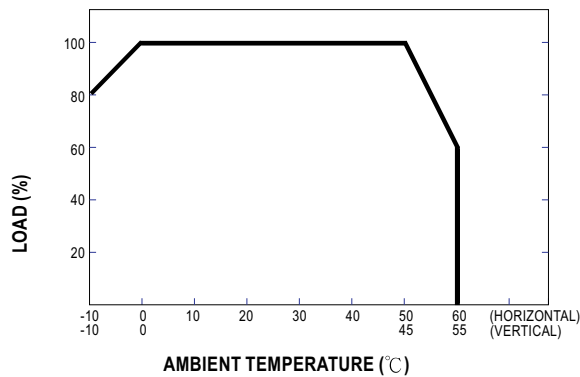

Static Characteristics (24V)

