

STEP-PS/ 1AC/24DC/1.75

Order No.: 2868648



<http://eshop.phoenixcontact.de/phoenix/treeViewClick.do?UID=2868648>

DIN rail power supply unit 24 V DC/1.75 A, primary switched-mode, 1-phase



Commercial data	
GTIN (EAN)	4 046356 172844
sales group	H011
Pack	1 pcs.
Customs tariff	85044082
Catalog page information	Page 602 (IF-2011)

Product notes

WEEE/RoHS-compliant since: 06/25/2007



<http://www.download.phoenixcontact.com>
 Please note that the data given here has been taken from the online catalog. For comprehensive information and data, please refer to the user documentation. The General Terms and Conditions of Use apply to Internet downloads.

Product description

STEP POWER power supply units – for building automation

The new STEP POWER generation of compact power supply units is particularly suitable for installation distributors and flat control panels thanks to its design. The power supply units are available with 24 V DC output voltage in various performance classes and widths and with the special voltages 5, 12, 15 and 48 V DC. Their high degree of efficiency and the low standby losses make for high power efficiency.

Technical data

Input data

Nominal input voltage	100 V AC ... 240 V AC
AC input voltage range	85 V AC ... 264 V AC
DC input voltage range	95 V DC ... 250 V DC
AC frequency range	45 Hz ... 65 Hz
DC frequency range	0 Hz
Current consumption	Approx. 0.6 A (120 V AC) Approx. 0.3 A (230 V AC)
Inrush surge current	< 15 A (typical)
Power failure bypass	> 25 ms (120 V AC) > 150 ms (230 V AC)
Input fuse	3.15 A (slow-blow, internal)
Permissible backup fuse	B6 B10 B16
Type of protection	Transient surge protection
Protective circuit/component	Varistor

Output data

Nominal output voltage	24 V DC \pm 1%
Setting range of the output voltage	22.5 V DC ... 29.5 V DC (> 24 V constant capacity)
Output current	1.75 A (-25°C ... 55°C) 1.9 A (-25 °C ... 40 °C permanent) 3.75 A (maximum output current)
Derating	55 °C ... 70 °C (2.5%/K)
Connection in parallel	Yes, for redundancy and increased capacity
Connection in series	Yes
Control deviation	< 1 % (change in load, static 10% ... 90%) < 2 % (change in load, dynamic 10% ... 90%) < 0.1 % (change in input voltage \pm 10%)
Residual ripple	< 60 mV _{PP} (20 MHz)
Peak switching voltages nominal load	< 40 mV _{PP} (20 MHz)
Maximum power dissipation idling	< 0.7 W
Power loss nominal load max.	5 W

General data

Width	54 mm
Height	90 mm
Depth	61 mm
Net weight	0.2 kg
Operating voltage display	Green LED
Efficiency	> 89 % (for 230 V AC and nominal values)
Insulation voltage input/output	4 kV AC (type test) 2 kV AC (routine test)
Degree of protection	IP20
Protection class	II
MTBF (IEC 61709, SN 29500)	> 500000 h (IEC 61709)
Ambient temperature (operation)	-25 °C ... 70 °C (> 55° C derating)
Ambient temperature (storage/transport)	-40 °C ... 85 °C
Max. permissible relative humidity (operation)	≤ 95 % (at 25 °C, no condensation)
Mounting position	horizontal DIN rail NS 35, EN 60715
Assembly instructions	Can be aligned: horizontal 0 cm, vertical 3 cm
Electromagnetic compatibility	Conformance with EMC Directive 2004/108/EC
Noise immunity	EN 61000-6-2:2005
Low Voltage Directive	Conformance with LV directive 2006/95/EC
Standard – Electrical equipment of machines	EN 60204
Standard - Safety of transformers	IEC 61558-2-17
Standard - Electrical safety	IEC 60950-1/VDE 0805 (SELV)
Shipbuilding approval	Germanischer Lloyd (EMC 1), ABS, NK
Standard – Electronic equipment for use in electrical power installations and their assembly into electrical power installations	EN 50178/VDE 0160 (PELV)
Standard – Safety extra-low voltage	IEC 60950-1 (SELV) and EN 60204 (PELV)
Standard - Safe isolation	DIN VDE 0100-410 DIN VDE 0106-1010
Standard – Protection against electric shock	DIN 57100-410
Standard – Protection against shock currents, basic requirements for protective separation in electrical equipment	DIN VDE 0106-101
Standard – Limitation of mains harmonic currents	EN 61000-3-2
Certificate	CB Scheme

UL approvals	UL/C-UL listed UL 508
	UL/C-UL Recognized UL 60950
	NEC Class 2 as per UL 1310
	UL/C-UL Listed ANSI/ISA-12.12.01 Class I, Division 2, Groups A, B, C, D

Connection data, input

Connection method	Screw connection
Conductor cross section solid min.	0.2 mm ²
Conductor cross section solid max.	2.5 mm ²
Conductor cross section stranded min.	0.2 mm ²
Conductor cross section stranded max.	2.5 mm ²
Conductor cross section AWG/kcmil min.	24
Conductor cross section AWG/kcmil max	12
Stripping length	6.5 mm
Screw thread	M3

Connection data, output

Connection method	Screw connection
Conductor cross section solid min.	0.2 mm ²
Conductor cross section solid max.	2.5 mm ²
Conductor cross section stranded min.	0.2 mm ²
Conductor cross section stranded max.	2.5 mm ²
Conductor cross section AWG/kcmil min.	24
Conductor cross section AWG/kcmil max	12
Stripping length	6.5 mm

Signaling

Output name	LED status indicator
Status display	"DC OK" LED green
Note on status display	U _{OUT} > 21.5 V: LED lights up

Certificates / Approvals



Certification

CB, CUL, CUL Listed, GL, NK, UL, UL Listed

Certification Ex:

CUL-EX LIS, UL-EX LIS

Diagrams/Drawings

Block diagram

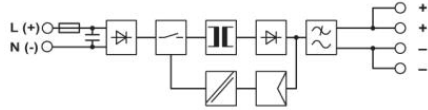

Dimensioned drawing

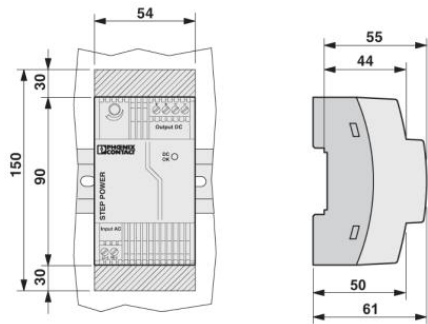

Schematic diagram

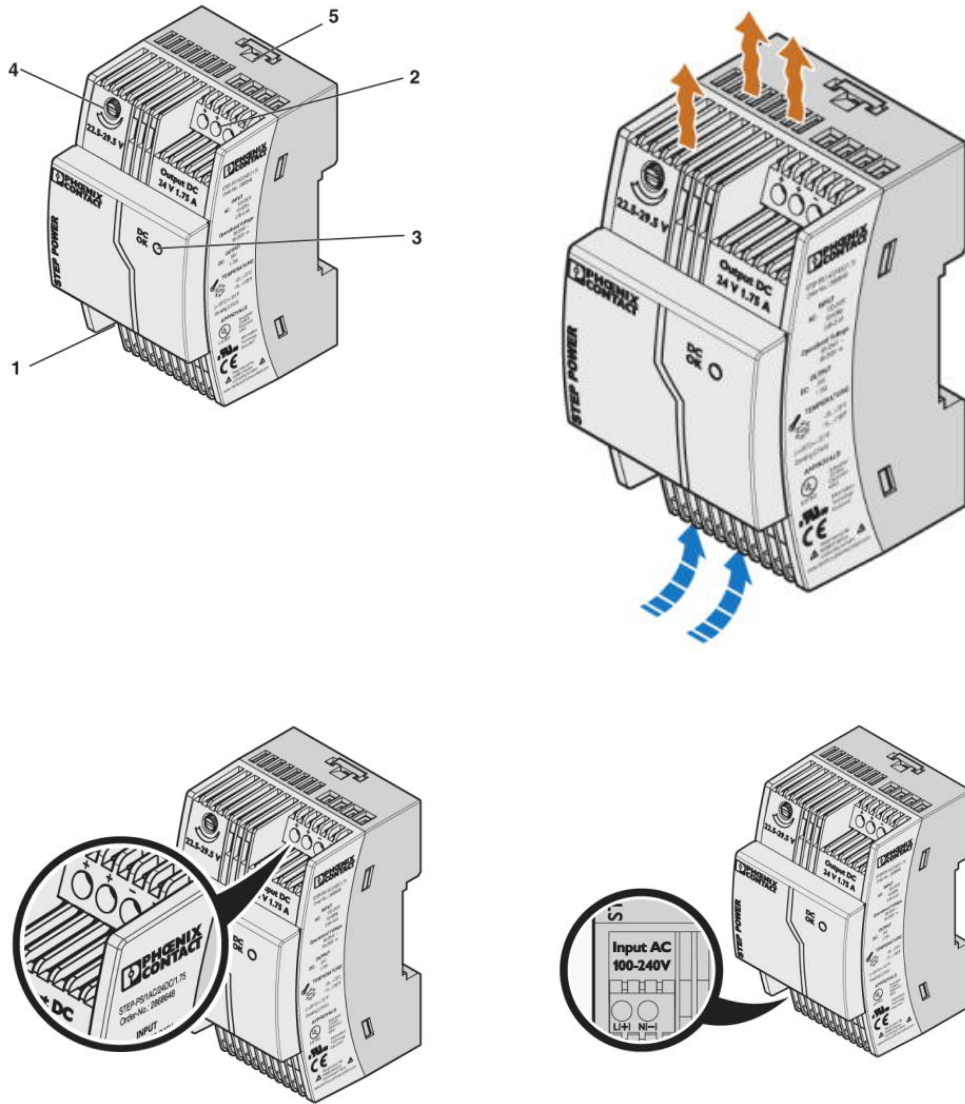

Address

PHOENIX CONTACT Inc., USA
586 Fulling Mill Road
Middletown, PA 17057, USA
Phone (800) 888-7388
Fax (717) 944-1625
<http://www.phoenixcon.com>



© 2011 Phoenix Contact
Technical modifications reserved;