

PS001W SERIES

LED PUSH BUTTON SWITCH



Feature -

- LED illumination , Two color available
- Snap in Panel Mount installation
- Single pole / Single throw , Momentary

Applications -

- Automotive Industry
- Office Appliance
- Communication Equipments, Racing Helmet

► SPECIFICATIONS

SWITCH SPECIFICATIONS	
POLE - POSITION	Momentary Type , SPST with LED
CONTACT RATING	30 V DC , 0.1 A
CONTACT RESISTANCE	50 mΩ max. 1.5 V DC ; 100 mA , by Method of Voltage DROP
INSULATION RESISTANCE	100 MΩ min. 500 V DC
DIELECTRIC STRENGTH	Breakdown is not Allowable ; 500 V AC for 1 Minute
OPERATING FORCE	400 ± 100 gf
OPERATING LIFE	50,000 cycles
OPERATING TEMPERATURE RANGE	-40°C ~ 85°C
TOTAL TRAVEL	1.5 ± 0.3 mm

LED SPECIFICATIONS							
ATTENTION LEDs are Electrostatic Sensitive devices	Unit	Value / LED Color					
		Blue	Green	Red	White	Yellow	
FORWARD CURRENT	If	mA	30	30	30	30	
REVERSE VOLTAGE	Vr	V	5.0	5.0	5.0	5.0	
REVERSE CURRENT	Ir	μA	50	10	10	10	
FORWARD VOLTAGE@20mA	Vf	V	@4mA 2.5-3.5	1.7-2.6	2.0-2.5	3.3-3.8	2.2-2.7
LUMINOUS INTENSITY@20mA	Iv	mcd	@4mA 160	65-120	100	145	200

■ Physical and electrical information of LED will be provided upon customer's request on switches .

► HOW TO ORDER

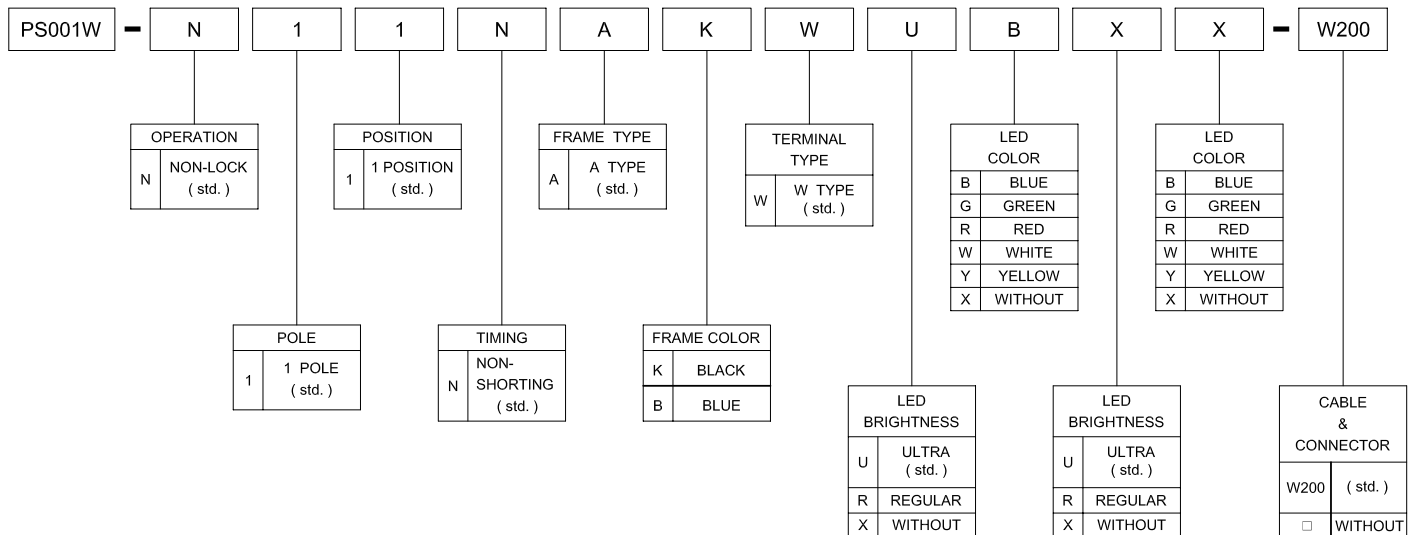

PS001W SERIES

LED PUSH BUTTON SWITCH

► DIMENSION

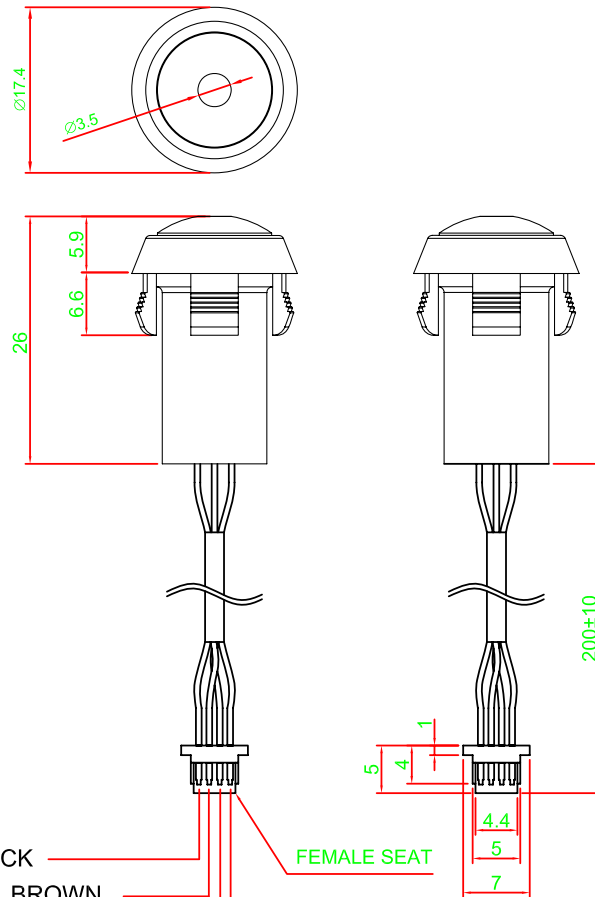

- 1 (VBAT) BLACK
- 2 (P SWITCH) BROWN
- 3 (LED +) RED
- 4 (LED -) ORANGE

► PS001W-N11NAKWUBXX-W200

► LED CIRCUIT DIAGRAM

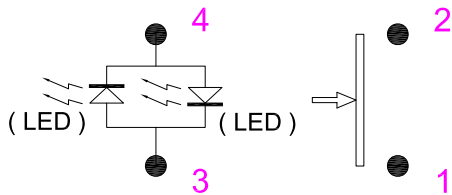

► MATERIAL

- COVER - PA + GF
- ACTUATOR - PC
- BASE FRAME - PA + GF
- TERMINAL - BRASS GOLD FLASH

► PANEL CUT OUT

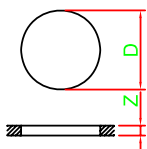

Z	D
1.0 ~ 2.0	15.2 ~ 15.4
2.0 ~ 2.5	15.4 ~ 15.8
2.5 ~ 3.0	15.8 ~ 16.0

► UNIT WEIGHT

- PS001 - 3.9 ± 0.1 g / pcs