

110/316-P-Series



The 110/316-P-Series pushbutton switches are heavy duty, AC/DC rated and suitable as foot-switches. These switches are available with alternate or momentary action. This series is equipped with a quick-make, quick-break contact mechanism which is both non-teasable and self-cleaning. Typical actuation force ranges from 6-8 lbs.

Specifications

- Certifications*: UL, CSA
- Dielectric Strength: 1,000V (minimum)
- Insulation Resistance: 100 Megohms (minimum)
- Base Material: Phenolic
- Actuator Material: Brass/Nickel Plate
- Bushing Material: Brass/Nickel Plate

* Due to ongoing technological advances, consult factory for certification specifics.

Dimensional Specifications: in. [mm]

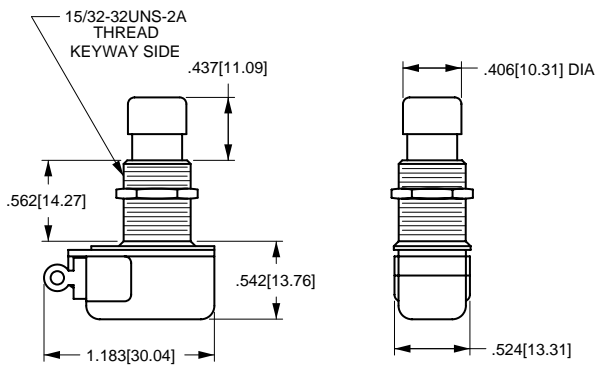

NOTE:
KEYWAY
.072[1.82] X .038[.965] DP

 .093[2.36] DIA .293[7.44]	 .075[1.90] DIA .250[6.35] .351[8.92]	 .070[1.77] DIA .174[4.42] .120[3.05]
SOLDER LUG	.250 TAB (Q.C.) (SPST only)	SOLDER LUG (bottom)
TERMINAL TYPE		
 .270[6.85] .080[2.03] DIA	 #6-32NC-2 THREAD .270[6.86] .415[10.54]	 6.000[152.4] .500[12.70]
END TERMINAL	SCREW (ASSEMBLED) (SPST ONLY)	INTEGRATED WIRE LEAD (no exposed conductors)
 .500[12.70] DIA MOUNTING HOLE		 .062[1.57] .500[12.70] DIA WITH KEYWAY

110

-

P

MAINTAINED	(ON) MOMENTARY NORMALLY OPEN	(OFF) MOMENTARY NORMALLY CLOSED	TERMINAL	CIRCUIT & POLES	RATING
110-P 110-BP 110-SP 111-16-P	110-PM-OFF 110-PBM-OFF 110-SPM-OFF 111-PM-OFF	110-PM-ON 110-PBM-ON 110-SPM-ON 111-PM-ON	SOLDER LUG-END SOLDER LUG-BTM SCREW TERM. WIRE LEAD	SP-ST	3A 250V 6A 125V
160H-P 160H-BP 160H-SP 160H-AP	NONE	NONE	SOLDER LUG SOLDER LUG-BTM SCREW TERM. WIRE LEAD	SP-ST	5A 250V 10A 125V 1/4HP 125V
216-PP 216-PPA	216-PM-OFF 216-PAM-OFF	216-PM-ON 216-PAM-ON	SOLDER LUG WIRE LEAD	DP-ST	1A 250V 3A 125V
112-P 112-PA	ON-(ON) 112-PM 112-PAM		SOLDER LUG WIRE LEAD	SP-DT	
316-PP 316-PPA	ON-(ON) 316-PM 316-PAM		SOLDER LUG WIRE LEAD	DP-DT DP-DT	
516-PP 516-PPA	516-PM 516-PAM		SOLDER LUG WIRE LEAD	2 CIRCUIT 1 ON - 1 OFF	

NOTES:
Shading indicates standard configurations.
Tab terminals available on all above SPST switches. Add suffix /TABS to end of part number. (ex.) 110-PM-OFF/TABS