

# 172DIP PCB Mount Miniature Reed Relay/SPDT and DPDT 0.25 Amp Rated

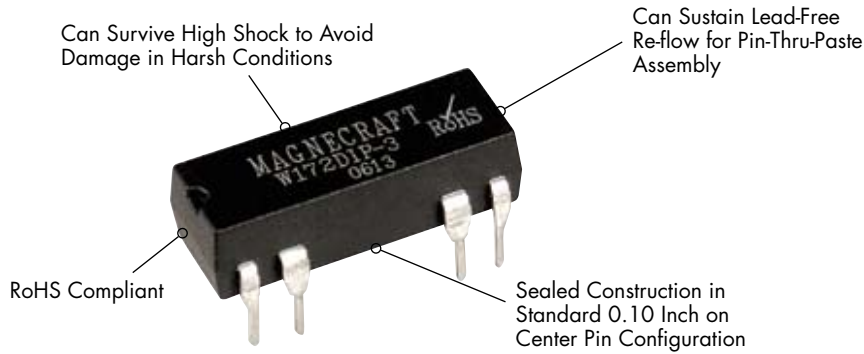

## General Specifications

Contact Characteristics		Units	172DIP SPDT	172DIP DPDT
Number and type of Contacts			SPDT	DPDT
Contact materials			Rhodium	Rhodium
Current rating		A	0.25	0.25
Switching voltage		~ V	60	60
Minimum Switching Requirement		≡ V	100	100
Minimum		mA	10	10
Coil Characteristics				
Voltage Range		≡ V	5...24	5...24
Operating Range		% of Nominal	80% to 110%	80% to 110%
Average consumption		≡ W	0.29	0.29
Drop-out voltage threshold		≡ V	10%	10%
Performance Characteristics				
Electrical Life		Operations @ Rated Current (Resistive)	50,000,000	50,000,000
Mechanical Life		Unpowered	100,000,000	100,000,000
Operating time (response time)		ms	1	1
Rated insulation voltage		Between coil and contact	~ V	~ V
Dielectric strength		Between poles	~ V	~ V
rms voltage		Between contacts	~ V	~ V
Environment				
Ambient air temperature		Storage	°C	°C
around the device		Operation	-40...+85	-40...+85
Vibration resistance		Operational	°C	°C
Shock resistance			-40...+55	-40...+55
Weight			g-n	g-n
			20, 10-200 Hz	20, 10-200 Hz
			50	50
			grams	grams
			1	1

172DIP SPDT

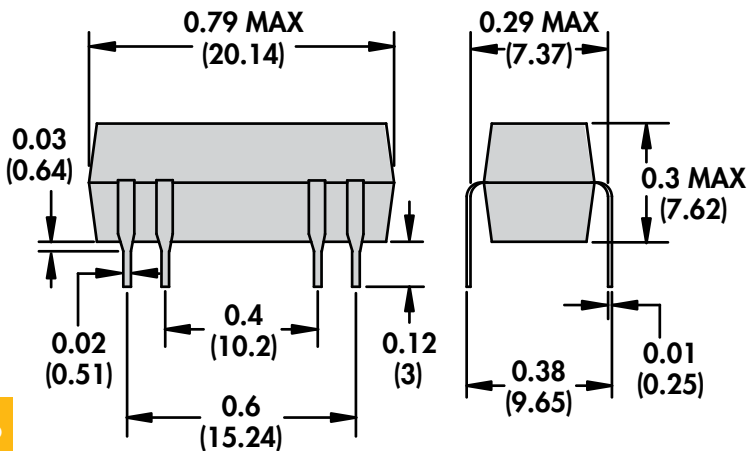

172DIP DPDT

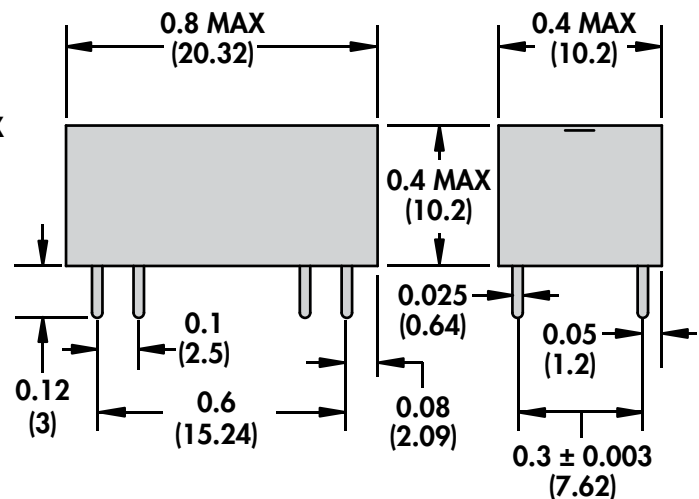

WHEN SPACING DIP RELAYS, THE RELAYS REQUIRE 1/2 INCH SPACING FROM THE SIDE OF THE ADJACENT RELAYS



**Standard Part Numbers**

**BOLD-FACED PART NUMBERS ARE NORMALLY STOCKED**

Nominal Input Voltage	Nominal Coil Resistance ( $\Omega$ )	Part Number	Contact Configuration	Figure
5 VDC	200 $\Omega$	<b>W172DIP-1</b>	SPDT	A
12 VDC	1000 $\Omega$	<b>W172DIP-3</b>	SPDT	A
24 VDC	2200 $\Omega$	<b>W172DIP-4</b>	SPDT	A
5 VDC	200 $\Omega$	<b>W172DIP-5</b>	SPDT w/ Clamping Diode	B
12 VDC	1000 $\Omega$	<b>W172DIP-7</b>	SPDT w/ Clamping Diode	B
24 VDC	2200 $\Omega$	<b>W172DIP-8</b>	SPDT w/ Clamping Diode	B
5 VDC	200 $\Omega$	<b>W172DIP-31</b>	SPDT	C
12 VDC	1000 $\Omega$	<b>W172DIP-33</b>	SPDT	C
24 VDC	2200 $\Omega$	W172DIP-34	SPDT	C
5 VDC	200 $\Omega$	<b>W172DIP-35</b>	SPDT w/ Clamping Diode	D
12 VDC	1000 $\Omega$	<b>W172DIP-37</b>	SPDT w/ Clamping Diode	D
24 VDC	2200 $\Omega$	W172DIP-38	SPDT w/ Clamping Diode	D
5 VDC	200 $\Omega$	<b>W172DIP-141</b>	SPDT	E
12 VDC	1000 $\Omega$	<b>W172DIP-145</b>	SPDT	E
24 VDC	3200 $\Omega$	<b>W172DIP-146</b>	SPDT	E
5 VDC	200 $\Omega$	<b>W172DIP-147</b>	SPDT w/ Clamping Diode	F
12 VDC	1000 $\Omega$	<b>W172DIP-149</b>	SPDT w/ Clamping Diode	F
24 VDC	3200 $\Omega$	<b>W172DIP-150</b>	SPDT w/ Clamping Diode	F
5 VDC	46 $\Omega$	<b>W172DIP-17</b>	DPDT	G
12 VDC	266 $\Omega$	<b>W172DIP-19</b>	DPDT	G
24 VDC	1066 $\Omega$	<b>W172DIP-20</b>	DPDT	G
5 VDC	46 $\Omega$	<b>W172DIP-21</b>	DPDT w/ Clamping Diode	H
12 VDC	266 $\Omega$	<b>W172DIP-23</b>	DPDT w/ Clamping Diode	H
24 VDC	1066 $\Omega$	<b>W172DIP-24</b>	DPDT w/ Clamping Diode	H

**WIRING DIAGRAMS TOP VIEW**

CIRCUIT BOARD PIN SPACING  
VIEWED FROM COMPONENT SIDE  
(TOP VIEW)

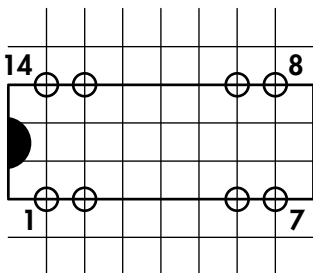

0.1 IN GRID  
(2.54 MM)

