

Power PCB Relay G8PT

- Up to 30 A switching capacity in compact package.
- Available with quick-connect contact terminals for easy load connecting with either QC or PCB coil terminals.
- UL Class F coil insulation standard even in optional sealed construction.
- Complies with UL 873 and UL 508 column A insulation resistance spacings up to 300 V.
- Minimum 6 kV Impulse Surge Withstand.
- Ideal for home and industrial appliances, HVAC and many other applications.
- UL/CSA and VDE approvals.

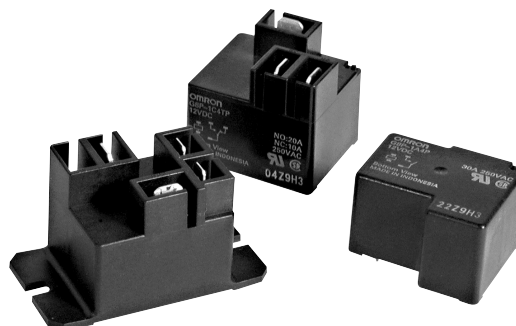

Ordering Information

To Order: Select the part number and add the desired coil voltage rating, (e.g., G8P-1A4P-DC12).

Mounting type	Contact form	Construction	Model
PCB	SPST-NO	Open frame	G8P-1AP
		Sealed with ventable nib*	G8P-1A4P
	SPDT	Open frame	G8P-1CP
		Sealed with ventable nib*	G8P-1C4P
PCB & Quick Connect load terminals	SPST-NO	Open frame	G8P-1ATP
		Sealed with ventable nib*	G8P-1A4TP
	SPDT	Open frame	G8P-1CTP
		Sealed with ventable nib*	G8P-1C4TP
Flange mount Quick Connect terminals	SPST-NO	Vented	G8P-1A2T-F
	SPDT	Vented	G8P-1C2T-F

Note: Load terminals are .250" Quick Connect. Coil terminals on Flange Mount versions are .187" Quick Connect.

* Sealed and vented optional.

Specifications

Contact Data

Type	SPST-NO	SPDT
Rated load	30 A 250 VAC, 20 A 28 VDC	20/10 A* at 250 VAC, 20/20 A at 28 VDC
Contact material	AgSnIn standard (other alloys available)	
Carry current	30 A max.	20/10 A*
Max. operating voltage	250 VAC, 28 VDC	
Max. operating current	AC 30 A, DC 20 A	AC 20/10 A, DC 20/10 A*
Max. switching capacity	7,500 VA, 560 W	5,000/2,500 VA, 560/280 W*
Min. permissible load	500 mA @ 5 VDC (AgSnIn), 100 mA @ 5 VDC (optional alloy)	

* NO contact/NC contact

Coil Data

Rated voltage (VDC)	Rated current (mA)	Coil resistance (Ω)	Pick-up voltage	Dropout voltage	Maximum voltage	Power consumption (mW)
			% of rated voltage			
5	185	27	75% max.	10% min.	120% max.	Approx. 900
9	93	97				
12	77	155				
24	36	660				
48	19	2,480				
110	9	12,400				

Note: The rated current and coil resistance are measured at a coil temperature of 23°C (73°F) with tolerances of $\pm 10\%$.

Characteristics

Contact resistance	100 m Ω max. (measured with 5 VDC, 1 A)	
Operate time	15 ms. max.	
Release time	10 ms. max.	
Insulation resistance	10 M Ω min. (at 500 VDC)	
Dielectric strength	2,500 VAC, 50/60 Hz for 1 minute (coil to contacts), 1,500 VAC, 50/60 Hz for 1 minute (between contacts)	
Impulse surge withstand	6,000 V between coil to contacts (1.2 μ s/50 μ s & 100 kHz ring wave per IEC 1000-4-12)	
Vibration	Mechanical durability	10 to 55 Hz, 1.65 mm (0.06 in) double amplitude for 2 hours
	Malfunction durability	10 to 55 Hz, 1.65 mm (0.06 in) double amplitude for 5 minutes
Shock	Mechanical durability	1,000 m/s ² (approx. 100 G)
	Malfunction durability	100 m/s ² (approx. 10 G)
Ambient temperature	-55° to 105°C (-67° to 221°F)	
Humidity	45% to 85% RH	
Service life	Mechanical	10 million operations minimum
	Electrical	100,000 operations at rated load (minimum)

Note: Data shown are of initial value. Operate and release times excluding bounce.

Characteristic Data

Maximum switching capacity
SPST-NO

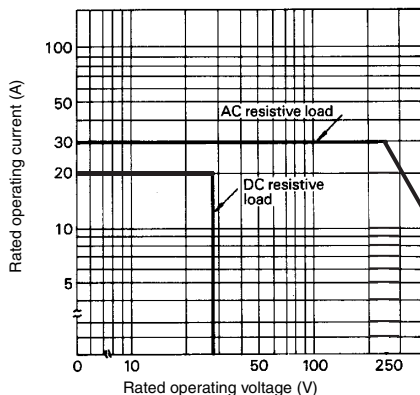

SPDT

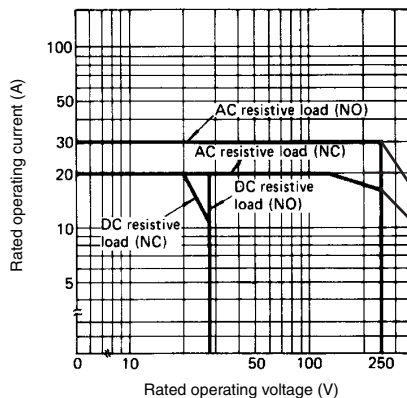

Characteristic Data

Electrical service life
SPST-NO

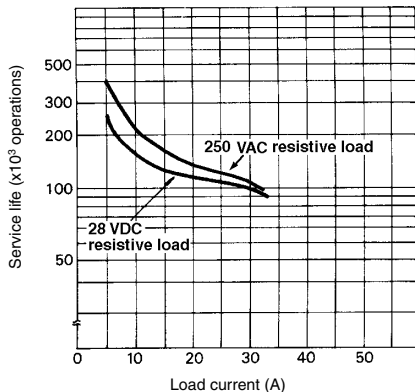

SPDT

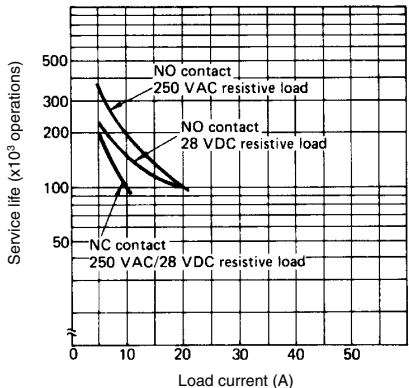

Dimensions

Unit: mm (inch)

Relays

Open frame, PCB terminals

Terminal arrangement/
Internal connections
(Bottom view)

Mounting holes
(Bottom view)

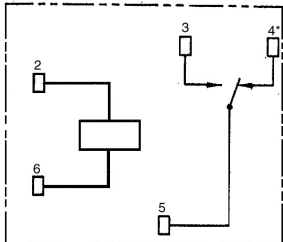
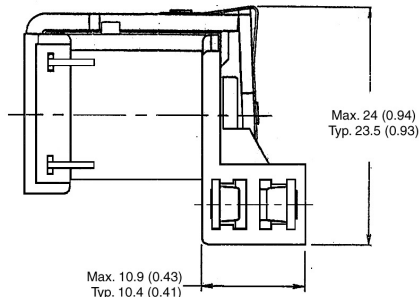

Note: Terminal #4 is omitted on SPST-NO version.

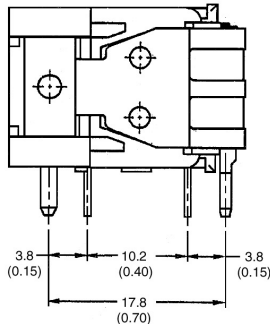
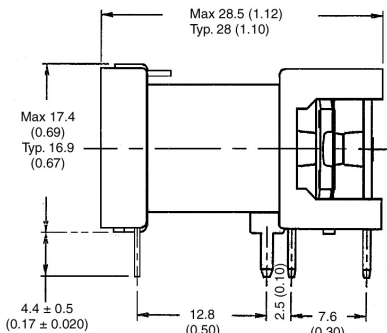
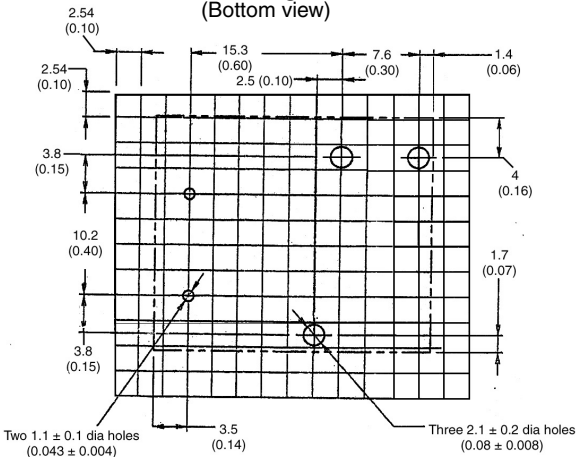

Unit: mm (inch)

Sealed/Ventable, PCB terminals

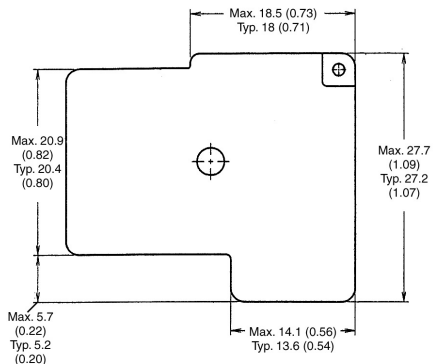

**Terminal arrangement/
Internal connections
(Bottom view)**

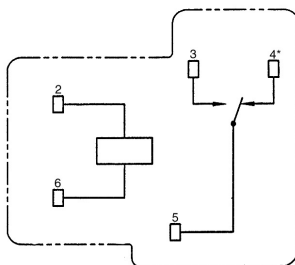

Note: Terminal #4 is omitted on SPST-NO version.

**Mounting holes
(Bottom view)**

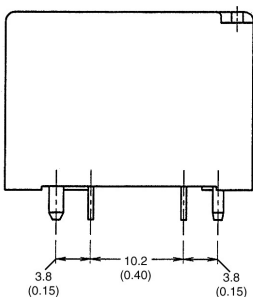
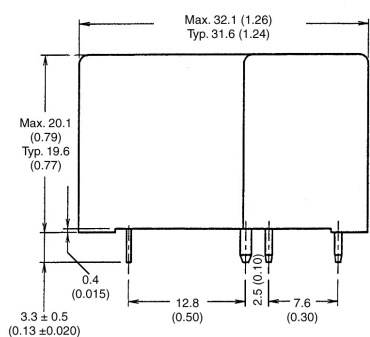
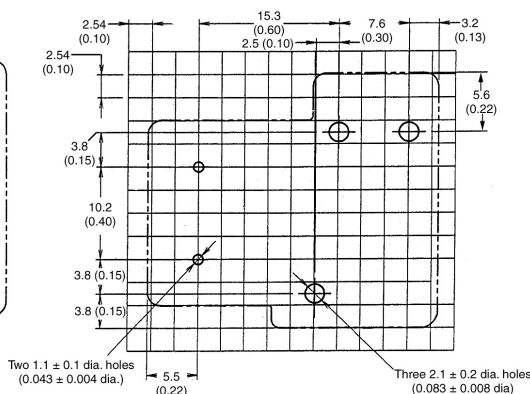

Pin Dimensions

large = 1.6 x 1.2; 1.2 x 0.8 x 3.3L
small = 0.6 x 0.5 x 3.3L

**Open frame, PCB with
Quick Connect terminals**

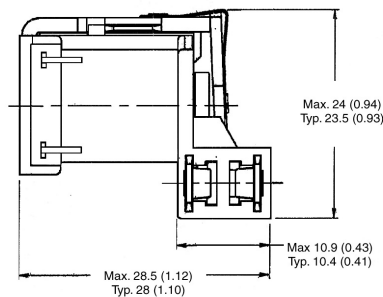

**Terminal arrangement/
Internal connections
(Bottom view)**

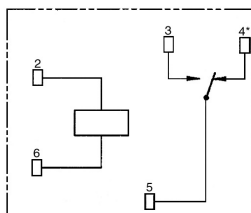

Note: Terminal #4 is omitted on SPST-NO version.

**Mounting holes
(Bottom view)**

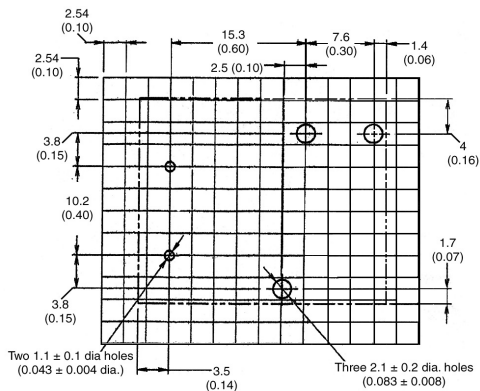

Pin Dimensions

large = 1.6 x 1.2; 1.2 x 0.8 x 3.3L
small = 0.6 x 0.5 x 3.3L

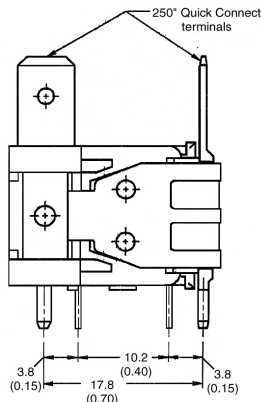
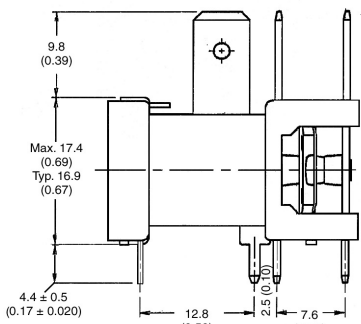

Unit: mm (inch)

Sealed/Ventable, PCB with Quick Connect terminals

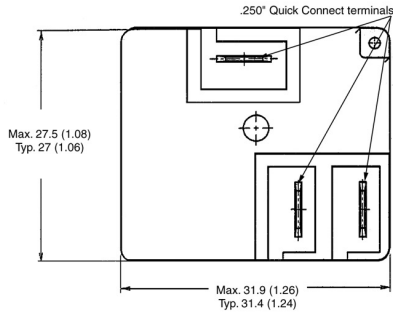

**Terminal arrangement/
Internal connections
(Bottom view)**

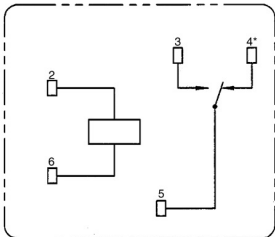

Note: Terminal #4 is omitted on SPST-NO version.

**Mounting holes
(Bottom view)**

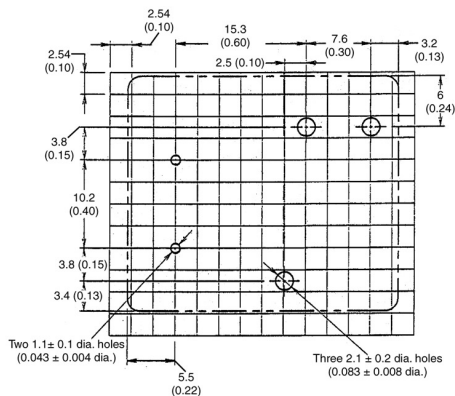

Pin Dimensions
large = 1.6 x 1.2; 1.2 x 0.8 x 3.3L
small = 0.6 x 0.5 x 3.3L

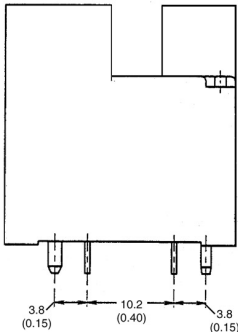
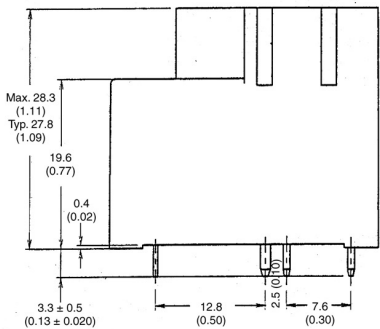

Flange mount

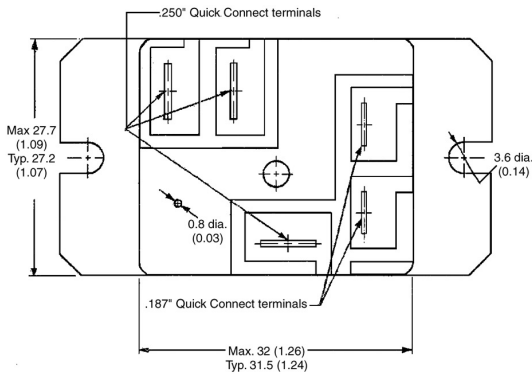

**Terminal arrangement/
Internal connections
(Bottom view)**

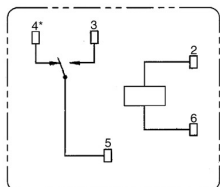

Note: Terminal #4 is omitted on SPST-NO version.

**Mounting holes
(Bottom view)**

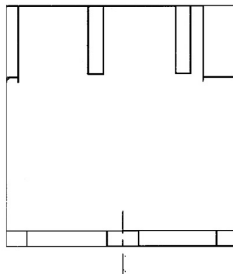
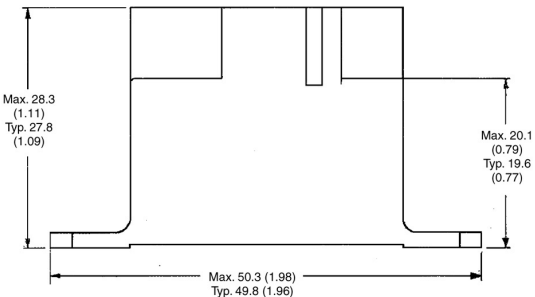
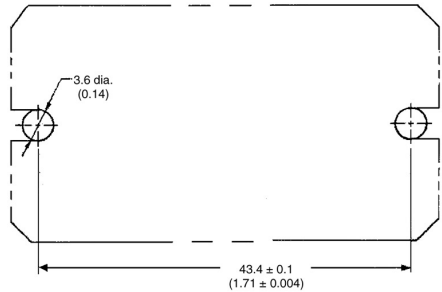

Note: Allow air circulation within the sealed type G8PT by removing the ventilation nib from the cover after soldering and cleaning is complete.

■ Approvals

UL Recognized (File No. E42643), CSA Certified (File No. LR34815)

Contact form	Coil ratings	Contact ratings
SPST-NO	5 to 110 VDC	30 A, 277 VAC (G.P./RES), 100,000 cycles 30 A, 240 VAC, 70° C, 100,000 cycles (G.P./Res.) 20 A, 28 VDC (Res.) 20 A, 240 VAC, 105° C, 100,000 cycles (Res.) 25 A, 240 AC, 105° C, 6,000 cycles (Res.) 1 HP, 125-250 VAC 2 HP, 250 VAC A300 Pilot Duty 12 FLA, 72LRA, 250 VAC, 100,000 cycles 20 FLA, 96 LRA, 125 VAC, 100,000 cycles 5 A, 250 VAC (Tungsten) 20 A, 120-277 VAC (Ballast) TV-5
SPDT	5 to 110 VDC	NO/NC 30 A/30 A, 277 VAC (G.P./Res.), 100,000 cycles (N.O.) and 50,000 cycles (N.C.) 20 A/15 A, 120-240 VAC, 105° C, 100,000 cycles (Res.) 20 A/10 A, 120-240 VAC, 70° C, 100,000 cycles (G.P./Res.) 20 A/10 A, 28 VDC (Res.) 25 A, 240 AC, 105° C, 6,000 cycles (Res.) 1/2 HP/1/2 HP, 125 VAC, 100,000 cycles 2 HP/ 1/2 HP, 250 VAC 1 HP/ 1/4 HP, 125 VAC B150 Pilot Duty 5 A/ 3 A, 250 VAC (Tungsten) 6 A/ 3 A, 277 VAC (Ballast) TV-5 (N.O.)

VDE recognized type (Licence No. 40004714)

- Note:**
1. The rated values approved by each of the safety standards (e.g., UL, CSA) may be different from the performance characteristics individually defined in this catalog.
 2. For information on additional ratings not included in this catalog, contact your local Omron Representative.
 3. In the interest of product improvement, specifications are subject to change.
 4. Please contact Omron for details regarding VDE approvals.
 5. Meets requirements of pollution degree 2 with Material II & III.