

THIS DOCUMENT IS THE PROPERTY OF
KEYSTONE ELECTRONICS CORP. AND
SHALL NOT BE REPRODUCED, DISTRIBUTED
OR USED AS A BASIS FOR MANUFACTURE
WITHOUT PRIOR WRITTEN PERMISSION
FROM KEYSTONE ELECTRONICS CORP.

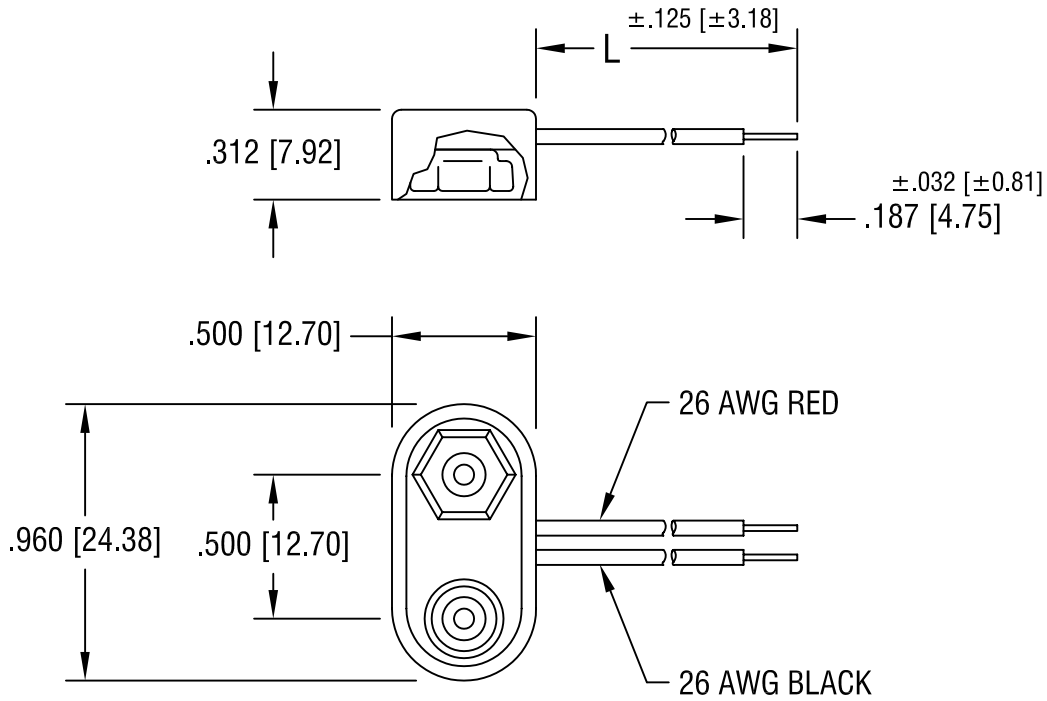

NOTES:

1. MAT'L -

WIRE: 26 AWG, 1007 UL/CSA APPROVED
.052 [1.32] O.D. PVC INSULATION.
RED WIRE CONNECTED TO FEMALE CONTACT;
BLACK WIRE TO MALE CONTACT.

PART NO.	'L' DIM.
81-4	4.000 [101.60]
81-6	6.000 [152.40]
81-8	8.000 [203.20]

2. BASE:

MAT'L - ABS
CONTACT:
MAT'L - BRASS
FINISH - NICKEL PLATE
EYELET:
MAT'L - BRASS

KEYSTONE ELECTRONICS CORP.			
ASTORIA, N.Y. 11105-2017			
PART NAME			
SHIELDED 9 VOLT 'T' TYPE BATTERY STRAP			
MATERIAL			
AS NOTED			
FINISH		DRN BY	DATE
AS NOTED		BOONE	1.7.97
		APP'D	SCALE
			1.5X
TOLERANCES	INCH [MM]	CODE	DWG NO.
DECIMAL	± .010 [± 0.25]	C/M	81-
ANGULAR	± 1°		
UNLESS OTHERWISE SPECIFIED			

DATE	DESCRIPTION	REV.
11.10.03	CHANGE AS PER ECN 03-083	B
4.1.98	CHANGE AS PER ECR 98-020	A