



Designers' Choice

STEEL BATTERY HOLDERS

RUGGED STEEL BATTERY HOLDERS

An established design that has gained wide acceptance for commercial and military applications. Batteries are held under constant spring tension assuring low contact resistance. Retainer clips are available to lock batteries in place and prevent shifting or loosening of the batteries. Recommended for use where shock or severe vibration is encountered. Special fabrication for more than four batteries or variations from standard stock parts can be assembled to meet your requirements.

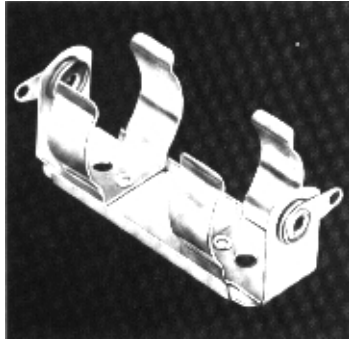

- Ideal for NiCd, Alkaline, NiMH, Carbon, Zinc and Lithium Cells
- Corrosion Resistant, Nickel Plate
- Brass Contacts, Nickel Plate
- Moisture Proof Resin Impregnated, Fibre Insulating Washers

1100 SERIES

(GROUNDED ONE SIDE)



DIMPLE CONTACT

INSULATED CONTACT

2100 SERIES

(FULLY INSULATED)



INSULATED CONTACTS

INSULATOR TUBES SUPPLIED FOR 2-3-4 CELLS END TO END

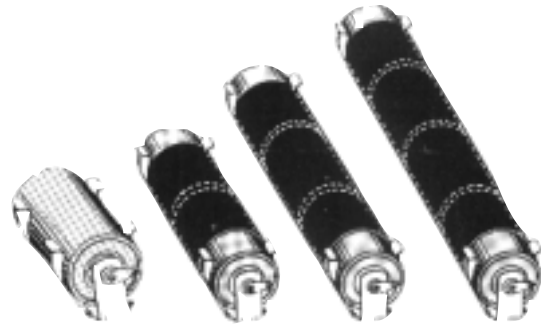

FIG. 19

FIG. 20

FIG. 21

FIG. 22

PHENOLIC BASE

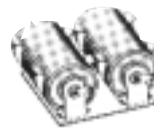

FIG. 23

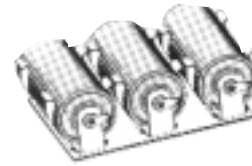

FIG. 24

PHENOLIC BASE



FIG. 25

MODIFICATIONS AVAILABLE

Use our engineering services for your custom battery holders or modifications to our standard products.

JUMPERS

Jumpers permit cost saving and eliminates wiring.

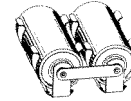

SPECIAL LUGS

Printed Circuit, Solderless or Quick-Fit Lugs available for your special connection requirements.

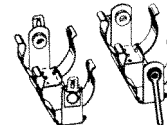

MULTIPLE UNITS

Jumpers, special lugs and polarized contacts available for custom applications.

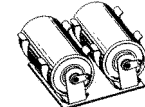

POLARIZED CONTACTS

Assure proper battery insertion and correct polarity.



INSULATED POLARIZING WASHERS

Prevents improper connection of battery which may cause damage to electronic equipment. Washers hold securely when snapped over eyelets. Used on our standardized battery holders. For AA, C & D cells.

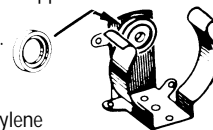

MATERIAL: Molded Polyethylene

CAT. NO. 59 (RED) CAT. NO. 60 (BLACK)

1100 SERIES		2100 SERIES		BATTERY CROSS REFERENCE			
ONE CONTACT INSULATED	ALL CONTACTS INSULATED	FIG. NO.	HOLDS NO. OF CELLS	All Batteries listed within boxes are in the same size group			
CAT. NO.	CAT. NO.			EVEREADY	DURACELL	RAY-O-VAC	NEDA
"AA" CELL HOLDERS				(BATTERY SIZE $\frac{531}{565}$ O.D. \times $\frac{1.906}{1.988}$ H)			
1139	2139	19	1	E9, EV15, EN91, CH15, E133, E133N, E177, 505, 523, 1015, 1215	ZM9, RM12R, NC15AA, M15F, M15AA, TR133R, TR177, M505, MN1500, PC1500	5AA, 615, 815, 7AA	15, 15A, 15C, 15D, 15F, 15M, 15NC, 221, 1101M, 1113M, 1306AP, 1306M, 1314M, 1606M
—	2140*	23	2				
—	2171*	24	3				
—	2182*	25	4				
1189	2189	20	2				
1191	2191	21	3				
1194	2194	22	4				
"C" CELL HOLDERS				(BATTERY SIZE $\frac{.875}{1.125}$ O.D. \times $\frac{1.875}{1.969}$ H)			
1173	2173	19	1	CH35, E93, 935, 1235, EV35, EN93	M14F, M14HD, NC14C, TR286, MN1400, PC1400	1C, 614, 814	14A, 14C, 14D, 14F, 14NC, 1600M
—	2174*	23	2				
—	2187*	24	3				
—	2188*	25	4				
1185	2185	20	2				
1195	2195	21	3				
1198	2198	22	4				
"D" CELL HOLDERS				(BATTERY SIZE $\frac{1.187}{1.375}$ O.D. \times $\frac{2.312}{2.412}$ H)			
1175	2175	19	1	CH50, E95, 950, 1250, EV50, EN95	M13F, NC13D, S42, M13HD, TR289, MN1300, PC1300	2D, 6D, 613, 813	13A, 13C, 13D, 13F, 13NC, 1115M, 1810M
—	2176*	23	2				
—	2190*	24	3				
—	2192*	25	4				
1186	2186	20	2				
1199	2199	21	3				
1162	2162	22	4				

*Clips mounted on Phenolic 1/16" thick