

THIS DOCUMENT IS THE PROPERTY OF
KEYSTONE ELECTRONICS CORP. AND
SHALL NOT BE REPRODUCED, DISTRIBUTED
OR USED AS A BASIS FOR MANUFACTURE
WITHOUT PRIOR WRITTEN PERMISSION
FROM KEYSTONE ELECTRONICS CORP.

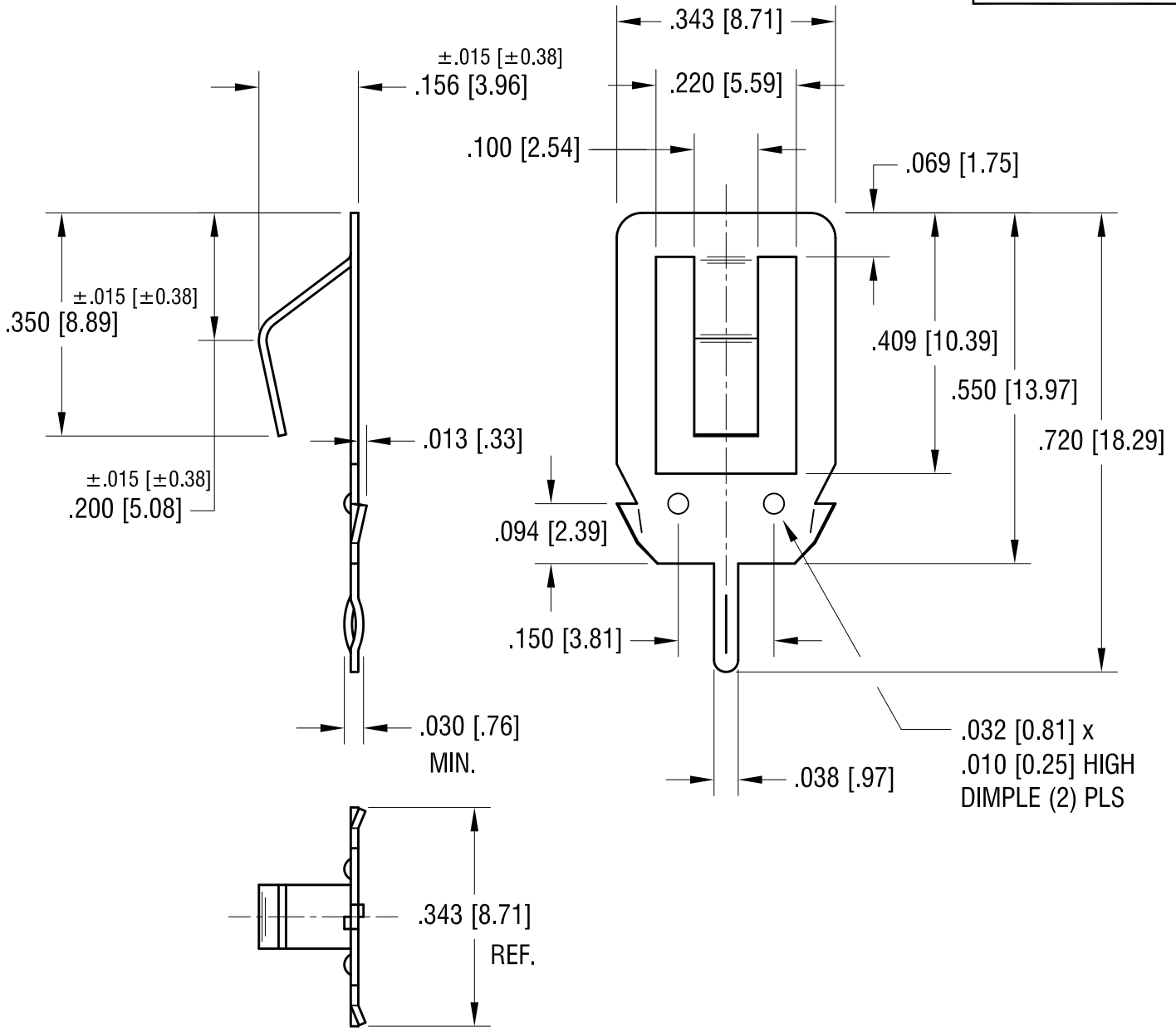

KEYSTONE ELECTRONICS CORP.

ASTORIA, N.Y. 11105-2017

PART NAME

PC BATTERY CONTACT

MATERIAL

.012 [.30] TH'K STAINLESS STEEL, FULL HARD

FINISH

TIN NICKEL PLATE

DRN BY

BOONE

DATE

5.17.93

APP'D

SCALE

4X

TOLERANCES

INCH [MM]

DECIMAL

$\pm .005$ [± 0.15]

ANGULAR

$\pm 1^\circ$

UNLESS OTHERWISE SPECIFIED

CODE

C

DWG NO.

108-2

8.27.09

CHANGE AS PER ECN 09-121

F

8.27.04

CHANGE AS PER ECN 04-076

E

DATE

DESCRIPTION

REV.