

THIS DOCUMENT IS THE PROPERTY OF KEYSTONE ELECTRONICS CORP. AND SHALL NOT BE REPRODUCED, DISTRIBUTED OR USED AS A BASIS FOR MANUFACTURE WITHOUT PRIOR WRITTEN PERMISSION FROM KEYSTONE ELECTRONICS CORP.

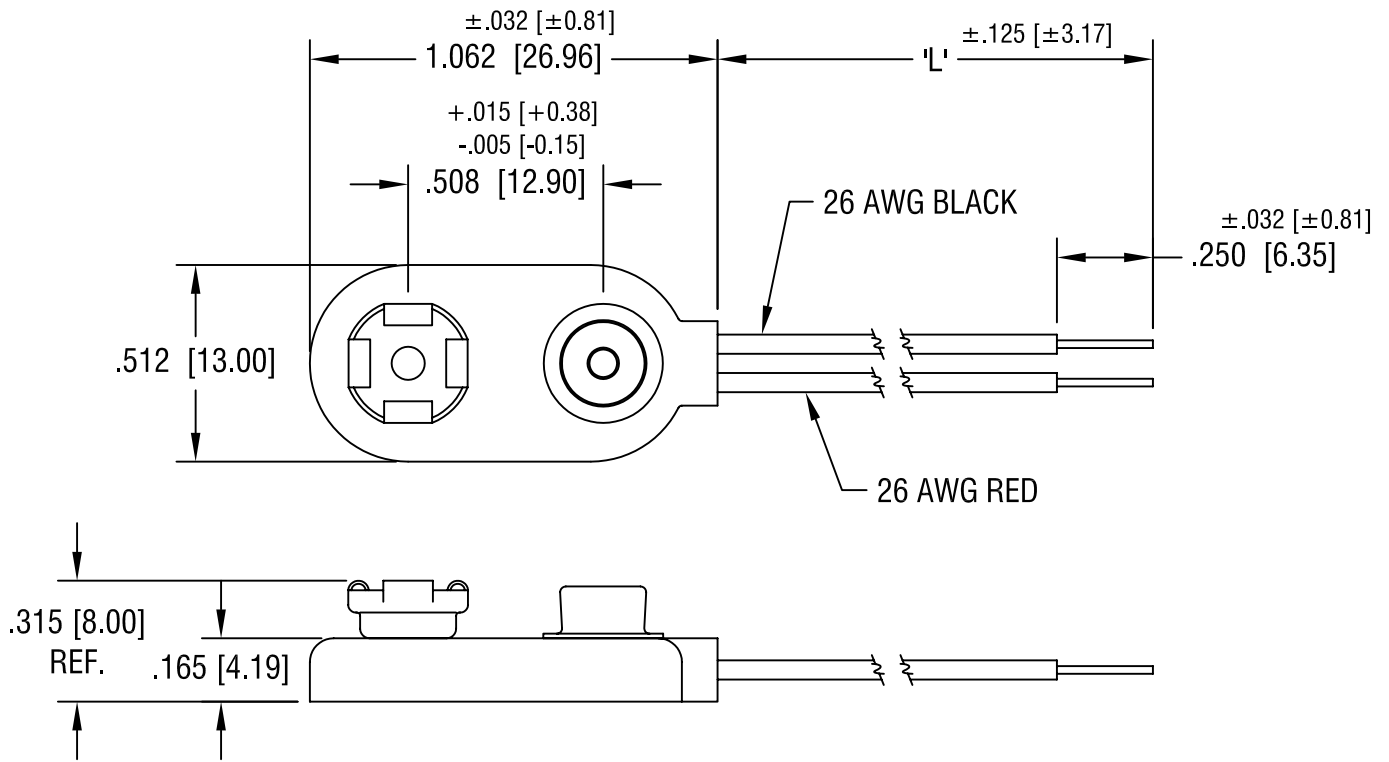

**NOTE:**

- 1. MAT'L - WIRE: 26 AWG, 1007 UL/CSA APPROVED
- CONTACTS: PHOSPHOR BRONZE, NICKEL PLATE
- BODY: MOLDED POLYETHYLENE
- RED WIRE CONNECTED TO FEMALE CONTACT;
- BLACK WIRE CONNECTED TO MALE CONTACT.

PART NO.	'L' DIM.
2238	4.000 [101.60]
2239	6.000 [152.40]
2240	8.000 [203.20]

**KEYSTONE ELECTRONICS CORP.**  
ASTORIA, N.Y. 11105-2017

PART NAME <b>PREMIUM '9' VOLT 'I' STYLE BATTERY STRAP</b>			
MATERIAL <b>AS NOTED</b>			
FINISH <b>AS NOTED</b>		DRN BY <b>BOONE</b>	DATE <b>8.8.95</b>
		APP'D	SCALE <b>2X</b>
TOLERANCES INCH [MM] DECIMAL <b>± .020 [± 0.50]</b> ANGULAR <b>± 1°</b> UNLESS OTHERWISE SPECIFIED	CODE <b>C/M</b>	DWG NO. <b>2238-2240</b>	

3.10.05	CHANGE AS PER ECN 05-016	A
DATE	DESCRIPTION	REV.